

I

Name _____

Roll No. _____ Year 20 _____ 20 _____

Exam Seat No. _____

ELECTRICAL GROUP | SEMESTER - III | DIPLOMA IN ENGINEERING AND TECHNOLOGY

A LABORATORY MANUAL FOR ELECTRICAL AND ELECTRONIC MEASUREMENTS (22325)

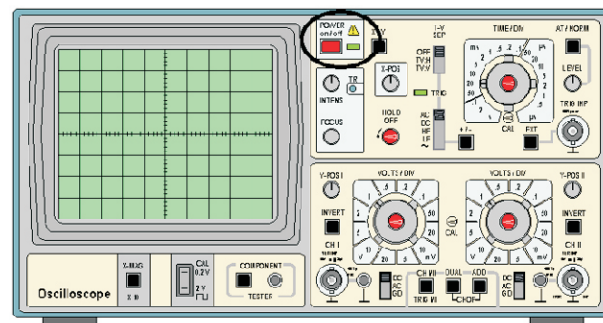
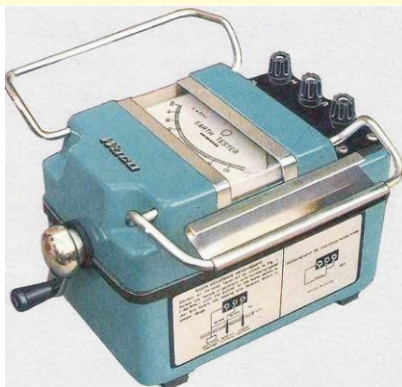

MAHARASHTRA STATE BOARD OF TECHNICAL EDUCATION, MUMBAI
(Autonomous) (ISO 9001 : 2015) (ISO / IEC 27001 : 2013)

VISION

To ensure that the Diploma level Technical Education constantly matches the latest requirements of technology and industry and includes the all-round personal development of students including social concerns and to become globally competitive, technology led organization.

MISSION

To provide high quality technical and managerial manpower, information and consultancy services to the industry and community to enable the industry and community to face the changing technological and environmental challenges.

QUALITY POLICY

We, at MSBTE are committed to offer the best in class academic services to the students and institutes to enhance the delight of industry and society. This will be achieved through continual improvement in management practices adopted in the process of curriculum design, development, implementation, evaluation and monitoring system along with adequate faculty development programmes.

CORE VALUES

MSBTE believes in the followings:

- Education industry produces live products.
- Market requirements do not wait for curriculum changes.
- Question paper is the reflector of academic standards of educational organization.
- Well designed curriculum needs effective implementation too.
- Competency based curriculum is the backbone of need based program.
- Technical skills do need support of life skills.
- Best teachers are the national assets.
- Effective teaching learning process is impossible without learning resources.

A Laboratory Manual
for
Electrical and Electronic
Measurement

(22325)

Semester-III

(EE/EP/EU)

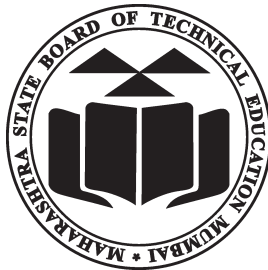

Maharashtra State
Board of Technical Education, Mumbai
(Autonomous) (ISO:9001:2015) (ISO/IEC 27001:2013)

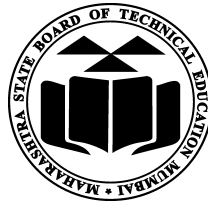

Maharashtra State Board of Technical Education,
(Autonomous) (ISO:9001 : 2015) (ISO/IEC 27001 : 2013)
4th Floor, Government Polytechnic Building, 49, Kherwadi,
Bandra (East), Mumbai - 400051.

(Printed on June, 2018)



**MAHARASHTRA STATE
BOARD OF TECHNICAL EDUCATION**

Certificate

This is to certify that Mr. / Ms.
Roll No., of Third Semester of Diploma in
..... of Institute,
.....
(Code:) has completed the term work satisfactorily in course
Electrical and Electronic Measurement (22325) for the academic year
20..... to 20..... as prescribed in the curriculum.

Place:

Enrollment No:.....

Date:

Exam. Seat No:

Subject Teacher

Head of the Department

Principal



Preface

The primary focus of any engineering laboratory/ field work in the technical education system is to develop the much needed industry relevant competencies and skills. With this in view, MSBTE embarked on this innovative ‘I’ Scheme curricula for engineering diploma programmes with outcome-base education as the focus and accordingly, relatively large amount of time is allotted for the practical work. This displays the great importance of laboratory work making each teacher; instructor and student to realize that every minute of the laboratory time need to be effectively utilized to develop these outcomes, rather than doing other mundane activities. Therefore, for the successful implementation of this outcome-based curriculum, every practical has been designed to serve as a ‘*vehicle*’ to develop this industry identified competency in every student. The practical skills are difficult to develop through ‘chalk and duster’ activity in the classroom situation. Accordingly, the ‘I’ scheme laboratory manual development team designed the practicals to *focus* on the *outcomes*, rather than the traditional age old practice of conducting practicals to ‘verify the theory’ (which may become a byproduct along the way).

This laboratory manual is designed to help all stakeholders, especially the students, teachers and instructors to develop in the student the pre-determined outcomes. It is expected from each student that at least a day in advance, they have to thoroughly read through the concerned practical procedure that they will do the next day and understand the minimum theoretical background associated with the practical. Every practical in this manual begins by identifying the competency, industry relevant skills, course outcomes and practical outcomes which serve as a key focal point for doing the practical. The students will then become aware about the skills they will achieve through procedure shown there and necessary precautions to be taken, which will help them to apply in solving real-world problems in their professional life.

This manual also provides guidelines to teachers and instructors to effectively facilitate student-centered lab activities through each practical exercise by arranging and managing necessary resources in order that the students follow the procedures and precautions systematically ensuring the achievement of outcomes in the students.

The electrical diploma holder has to work in industry as technical person in middle level management. He has to work as production, maintenance, testing engineer in various industries like power generation, transmission, distribution, traction etc. and has to deal with different electrical measurement. While performing above task he has to measure different electrical and electronic parameters with testing, therefore he/she must require the skills for these measurements and broad idea of different meters and equipments.

Although best possible care has been taken to check for errors (if any) in this laboratory manual, perfection may elude us as this is the first edition of this manual. Any errors and suggestions for improvement are solicited and highly welcome

Programme Outcomes (POs) to be achieved through Practical of this Course:-

PO2.Discipline knowledge: Apply Electrical Engineering knowledge to solve broad based Electrical Engineering related problems.

PO3.Experiments and practice: Plan to perform experiments and practices to use the results to solve broad-based Electrical Engineering problems.

PO4.Engineering tools: Apply relevant Electrical technologies and tools with an understanding of the limitations.

Program Specific Outcomes (PSOs):-

PSO 1. Electrical Equipment: Maintain various types of rotating and static electrical equipment.

List of Industry Relevant Skills

The following industry relevant skills of the competency 'Use relevant measuring instrument in different electrical applications' are expected to be developed in you by undertaking the practicals of this practical manual.

1. Identify the measuring instruments.
2. Use various measuring instruments for specific application.
3. Troubleshoot the various measuring instruments.

Practical- Course Outcome matrix

Course Outcomes (COs):-						
a. Identify electrical measuring instrument. b. Use voltmeter and ammeter for electrical measurement. c. Use wattmeter for electrical power measurement. d. Use energy meter for electrical energy measurement. e. Use measuring instrument						
S. No.	Practical Outcome	CO a.	CO b.	CO c.	CO d.	CO e.
1.	Identify measuring instruments on the basis of symbols on dial, type, accuracy, class position and scale.	√	-	-	-	-
2.	Identify the components of PMMC and MI instruments.	√	-	-	-	-
3.	Troubleshoot PMMC and MI instruments.	√	√	√	-	√
4.	Measure AC and DC quantities in a working circuit.	√	√	√	-	√
5.	Extend range of ammeter and voltmeter by using (i) shunt and multiplier (ii) CT and PT.	√	√	-	-	√
6.	Use Clamp-on meter for measurement of AC/DC current, AC/DC voltage.	√	√	-	-	√
7.	Use electro-dynamic watt-meter for measurement of power in a single phase circuit	√	-	√	-	√
8.	Use single wattmeter for measurement of active and reactive power of three phase balanced load.	√	-	√	-	√
9.	Troubleshoot electrodynamic watt-meter for measurement of power in a single phase circuit	√	-	√	-	√
10.	Use two watt-meters for measuring active power of three-phase balanced load.	√	-	√	-	√
11.	Calibrate single phase electronic energy meter by direct loading.	√	-	-	√	√
12.	Troubleshoot single phase electronic energy meter.	√	-	-	√	√
13.	Use digital multi-meter for measurement of AC/DC current, AC/DC voltage.	√	√	-	-	√
14.	Use Kelvin's double bridge for measurement of low resistance.	√	-	-	-	√
15.	Use voltmeter and ammeter method for measurement of medium resistance.	√	√	-	-	√
16.	Use Megger for insulation resistance measurements.	√	-	-	-	√

17.	Use earth tester for measurement of earth resistance.	√	-	-	-	√
18.	Use CRO for the Measurement of supply frequency in single-phase circuit.	√	-	-	-	√
19.	Use Tri-vector meter for measuring kW, kVAr and kVA of a power line.	√	-	-	-	√

Guidelines to Teachers

1. Teacher need to ensure that a dated log book for the whole semester, apart from the laboratory manual is maintained by every student which s/he has to submit for assessment to the teacher in the next practical session.
2. There will be two sheets of blank pages after every practical for the student to report other matters (if any), which is not mentioned in the printed practicals.
3. For difficult practicals if required, teacher could provide the demonstration of the practical emphasizing of the skills which the student should achieve.
4. Teachers should give opportunity to students for hands-on after the demonstration.
5. Assess the skill achievement of the students and COs of each unit.
6. One or two questions ought to be added in each practical for different batches. For this teachers can maintain various practical related question bank for each course.
7. If some repetitive information like data sheet, use of software tools etc. has to be provided for effective attainment of practical outcomes, they can be incorporated in Appendix.
8. For effective implementation and attainment of practical outcomes, teacher ought to ensure that in the beginning itself of each practical, students must read through the complete write-up of that practical sheet.
9. During practical, ensure that each student gets chance and takes active part in taking observations/ readings and performing practical.
10. Teacher ought to assess the performance of students continuously according to the MSBTE guidelines

Instructions for Students

1. For incidental writing on the day of each practical session every student should maintain a dated log book for the whole semester, apart from this laboratory manual which s/he has to submit for assessment to the teacher in the next practical session.
2. For effective implementation and attainment of practical outcomes, in the beginning itself of each practical, students need to read through the complete write-up including the practical related questions and assessment scheme of that practical sheet.
3. Student ought to refer the data books, IS codes, Safety norms, Electricity act/rules, technical manuals, etc.
4. Student should not hesitate to ask any difficulties they face during the conduct of practicals.

Content Page

List of Practicals and Progressive Assessment Sheet

S. No	Practical Outcome	Page No.	Date of performance	Date of submission	Assessment marks(25)	Dated sign. of teacher	Remarks (if any)
1.	Identify measuring instruments on the basis of symbols on dial, type, accuracy, class position and scale.	1					
2.	Identify the components of PMMC and MI instruments.	8					
3.	Troubleshoot PMMC and MI instruments.	14					
4.	Measure AC and DC quantities in a working circuit.	19					
5.	Extend range of ammeter and voltmeter by using (i) shunt and multiplier (ii) CT and PT.	24					
6.	Use Clamp-on meter for measurement of AC/DC current, AC/DC voltage.	33					
7.	Use electro-dynamic watt-meter for measurement of power in a single phase circuit	41					
8.	Use single wattmeter for measurement of active and reactive power of three phase balanced load.	46					
9.	Troubleshoot electrodynamic watt-meter for measurement of power in a single phase circuit	53					
10.	Use two watt-meters for measuring active power of three-phase balanced load.	58					
11.	Calibrate single phase electronic energy meter by direct loading.	64					
12.	Troubleshoot single phase electronic energy meter.	70					

S. No	Practical Outcome	Page No.	Date of performance	Date of submission	Assessment marks(25)	Dated sign. of teacher	Remarks (if any)
13.	Use digital multi-meter for measurement of AC/DC current, AC/DC voltage.	74					
14.	Use Kelvin's double bridge for measurement of low resistance.	81					
15.	Use voltmeter and ammeter method for measurement of medium resistance.	86					
16.	Use Megger for insulation resistance measurements.	91					
17.	Use earth tester for measurement of earth resistance.	98					
18.	Use CRO for the Measurement of supply frequency in single-phase circuit.	103					
19.	Use Tri-vector meter for measuring kW, kVAr and kVA of a power line.	107					
Total							

Note: To be transferred to Proforma of CIAAN-2017.

Practical No. 1: Measuring instruments identification

I Practical Significance

In the industry Electrical Engineering diploma graduate are expected to identify various measuring instruments as per IS codes. Therefore this practical will help you to acquire necessary skills.

II Relevant Program Outcomes (POs)

- **Discipline knowledge:** Apply Electrical Engineering knowledge to solve broad based Electrical Engineering related problems.
- **Experiments and practice:** Plan to perform experiments and practices to use the results to solve broad-based Electrical Engineering problems.
- **Engineering tools:** Apply relevant Electrical technologies and tools with an Understanding of the limitations.

III Competency and Practical Skills

This practical is expected to develop the following skills for the industry-identified Competency: ‘Use relevant measuring instrument in different electrical Applications’

1. Identification of measuring instrument.

IV Relevant Course Outcome(s)

- a. Identify electrical measuring instrument.

V Practical Outcome

Identify measuring instruments on the basis of symbols on dial, type, accuracy, class position and scale.

VI Relevant Affective domain related Outcome(s)

- Follow safe practices.
- Practice good housekeeping.
- Maintain tools and measuring instruments.

VII Minimum Theoretical Background

I. S. 2032 - 1969 has standardized certain symbols for different types of analog instruments used for electrical measurement purpose. These symbols are printed on the dial of the instruments. Information about meter can be obtained from these symbols.

(The symbols and description in tabular form is given in Annexure- A)

VIII Practical set-up / Circuit diagram / Work Situation

Select various instruments from laboratory.

IX Resources Required

S. No.	Name of Resource	Suggested Broad Specification	Quantity
1	Ammeter	(0-10A), Moving coil meter/ Moving iron	1 each
2	Voltmeter	(0-300v), Moving coil meter/ Moving iron	1 each
3	Multimeter	Digital	1 each

X Precautions to be Followed

1. Chose the correct range of meter. (eg. For measuring single-phase supply voltage Correct range is 0-300 V)
2. Identify the correct instrument for AC/ DC measurement.
3. Use the instrument in the correct position as specified on dial.
4. Correct the zero error of the meter by adjusting zero adjustment screw.

XI Procedure

1. Select an ammeter of required range depending on the following :
 - Rating as indicated on dial
 - Type of supply
 - Type of instrument
 - Mounting method
 - Meter Symbols
2. Select voltmeter, wattmeter and follow the above procedure.

XII Resources Used (Student should write the resources required)

S. No	Name of Resource	Broad Specifications		Quantity	Remarks (If any)
		Make	Details		
1.					
2.					
3.					
4.					
5.					

XIII Actual Procedure Followed (use blank sheet provided if space not sufficient)

.....

XIV Observations and Calculations (use blank sheet provided if space not sufficient)

Sr. No.	Specification of meter	Symbol	Meaning of symbol	Type of instrument	Mounting Method	Remark
1						
2						
3						
4						
5						

XV Results

.....

XVI Interpretation of Results (Give meaning of the above obtained results)

.....
.....
.....

XVII Conclusions (Actions/decisions to be taken based on the interpretation of results).

.....
.....
.....

XVIII Practical Related Questions (Note:- Teacher should provide various questions related to practical- sample given)

1. Name the instrument, which can be used on both AC and DC supply.
2. Suggest class of instruments which are generally used on panel boards.
3. Draw the BIS symbols related to identification of instruments for the following items,

Sr. No.	Items	BIS Symbol
1	Direct and alternating current	
2	Testing potential 500 V	
3	Vertical using position	
4	Class 1.5 determined by the length of scale.	
5	Moving coil instrument	
6	Galvanometer	

(Space for answers)

.....
.....
.....
.....
.....
.....
.....
.....
.....
.....
.....

.....

.....

.....

.....

.....

.....

XIX References / Suggestions for further reading

1. Experiments in Basic Electrical Engineering S.K.Bhattacharya K.M.Rastogi ISBN: 978-81-224-1041-6 New Age International Publications
2. www.electrical4u.com
3. Electrical Measurements and Measuring Instruments U. A. Bakshi A. V. Bakshi K. A. Bakshi ISBN 9788184314380 First Edition – 2008 Technical Publications Pune

XX Suggested Assessment Scheme

Performance indicators		Weightage
Process related: 6 Marks		60%
1	Handling of the instruments	10 %
2	Identification of component/dial/scale	20 %
3	Measuring value using suitable instrument	20 %
4	Working in team	10 %
Product related: 4 Marks		40%
5	Writing result	10 %
6	Interpretation of result	05 %
7	Conclusions	05 %
8	Practical related questions	15 %
9	Submitting the journal in time	05%
Total (10 Marks)		100 %



Names of Student Team Members





1.
2.
3.







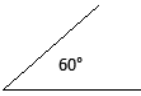



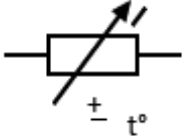

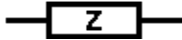

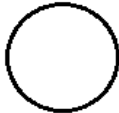

Marks Obtained			Dated signature of Teacher
Process Related(6)	Product Related(4)	Total (10)	

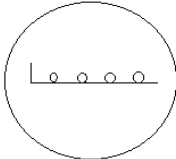



Annexure- A

Following table gives various symbols as per IS 2032 (Part X) -1969

A) Principal Units			
Kilo- Ampere	kA	Volt-Amp Reactive	VAR
Ampere	A	Milli- Ampere	mA
Volt	V	Hertz	Hz
Megawatt	MW	Ohm	Ω
Watt	W	Tesla	T
B) Type of supply for Which Apparatus is used			
Direct Current	—	D.C. & A.C.	~
Alternating Current	~	3 ϕ A.C.	~ ~ ~ ~
C) Direct Test Voltage			
Test voltage 500V		Test voltage above 500V (for e.g. 2kV)	
Apparatus not to subject for dielectric test			

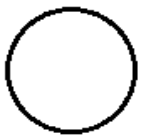
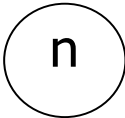
D) Reference position of Use			
Instrument to be used with the dial vertical		Instrument to be used with dial horizontal.	
Instrument to be used with the dial inclined (for e.g.60°) from the horizontal plane.		Resistance continuously variable.	

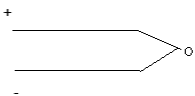
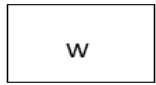
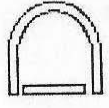
Resistance with moving-contact variable continuously.		Temperature dependent resistor	
Series inductor		Series impedance	
Electrostatic screening		Magnetic screening	
Earth terminal			
E) Indicating Instruments			
General Symbol-indicating instrument		Instrument with pointer indicator	
Instrument with digital indication		Voltmeter	
Wattmeter		Multimeter	
Frequency meter		Power factor meter	
VAR meter		Ohmmeter	

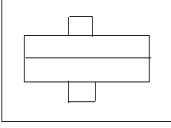
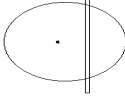
Thermometer, pyrometer		Tachometer	
Galvanometer		Oscilloscope	
F) Recording Instruments			
Thermocouple		Recording Wattmeter	
H) Classification in Working Principle of Instrument			
PMMC		Moving Iron	
Dynamometer Type		Induction Type	

Practical No. 2: PMMC and MI Instruments

I Practical Significance

In the industry Electrical Engineering diploma graduate are expected to handle PMMC and MI instruments to measure basic parameters like voltage and current of field devices/equipments. In some situation it becomes necessary to identify the faulty components of the instruments. This practical will help you in acquiring necessary skills to identify the components of PMMC and MI instruments.

II Relevant Program Outcomes (POs)

- **Discipline knowledge:** Apply Electrical Engineering knowledge to solve broad based Electrical Engineering related problems.
- **Experiments and practice:** Plan to perform experiments and practices to use the results to solve broad-based Electrical Engineering problems.
- **Engineering tools:** Apply relevant Electrical technologies and tools with an understanding of the limitations.

III Competency and Practical Skills

This practical is expected to develop the following skills for the industry identified competency: **‘Use relevant measuring instrument in different electrical applications’**

- i. Use measuring instruments.
- ii. Identify the components of measuring instruments.

IV Relevant Course Outcome(s)

- a. Identify electrical measuring instrument.
- b. Use measuring instruments.

V Practical Outcome

Identify the components of PMMC and MI instruments.

VI Relevant Affective domain related Outcome(s)

- a. Follow safety practices.
- b. Maintain tools and equipment.

VII Minimum Theoretical Background

P.M.M.C. instrument (construction):-

The instrument has a Deflecting system, a Controlling system and a Damping system.

The Deflecting System consists of a permanent magnet made of Alnico, a core of soft iron and moving coil of enameled copper wire. The moving coil has a thin cross-section and about 50 - 100 turns. It is wound on a rectangular aluminum former. The former is pivoted on a spindle. The moving coil is free to rotate in the gap of permanent magnet and fixed core. Controlling system consists of springs, called control springs, made of phosphor bronze. (Springs also act as the leads for the current). Damping torque is produced by the principle of eddy current. Eddy current damping system Generates eddy currents in the permanent magnet and damps the oscillations of indicating pointer by providing force in the opposite direction.

P.M.M.C. instrument (operation):-

A deflecting torque is produced proportional to current through the moving coil which moves in the field of permanent magnet. Control springs produce the controlling torque which is proportional to angle of deflection.

Eddy currents circulating in the aluminum former produce damping torque which is proportional to eddy emf induced in it.

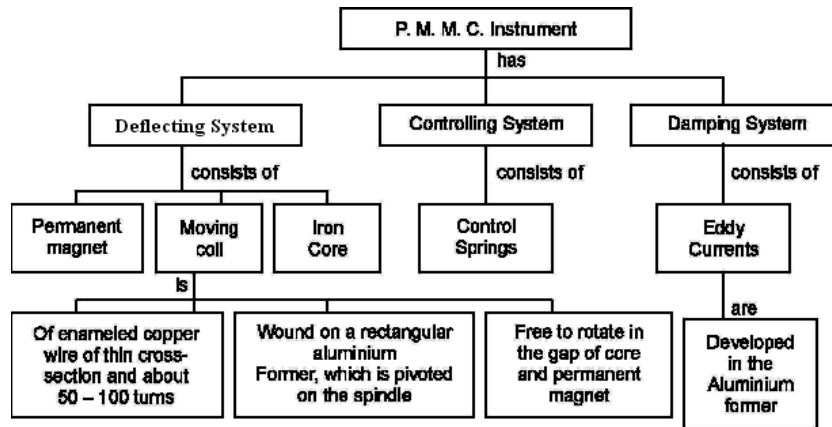

Figure1: Structure of PMMC instruments

Répulsion type MI instrument (construction) :-

The instrument has Deflecting system, controlling system and Damping system.

Deflecting system consists of a circular coil. A soft iron piece called fixed iron is attached to the coil from inside. Spindle is along the axis of coil. Another soft iron piece called as moving iron is attached to the spindle. Controlling system consists of springs, called control springs made of phosphor bronze. Damping system consists of air friction damping.

Repulsion type M. I. Instrument (operation):-

While coil carries current, the soft iron pieces get magnetized. Similar poles are formed on the nearer faces of soft iron pieces and they repel each other. Thus the deflecting torque is due to the repulsion and it is proportional to square of the current through the coil. Control spring provide the controlling torque which is proportional to angle of deflection. Air friction damping is provided to the instrument. So damping torque is proportional to movement of piston in air chamber

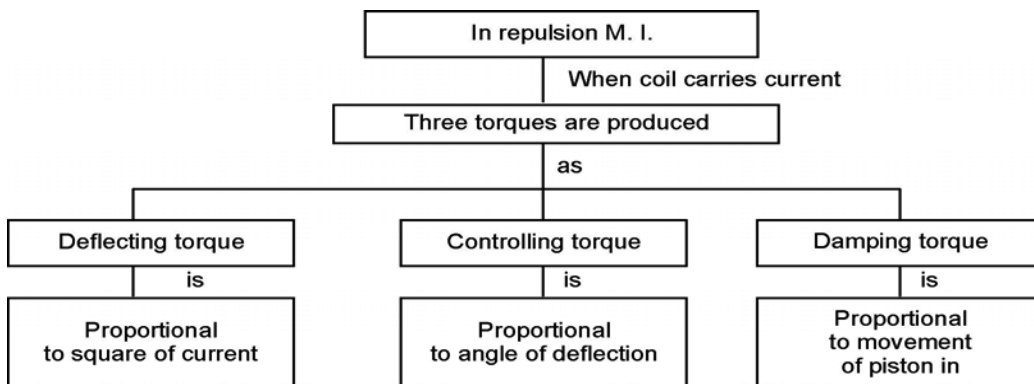

Figure2: Structure of MI (repulsion type) instruments

VIII Practical set-up / Circuit diagram / Work Situation

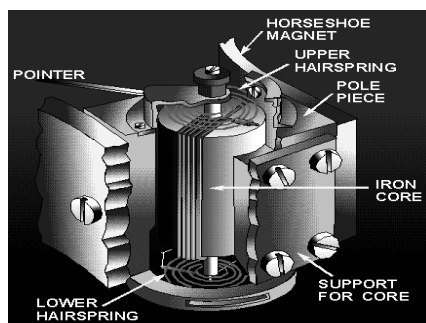

Figure 3 Internal structure of PMMC Instruments

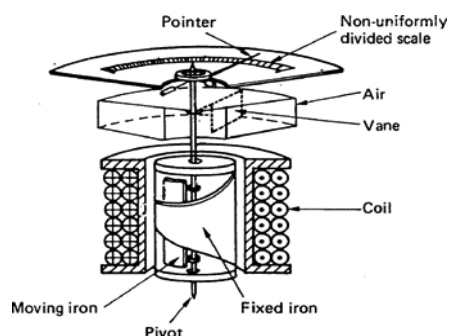

Figure 4 Internal structure repulsion type MI instruments

IX Resources Required

S. No.	Name of Resource	Suggested Broad Specification	Quantity
1	PMMC Instruments	Working model Voltmeter, Ammeter	1 No.
2	MI Instruments	Working model Voltmeter, Ammeter	1 No.
3	Screw Driver	Standard size	1 No.
4	Plier	Standard size	1 No.

X Precautions to be Followed

1. Use proper screw driver.
2. Don't exert more pressure while opening the screw.

XI Procedure

Part A: - Identification of PMMC instrument

1. Observe the given working model of P.M.M.C. instrument.
2. Observe Deflecting, Controlling and Damping systems.
3. Draw sketch showing all parts of the instrument and label them.
(Note:-Use blank sheet provided to draw the sketch)

Part B:- Identification of MI instruments

1. Observe the given working model of M. I. instrument.
2. Observe Deflecting, Controlling and Damping systems.
3. Draw sketch showing all parts of the instrument and label them.
(Note:- Use blank sheet provided to draw the sketch)

XII Resources Used

S. No	Name of Resource	Broad Specifications		Quantity	Remarks (If any)
		Make	Details		
1.					
2.					
3.					

XIII Actual Procedure Followed (use blank sheet provided if space not sufficient)

.....

XIV Observations and Calculations (use blank sheet provided if space not sufficient)
 (Not applicable to this experiment)

.....

XV Results

.....

XVI Interpretation of Results (Give meaning of the above obtained results)

.....

XVII Conclusions (Actions/decisions to be taken based on the interpretation of results).

.....

XVIII Practical Related Questions: (Note:- Teacher should provide various questions related to practical- sample given)

1. State the constructional difference between PMMC and MI instrument.
2. Observe the scale of PMMC and MI instruments and comment on it.

XIX References / Suggestions for further reading

1. Experiments in Basic Electrical Engineering S.K.Bhattacharya K.M.Rastogi ISBN: 978-81-224-1041-6 New Age International Publications
2. <https://www.electrical4u.com/electrical-measuring-instruments-types-accuracy-precision-resolution-speed/>
3. Electrical Measurements and Measuring Instruments U. A. Bakshi A. V. Bakshi K. A. Bakshi ISBN 9788184314380 First Edition – 2008 Technical Publications Pune.

XX Suggested Assessment Scheme

Performance indicators		Weightage
Process related: 6 Marks		60%
1	Handling of the instruments	10 %
2	Identification of component/dial/scale	40 %
3	Measuring value using suitable instrument	0 %
4	Working in team	10 %
Product related: 4 Marks		40%
5	Writing result	10 %
6	Interpretation of result	00 %
7	Conclusions	00 %
8	Practical related questions	25 %
9	Submitting the journal in time	05%
Total (10 Marks)		100 %

Names of Student Team Members

1.
2.
3.

Marks Obtained			Dated signature of Teacher
Process Related(6)	Product Related(4)	Total (10)	

Practical No. 3: Troubleshoot PMMC and MI Instruments

I Practical Significance

In the industry Electrical Engineering diploma graduate are expected to troubleshoot measuring instruments. Therefore this practical will help you to acquire necessary skills.

II Relevant Program Outcomes (POs)

- **Discipline knowledge:** Apply Electrical Engineering knowledge to solve broad based Electrical Engineering related problems.
- **Experiments and practice:** Plan to perform experiments and practices to use the results to solve broad-based Electrical Engineering problems.
- **Engineering tools:** Apply relevant Electrical technologies and tools with an understanding of the limitations.

III Competency and Practical Skills

This practical is expected to develop the following skills for the industry identified competency: **'Use relevant measuring instrument in different electrical applications'**

- Use PMMC and MI instruments
- Troubleshoot PMMC and MI instruments

IV Relevant Course Outcome(s)

- Use measuring instruments.

V Practical Outcome

Troubleshoot PMMC and MI instruments.

VI Relevant Affective domain related Outcome(s)

- Follow safety practices.
- Maintain tools and equipment.

VII Minimum Theoretical Background

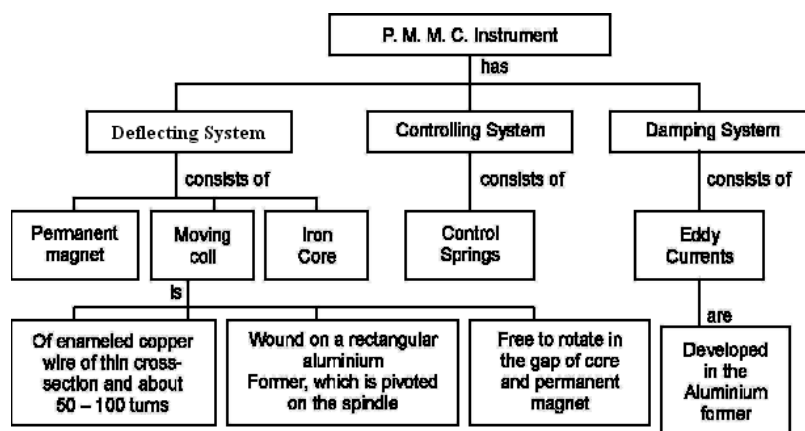

Figure1: Structure of PMMC instruments

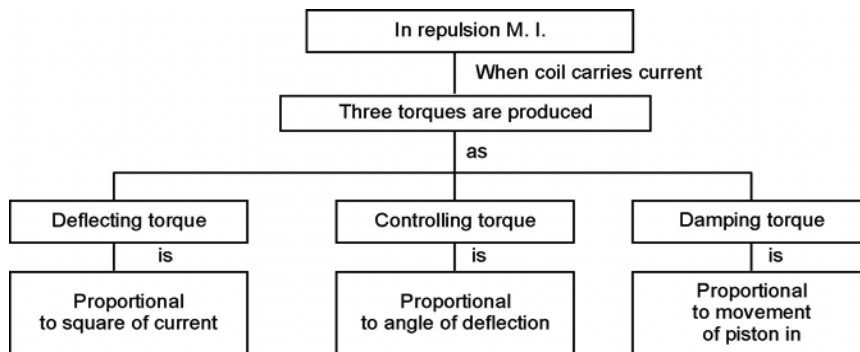

Figure2: Structure of MI (repulsion type) instruments

VIII Practical set-up / Circuit diagram / Work Situation

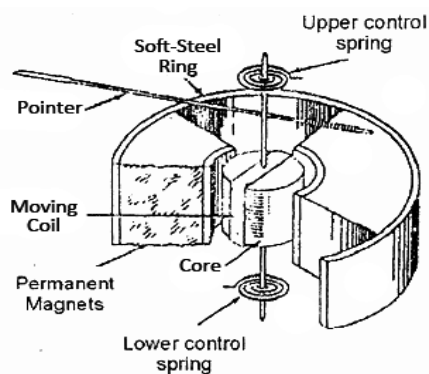

Figure 3 Internal structure of PMMC instrument:

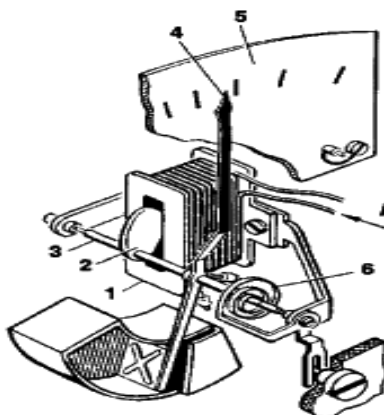

Figure 4 Internal structure of MI instrument:
 1. Coil, 2. Core, 3. Shaft, 4. Pointer, 5. Scale, 6. spring and I-current

IX Resources Required

S. No.	Name of Resource	Suggested Broad Specification	Quantity
1	Voltmeter	PMMC/MI	1 No.
2	Ammeter	PMMC/MI	1 No.

X Precautions to be Followed

1. Select proper range of meters.
2. Be careful while selecting PMMC/MI meters.
3. Don't increase the voltage/current beyond meters capacity
4. Don't touch the live wire

XI Problem Statement (to be provided by teacher, sample given here)

1. PMMC meter doesn't show deflection.
2. Pointer of MI instrument oscillates for a long time before it comes to final steady state position.

XII Procedure

.....

XIII Resources Used

S. No.	Name of Resource	Broad Specifications		Quantity	Remarks (If any)
		Make	Details		
1.					
2.					
3.					

XIV Actual Procedure Followed (use blank sheet provided if space not sufficient)

.....

XV Observations and Calculations (use blank sheet provided if space not sufficient)

Student should observe the troubles, find the causes and provide the remedial action

.....

XVI Results

.....

XVII Interpretation of Results (Give meaning of the above obtained results)

.....
.....
.....

XVIII Conclusions (Actions/decisions to be taken based on the interpretation of results).

.....
.....
.....

XIX Practical Related Questions: (Note:- Teacher should provide various questions related to practical- sample given)

1. State the reason for non deflection of instrument pointer.
2. State the reason for oscillations of pointer for a longer period before it comes to final steady state position.
3. “PMMC instruments can be used for measurement of AC quantities”. State true or false with justification.

(Space for answers)

.....
.....
.....
.....
.....
.....
.....
.....
.....
.....
.....
.....
.....
.....
.....
.....
.....
.....
.....
.....
.....
.....
.....

XX References / Suggestions for further reading

1. Experiments in Basic Electrical Engineering S.K.Bhattacharya K.M.Rastogi ISBN: 978-81-224-1041-6 New Age International Publications.
2. <https://encyclopedia2.thefreedictionary.com/Moving-Iron+Instrument>
3. Electrical Measurements and Measuring Instruments U. A. Bakshi A. V. Bakshi K. A. Bakshi ISBN 9788184314380 First Edition – 2008 Technical Publications Pune.

XXI Suggested Assessment Scheme

Performance indicators		Weightage
Process related: 6 Marks		60%
1	Handling of the instruments	10 %
2	Identification of component/dial/scale	20 %
3	Measuring value using suitable instrument	20 %
4	Working in team	10 %
Product related: 4 Marks		40%
5	Writing result	10 %
6	Interpretation of result	05 %
7	Conclusions	05 %
8	Practical related questions	15 %
9	Submitting the journal in time	05%
Total (10 Marks)		100 %

Names of Student Team Members

1.
2.
3.

Marks Obtained			Dated signature of Teacher
Process Related(6)	Product Related(4)	Total (10)	

Practical No. 4: Measurement of AC and DC Quantities

I Practical Significance

In the industry Electrical Engineering diploma graduate are expected to handle measuring instruments to measure electrical quantities. Therefore this practical will help you to acquire necessary skills.

II Relevant Program Outcomes (POs)

- **Discipline knowledge:** Apply Electrical Engineering knowledge to solve broad based Electrical Engineering related problems.
- **Experiments and practice:** Plan to perform experiments and practices to use the results to solve broad-based Electrical Engineering problems.
- **Engineering tools:** Apply relevant Electrical technologies and tools with an understanding of the limitations.

III Competency and Practical Skills

This practical is expected to develop the following skills for the industry identified competency '**Use relevant measuring instrument in different electrical applications**':

- Use voltmeter for measurement of voltage.
- Use ammeter for measurement of current.

IV Relevant Course Outcome(s)

- a. Identify electrical measuring instrument.
- b. Use voltmeter and ammeter for electrical measurement.

V Practical Outcome

Measure AC and DC quantities in a working circuit.

VI Relevant Affective domain related Outcome(s)

- a. Follow safety practices.
- b. Maintain tools and equipment.
- c. Follow ethical Practices.

VII Minimum Theoretical Background

A **voltmeter** is an instrument used for measuring electrical potential difference between two points in an electric circuit. Analog voltmeters move a pointer across a scale in proportion to the voltage of the circuit.

An **ammeter** (from **Ampere Meter**) is a measuring instrument used to measure the current in a circuit. Electric currents are measured in amperes (A), hence the name. Instruments used to measure smaller currents, in the milliamperere or microampere range, are designated as milliammeters or microammeters.

VIII Practical set-up / Circuit diagram / Work Situation

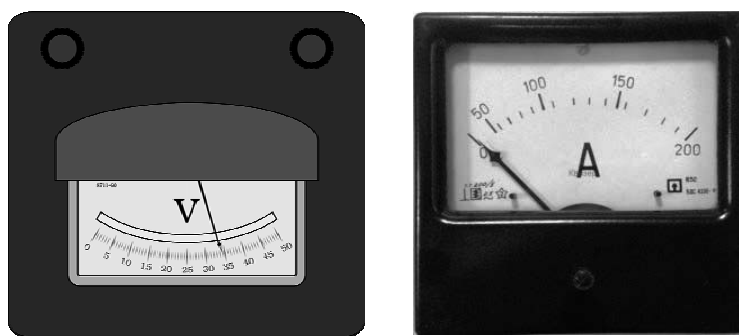

Figure 1 :Front View of Voltmeter and ammeter

1.0 Circuit Diagram: a) Measurement of AC quantities

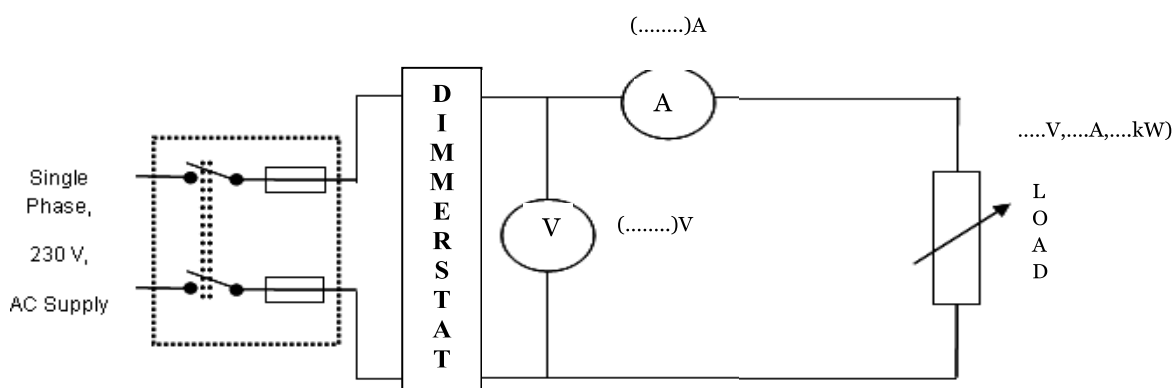

Figure 2 : Measurement of AC quantities

b) Measurement of DC quantities: - student should draw the circuit diagram
(Space for circuit diagram)

IX Resources Required

S. No.	Name of Resource	Suggested Broad Specification	Quantity
1	Ammeter	0 -1-10 A MI/PMMC	1 No.
2	Voltmeter	0- 50-75-150-300 V, MI/PMMC	1 No.
3	Resistive / lamp load	9A,230V,2.5 kW	1 No.
4	Single phase Variac	0-230V,4A	1 No.

X Precautions to be Followed

- 1 Select proper range of meters.
- 2 Be careful while selecting AC/DC meters
- 3 Don't increase the current beyond meters capacity
- 4 Don't touch the live wire
- 5 Use autotransformer to vary AC voltage for safety reason.

XI Procedure**a. Measurement of AC quantities**

1. Make the connections as per the circuit diagram.
2. Check and adjust zero setting of ammeter and voltmeter. (if any)
3. Keep the autotransformer at minimum position.
4. Switch on the supply.
5. Gradually increase the output of autotransformer up to rated voltage.
6. Switch on the load switch/ switches in steps.
7. Note voltmeter and ammeter readings in observation table.
8. Repeat step 6 and 7 four times.
9. Switch off the load and gradually decrease the output of autotransformer to minimum.
10. Switch off the supply.

b. Measurement of DC quantities: (Use separate sheet if space is not enough)

.....

.....

.....

XII Resources Used (Students should write the resources required)

S. No.	Name of Resource	Broad Specifications		Quantity	Remarks (If any)
		Make	Details		
1.					
2.					
3.					
4.					
5.					

XIII Actual Procedure Followed (use blank sheet provided if space not sufficient)

.....

.....

.....

XIV Observations and Calculations (use blank sheet provided if space not sufficient)**a) Measurement of AC quantities**

S.N.	Voltmeter reading	Ammeter reading
	(V)	(A)
1		
2		
3		
4		
5		

b) Measurement of DC quantities

S.N.	Voltmeter reading	Ammeter reading
	(V)	(A)
1		
2		
3		
4		
5		

XV Results

.....

XVI Interpretation of Results (Give meaning of the above obtained results)

.....

XVII Conclusions (Actions/decisions to be taken based on the interpretation of results).

.....

XVIII Practical Related Questions (Note:-Teacher should provide various questions related to practical- sample given)

1. "MI" instrument can be used for measurement of AC current". State whether this statement is true or false. Justify your answer.
2. "Ammeter is always connected in series and voltmeter in parallel". Justify the statement.

(Space for answers)

.....

.....

.....

.....

.....

.....

.....

.....

.....

XIX References / Suggestions for further reading

1. Experiments in Basic Electrical Engineering S.K.Bhattacharya K.M.Rastogi ISBN: 978-81-224-1041-6 New Age International Publications
2. <https://en.wikipedia.org/wiki/Ammeter/voltmeter>
3. Electrical Measurements and Measuring Instruments U. A. Bakshi A. V. Bakshi K. A. Bakshi ISBN 9788184314380 First Edition – 2008 Technical Publications Pune

XX Suggested Assessment Scheme

Performance indicators		Weightage
Process related: 6 Marks		60%
1	Handling of the instruments	10 %
2	Identification of component/dial/scale	20 %
3	Measuring value using suitable instrument	20 %
4	Working in team	10 %
Product related: 4 Marks		40%
5	Writing result	10 %
6	Interpretation of result	05 %
7	Conclusions	05 %
8	Practical related questions	15 %
9	Submitting the journal in time	05%
Total (10 Marks)		100 %

Names of Student Team Members

1.
2.
3.

Marks Obtained			Dated signature of Teacher
Process Related(6)	Product Related(4)	Total (10)	

Practical No. 5: Extension of Range of Ammeter and Voltmeter

I Practical Significance

In the industry Electrical Engineering diploma graduate are expected to measure high value of voltage and current. This higher value of current and voltage can be measured using low range meters by extending their range by using shunt & multiplier and/or CT & PT respectively. Therefore this practical will help you to acquire necessary skills.

II Relevant Program Outcomes (POs)

- **Discipline knowledge:** Apply Electrical Engineering knowledge to solve broad based Electrical Engineering related problems.
- **Experiments and practice:** Plan to perform experiments and practices to use the results to solve broad-based Electrical Engineering problems.
- **Engineering tools:** Apply relevant Electrical technologies and tools with an understanding of the limitations.

III Competency and Practical Skills

This practical is expected to develop the following skills for the industry identified competency: **'Use relevant measuring instrument in different electrical applications'**

- Use low range meters for higher value measurement.
- Connect CT/PT/Shunt/Multiplier.
- Measure voltage and current.

IV Relevant Course Outcome(s)

- Identify electrical measuring instrument (CT and PT).
- Use voltmeter and ammeter for electrical measurement.
- Use measuring instruments.

V Practical Outcome

Extend range of ammeter and voltmeter by using (i) shunt and multiplier (ii) CT and PT.

VI Relevant Affective domain related Outcome(s)

- a. Follow safety practices.
- b. Maintain tools and equipment.
- c. Follow ethical Practices.

VII Minimum Theoretical Background

The ranges of electrical measuring instruments (whether ammeter, voltmeter or any other type of meters) are limited by the currents, which be carried by the coils of the instruments safely. For example, the moving coils of the instruments can carry maximum current of about 50 mA safely and the potential drop across the moving coil is about 50 mV. Hence, it becomes necessary that the current and voltage being measured be reduced and brought within the range of instrument.

There are four common devices used for extending the range of the instruments, namely

1. Shunts
2. Multipliers
3. Current transformers
4. Potential transformers

1. Shunts: The range of ammeters can be extended by connecting a low resistance, called shunts, connected in parallel with ammeter. The shunt bypasses the extra current and allows only safe current to flow through the ammeter.

2. Multipliers: The range of voltmeter can be extended by connecting a high resistance, called multiplier in series with the voltmeter coil. The multiplier limits the current through the meter so that it does not exceed the value of full scale deflection and thus prevents the movement from being damaged. Materials used for multipliers are manganin and constantan.

3. Current Transformer: Current Transformer is employed along with a low range A. C. ammeter so as to measure high value of A. C. current wherever and whenever the current of an A. C. circuit exceeds the safe working current of the measuring instrument (for e.g. ammeter, wattmeter or energy meter).

The high value of current to be measured is equal to the reading of low range A.C.

Ammeter multiplied by Current Ratio (C. R.) of the C. T., where

$$\text{Current Ratio (C.R.)} = \frac{\text{Rated Primary Current}}{\text{Rated Secondary Current}}$$

4. Potential Transformer: Potential Transformer is employed along with a low range A. C. voltmeter so as to measure high value of A. C. voltage wherever and whenever the voltage of an A. C. circuit exceeds the safe working voltage of the instrument.

High value of voltage to be measured is equal to the reading of low range A. C.

Voltmeter multiplied by Voltage Ratio (V. R.) of the P. T. where,

$$\text{Voltage Ratio (V.R.)} = \frac{\text{Rated Primary Voltage}}{\text{Rated Secondary Voltage}}$$

VIII Practical set-up / Circuit diagram / Work Situation

- a) Extend range of ammeter by using CT

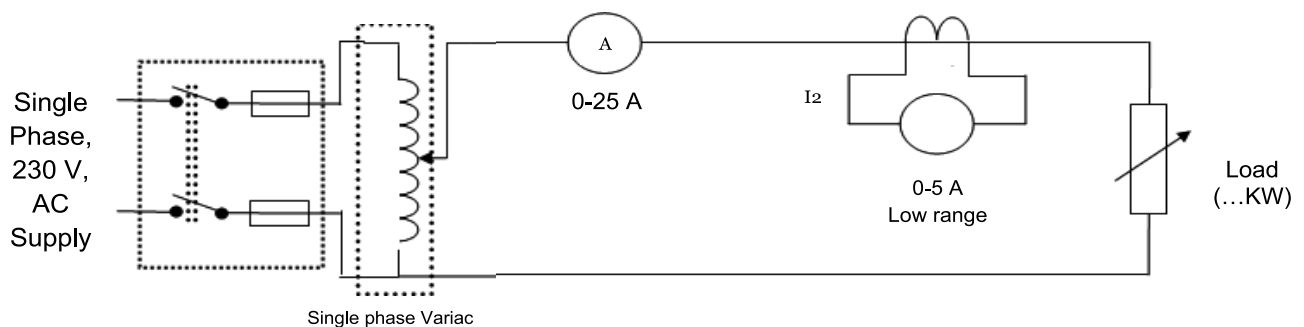

Figure 1: Extend range of ammeter using CT

b) Extend range of voltmeter by using PT

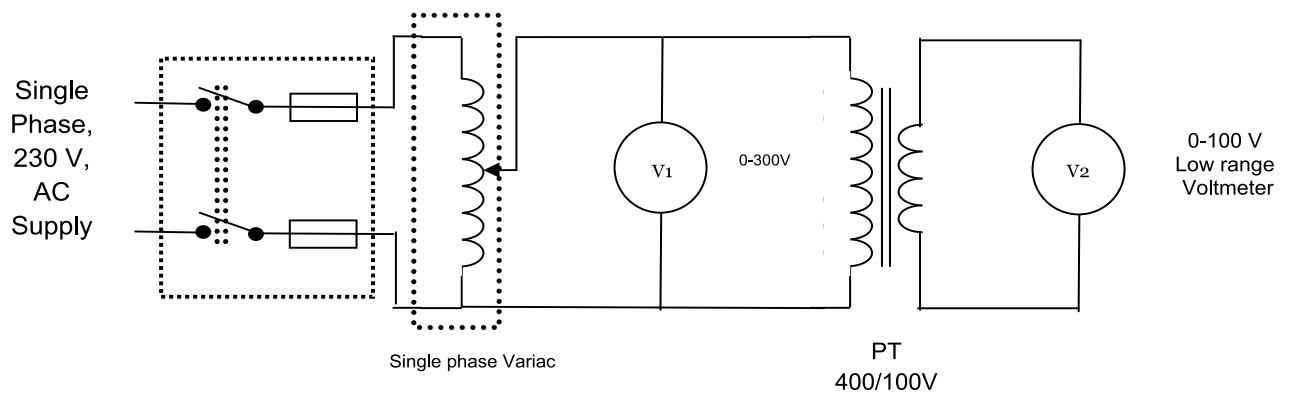

Figure 2: Extend range of voltmeter using PT

c) Extend range of ammeter and voltmeter by using shunt and multiplier
(Student should draw circuit diagram)

(Space for circuit diagram)

IX Resources Required

S. No.	Name of Resource	Suggested Broad Specification	Quantity
1	Current Transformer	25/5 A	1 No.
2	Potential Transformer	400/100 V	1 No.
3	Analog Ammeter	(0-5A, 0-10A & 0-25A) AC/DC	1 No.
4	Analog voltmeter	(0-100V, 0-300V) AC/DC	1 No.
5	Resistive Load /Lamp Load	5 kW, 230V	1 No.
6	Single Phase variac	0-270 V, 25 A	1 No.
7	Digital Multimeter	Standard Ranges	1 No.

X Precautions to be Followed

- 1 Select proper range of meters.
- 2 Be careful while selecting AC/DC meters
- 3 Don't increase the current beyond meters capacity
- 4 Use dimmerstat for voltage variation in AC
- 5 Don't touch the live wire.
- 6 Secondary of CT should always be short circuited.

XI Procedure**1. Extend range of ammeter by using CT**

1. Make the connections as per Figure 1.
2. Check and adjust zero setting of ammeter and voltmeter. (if any)
3. Keep the autotransformer at minimum position.
4. Put the electrical load in off condition.
5. Switch on the AC supply.
6. Gradually increase the output of autotransformer up to rated voltage.
7. Switch on the load switch/ switches in steps.
8. Note ammeter readings I_1 and I_2 in observation table.
9. Repeat step 7 and 8 four times.
10. Switch off the load and gradually decrease the output of autotransformer to minimum.
11. Switch off the supply.

2. Extend range of voltmeter by using PT

1. Make the connections as per Figure 2.
2. Check and adjust zero setting of voltmeter. (if any)
3. Keep the autotransformer at minimum position.
4. Switch on the AC supply.
5. Gradually increase the output of autotransformer in steps (eg-100V, 150V, 200V, 230V)
6. Note voltmeter readings V_1 and V_2 in observation table.
7. Switch off the supply.

3. Extend range of ammeter by using shunt (Student should write procedure)
 1.
 2.
 3.
 4.
 5.

4. Extend range of voltmeter by using multiplier (Student should write procedure)
 1.
 2.
 3.
 4.
 5.

XII Resources Used

S. No	Name of Resource	Broad Specifications		Quantity	Remarks (If any)
		Make	Details		
1.					
2.					
3.					

XIII Actual Procedure Followed (use blank sheet provided if space not sufficient)

.....

XIV Observations and Calculations (use blank sheet provided if space not sufficient)

- a. Extend range of ammeter by using CT

Current Ratio of C. T. =

Sr No.	I ₁	I ₂	I ₁ / I ₂	Actual current = I ₂ x C.R. Amps.
1				
2				
3				
4				

- b. Extend range of voltmeter by using PT

Voltage ratio of P.T. =

Sr No.	Reading of Voltmeter V_1	Reading of Voltmeter V_2	V_1 / V_2	Actual voltage = $V_2 \times V.R.$ volts
1				
2				
3				
4				

- c. Extend range of ammeter and voltmeter by using shunt and multiplier (Student should draw observation table)

(Space for observation table)

XV Results

.....
.....
.....

XVI Interpretation of Results (Give meaning of the above obtained results)

.....
.....
.....

XVII Conclusions (Actions/decisions to be taken based on the interpretation of results).

.....
.....
.....

XVIII Practical Related Questions (Note:-Teacher should provide various questions related to practical- sample given)

- a. Current up to 250 amperes is to be measured with a low range ammeter. Suggest the method and range of the instruments required. Draw the circuit diagram.
- b. “Secondary of CT should never be kept open circuited”. Justify the statement.
- c. Voltages up to 11kV are to be measured with low range voltmeter. Suggest the method and range of the instruments required. Draw the circuit diagram.

(Space for answers)

.....
.....
.....
.....
.....
.....
.....
.....
.....
.....
.....
.....
.....
.....
.....
.....
.....
.....
.....
.....
.....
.....
.....

XIX References / Suggestions for further reading

1. Experiments in Basic Electrical Engineering S.K.Bhattacharya K.M.Rastogi ISBN: 978-81-224-1041-6 New Age International Publications
2. <http://4electrical.blogspot.in/2014/12/explanation-of-extending-range-of.html>
3. Electrical Measurements and Measuring Instruments U. A. Bakshi A. V. Bakshi. K. A. Bakshi ISBN 9788184314380 First Edition – 2008 Technical Publications Pune

XX Suggested Assessment Scheme

Performance indicators		Weightage
Process related: 6 Marks		60%
1	Handling of the instruments	10 %
2	Identification of component/dial/scale	20 %
3	Measuring value using suitable instrument	20 %
4	Working in team	10 %
Product related: 4 Marks		40%
5	Writing result	10 %
6	Interpretation of result	05 %
7	Conclusions	05 %
8	Practical related questions	15 %
9	Submitting the journal in time	05%
Total (10 Marks)		100 %

Names of Student Team Members

1.
2.
3.

Marks Obtained			Dated signature of Teacher
Process Related(6)	Product Related(4)	Total (10)	

Practical No. 6: Clamp-On Meter

I Practical Significance

In the industry Electrical Engineering diploma graduate are expected to handle clamp on meter to measure basic parameters like voltage and current of field devices. Therefore this practical will help you to acquire necessary skills.

II Relevant Program Outcomes (POs)

- **Discipline knowledge:** Apply Electrical Engineering knowledge to solve broad based Electrical Engineering related problems.
- **Experiments and practice:** Plan to perform experiments and practices to use the results to solve broad-based Electrical Engineering problems.
- **Engineering tools:** Apply relevant Electrical technologies and tools with an understanding of the limitations.

III Competency and Practical Skills

This practical is expected to develop the following skills for the industry identified competency ‘Use relevant measuring instrument in different electrical applications’

- Use clamp on meter for various measurements.

IV Relevant Course Outcome(s)

- Identify electrical measuring instrument.
- Use measuring instruments

V Practical Outcome

Use Clamp-on meter for measurement of AC/DC current and AC/DC voltage.

VI Relevant Affective domain related Outcome(s)

- a. Follow safety practices.
- b. Maintain tools and equipment.

VII Minimum Theoretical Background

Clamp meters works on the principle of magnetic induction to make non-contact AC current measurements when electric current flowing through a wire produces a magnetic field. Since alternating current frequently reverses polarity, it causes dynamic fluctuations in the magnetic field which are proportional to the current flow. A current transformer inside the clamp meter senses the magnetic fluctuations and converts the value to an AC current reading. This type of measurement is convenient for measuring very high AC currents.

Direct current, however, flows through conductors in a fixed polarity. Consequently, the magnetic field around the conductor does not change and conventional clamp meters will register no reading. DC clamp meters work on the principle of the Hall Effect. Hall effect sensors sense the magnetic field caused by current flow which causes a small voltage across the Hall effect sensor. That voltage, which is proportional to current is then amplified and measured.

Clamp meters often include other sensors such as voltmeters, ohmmeters, etc. which increase the versatility of the instrument. These other sensors use test leads which plug

into the clamp meter. As only current measurements can be made with the clamp, other measurements do not benefit from the non-contact nature of the clamp.

VIII Practical set-up / Circuit diagram / Work Situation

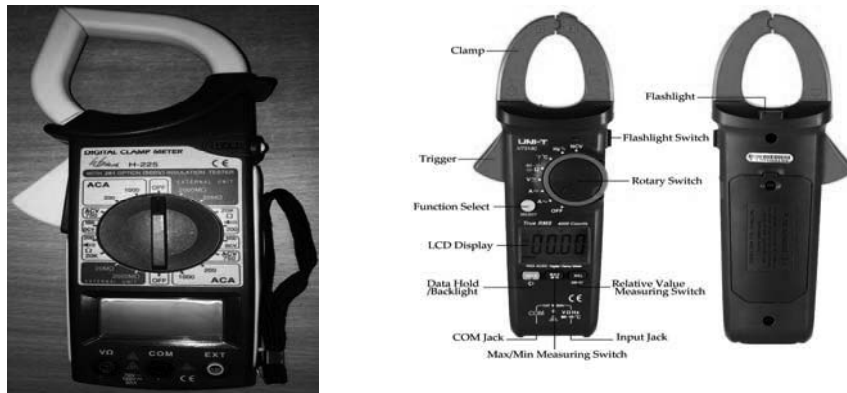

Figure 1: Front View of clamp-on meter

Circuit Diagram:-

1. Measurement of AC current:- (Connect digital multi-meter as ammeter)

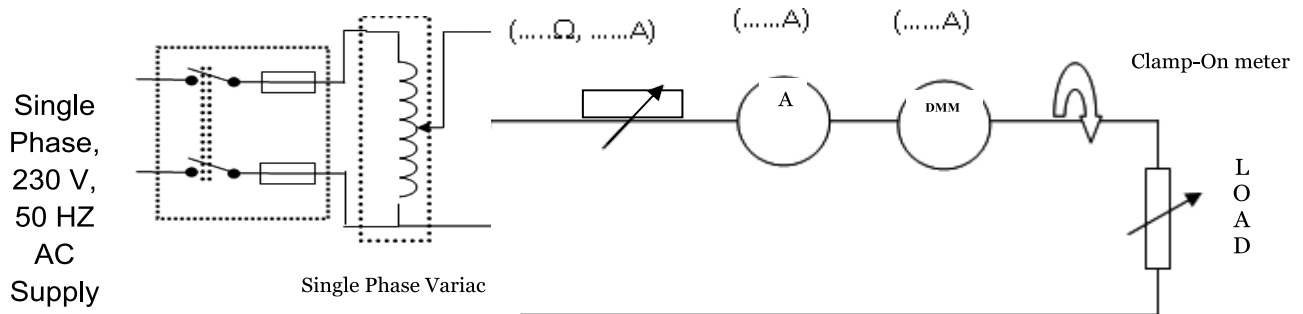

Figure 2: Measurement of AC current

2. Measurement of AC voltage- (Circuit diagram to be drawn by student)
(Space for circuit diagram)

3. Measurement of DC current-(Circuit diagram to be drawn by student)
(Space for circuit diagram)

4. Measurement of DC voltage-(Circuit diagram to be drawn by student)
(Space for circuit diagram)

IX Resources Required

S. No.	Name of Resource	Suggested Broad Specification	Quantity
1	Clamp on meter	Voltage: DC: 600 volts; AC: 600 volts, Current: DC: 25 amps; AC: 25 amps	1 No.
2	Analog ammeters	(0-5A) and (0-10A) AC,(0-5A) DC	1 No.
3	Analog voltmeter	(0-300V)	1 No.
4	Load 5 kW/Lamp Load	5 kW/Lamp Load	1 No.
5	Rheostat	270 V, 5A	1 No.
6	Single phase variac	0-230 V, 4A	1 No.

X Precautions to be Followed

- 1 Select proper range of meters.
- 2 Be careful while selecting AC/DC meters
- 3 Don't increase the current beyond meters capacity
- 4 Use dimmerstat for voltage variation in AC
- 5 Don't touch the live wire

XI Procedure**a) AC Measurement:- i) AC current measurement**

1. Connect as per circuit shown in Figure 2 for measurement of AC current.
2. Initially keep dimmerstat at minimum position.
3. Switch ON the supply
4. Increase the output voltage of dimmerstat gradually up to rated voltage.
5. Switch on the load bank switches gradually.
6. Record the current in the observation table after measuring with the clamp on meter
7. Record the ammeter reading
8. Record the digital multi-meter reading (used as ammeter)
9. Compare the reading of conventional Measuring instrument with clamp-on meter reading
10. Increase the load by switching on one more switch of the load bank.
11. Repeat steps 6-10 four times.

ii) AC Voltage Measurement

1. Make the connection as per circuit shown in Figure 3(to be drawn by student)for measurement of AC voltage.
2. Initially keep dimmerstat at minimum position.
3. Switch ON the supply
4. Increase the output voltage of dimmerstat gradually up to rated voltage.
5. Switch on the load bank switches gradually.

6. Record the voltage in the observation table after measuring with the clamp on meter
7. Record the voltmeter reading
8. Record the digital multimeter reading(used as voltmeter)
9. Compare the reading of conventional Measuring instrument with clamp-on meter reading.
10. Increase the load by switching on one more switch of the load bank.
11. Repeat steps 6-10 four times.

b) DC Measurement:- i) DC current measurement

.....

ii) DC voltage measurement (Student should write the procedure)

.....

XII Resources Used(Student should write the resources required)

S. No	Name of Resource	Broad Specifications		Quantity	Remarks (If any)
		Make	Details		
1.					
2.					
3.					

XIII Actual Procedure Followed (use blank sheet provided if space not sufficient)

.....

XIV Observations and Calculations (use blank sheet provided if space not sufficient)

a) AC Current Measurement

S N	Clamp-on meter reading	Ammeter reading	DMM Reading
1			
2			
3			
4			

b) AC Voltage Measurement

S N	Clamp-on meter reading	Ammeter reading	DMM Reading
1			
2			
3			
4			

c) DC current Measurement

S N	Clamp-on meter reading	Ammeter reading	DMM Reading
1			
2			
3			
4			

d) DC voltage Measurement

S N	Clamp-on meter reading	Ammeter reading	DMM Reading
1			
2			
3			
4			

XV Results

.....

XVI Interpretation of Results (Give meaning of the above obtained results)

.....

XVII Conclusions (Actions/decisions to be taken based on the interpretation of results).

.....

XVIII Practical Related Questions (Note:-Teacher should provide various questions related to practical- sample given)

1. List the minimum and maximum range of current that can be read with clamp on meter given to you.

.....

.....

.....

.....

.....

.....

.....

XIX References / Suggestions for further reading

1. Experiments in Basic Electrical Engineering S.K.Bhattacharya K.M.Rastogi ISBN: 978-81-224-1041-6 New Age International Publications
2. https://en.wikipedia.org/wiki/Current_clamp
3. Electrical Measurements and Measuring Instruments U. A. Bakshi A. V. Bakshi K. A. Bakshi ISBN 9788184314380 First Edition – 2008 Technical Publications Pune

XX Suggested Assessment Scheme

Performance indicators		Weightage
Process related: 6 Marks		60%
1	Handling of the instruments	10 %
2	Identification of component/dial/scale	20 %
3	Measuring value using suitable instrument	20 %
4	Working in team	10 %
Product related: 4 Marks		40%
5	Writing result	10 %
6	Interpretation of result	05 %
7	Conclusions	05 %
8	Practical related questions	15 %
9	Submitting the journal in time	05%
Total (10 Marks)		100 %

Names of Student Team Members

1.
2.
3.

Marks Obtained			Dated signature of Teacher
Process Related(6)	Product Related(4)	Total (10)	

Practical No. 7: Single Phase Power Measurement

I Practical Significance

In the industry Electrical Engineering diploma graduate are expected to handle measuring instruments to measure power of field devices. Therefore this practical will help you to acquire necessary skills.

II Relevant Program Outcomes (POs)

- **Discipline knowledge:** Apply Electrical Engineering knowledge to solve broad based Electrical Engineering related problems.
- **Experiments and practice:** Plan to perform experiments and practices to use the results to solve broad-based Electrical Engineering problems.
- **Engineering tools:** Apply relevant Electrical technologies and tools with an understanding of the limitations.

III Competency and Practical Skills

This practical is expected to develop the following skills for the industry identified competency ‘Use relevant measuring instrument in different electrical applications’:

- Use wattmeter for single phase power measurement

IV Relevant Course Outcome(s)

- Use wattmeter for electrical power measurement.

V Practical Outcome

Use electro-dynamic watt-meter for measurement of power in a single phase circuit

VI Relevant Affective domain related Outcome(s)

- a. Follow safety practices.
- b. Maintain tools and equipment.
- c. Follow ethical Practices.

VII Minimum Theoretical Background

In dynamometer type instrument deflecting torque is produced by magnetic effect of electric current. Control torque is provided by control springs. Damping torque is provided by Air Friction damping. In a dynamometer type wattmeter the fixed coil (current coil) is connected in series with the load. This coil is divided in to two parts and they are kept parallel to each other. The coil is thick in cross section and has lesser number of turns. The moving coil (pressure coil) is connected across the load. It is thin in cross - section and has hundreds of turns. It has a high non - inductive resistance in series with it.

Multiplied factor of wattmeter

As different ranges of voltage and current are available in wattmeter therefore to calculate actual power, multiplied factor should be used. The multiplied factor of watt meter is given by the product of voltage range, current range and rated power factor of watt meter, divided by the full scale deflection of wattmeter.

$$\text{Multiplied factor} = \frac{\text{Voltage Range} \times \text{Current Range} \times \text{Rated Power Factor}}{\text{Full Scale Deflection}}$$

VIII Practical set-up / Circuit diagram / Work Situation



Figure 1 :Front View of Single phase wattmeter

1.0 Circuit Diagram:

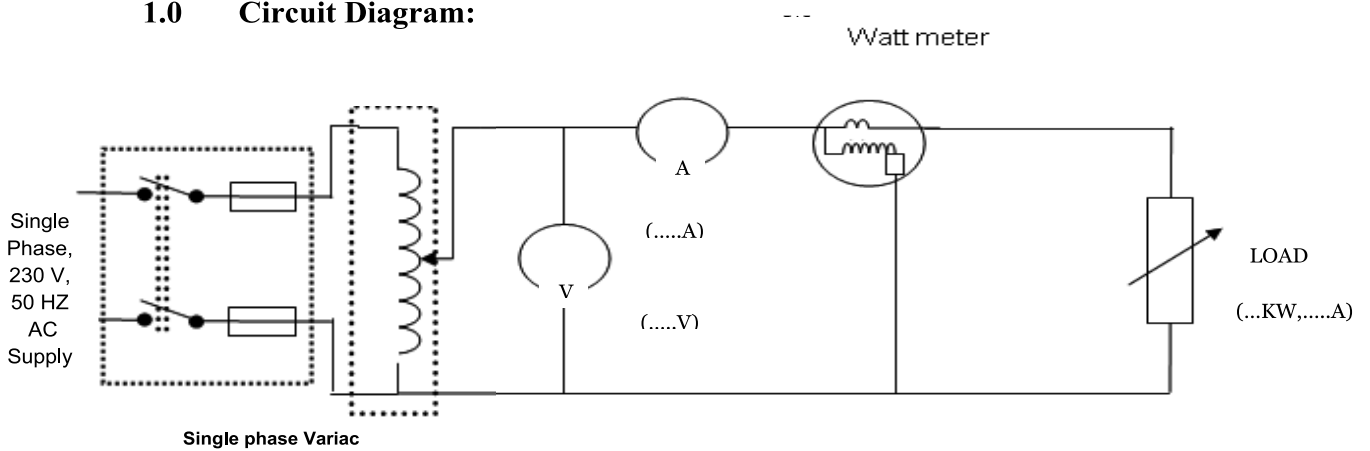

Figure 2 :Measurement of power in single phase circuit

IX Resources Required

S. No.	Name of Resource	Suggested Broad Specification	Quantity
1	Ammeter	0 - 10 A MI	1 No.
2	Voltmeter	0- 300 V, MI	1 No.
3	Watt-meter	10 A, 300 V, 1250 W	1 No.
4	Resistive / lamp load	12 A,2.5 KW	1 No.
5	Single phase variac	0-270V,10A	1 No.

X Precautions to be Followed

- 1 Select proper range of meters.
- 2 Be careful while selecting AC/DC meters
- 3 Don't increase the current beyond meters capacity
- 4 Don't touch the live wire
- 5 Use autotransformer to vary voltage for safety reason.

XI Procedure

1. Make the connections as per Figure 2.
2. Set the wattmeter to low current range/ high current range as per requirement.
3. Calculate multiplying factor of wattmeter and record the same in observation table.
4. Check and adjust zero setting of wattmeter, ammeter and voltmeter. (if any)
5. Keep the autotransformer at minimum position.
6. Put the electrical load in off condition.
7. Switch on the supply.
8. Gradually increase the output of autotransformer up to rated voltage
9. Switch on the load switch/ switches in steps.
10. Note voltmeter, ammeter & wattmeter readings in observation table.
11. Repeat step 9-10 four times.
12. Switch off the supply and load.
13. Calculate the power in the circuit using formula.

XII Resources Used (Student should write the resources required)

S. No.	Name of Resource	Broad Specifications		Quantity	Remarks (If any)
		Make	Details		
1.					
2.					
3.					
4.					
5.					

XIII Actual Procedure Followed (use blank sheet provided if space not sufficient)

.....

XIV Observations and Calculations (use blank sheet provided if space not sufficient)

$$\text{Multiplying factor} = \frac{\text{Voltage Range} \times \text{Current Range} \times \text{Rated Power Factor}}{\text{Full Scale Deflection}}$$

M.F. =

=

For Resistive load Cos Φ=1

S. N.	Ammeter reading (A)	Voltmeter reading (V)	Calculated power = V x I x Cosφ (W)	Watt-meter reading (W)	Actual measured power = W x M.F. (W)
1					
2					
3					
4					

XV Results

.....
.....
.....

XVI Interpretation of Results (Give meaning of the above obtained results)

.....
.....
.....

XVII Conclusions (Actions/decisions to be taken based on the interpretation of results).

.....
.....
.....

XVIII Practical Related Questions(Note:-Teacher should provide various questions related to practical- sample given)

- 1. In a circuit power is measured with a wattmeter with 15A, 400V, 1500 Watts F.S.D. The reading was 750Watts. What is the power consumed by load?
- 2. “Watt meters are not used for measuring power in D. C. circuits”. State whether the given statement is true or false. Give reasons.
(Space for answers)

.....
.....
.....
.....
.....
.....
.....
.....
.....
.....
.....
.....
.....
.....
.....
.....
.....
.....
.....
.....

XIX References / Suggestions for further reading

1. Experiments in Basic Electrical Engineering S.K.Bhattacharya K.M.Rastogi ISBN: 978-81-224-1041-6 New Age International Publications
2. <https://www.edn.com/design/test-and-measurement/4392053/How-to-Measure-Electrical-Power>
3. Electrical Measurements and Measuring Instruments U. A. Bakshi A. V. Bakshi K. A. Bakshi ISBN 9788184314380 First Edition – 2008 Technical Publications Pune

XX Suggested Assessment Scheme

Performance indicators		Weightage
Process related: 6 Marks		60%
1	Handling of the instruments	10 %
2	Identification of component/dial/scale	20 %
3	Measuring value using suitable instrument	20 %
4	Working in team	10 %
Product related: 4 Marks		40%
5	Writing result	10 %
6	Interpretation of result	05 %
7	Conclusions	05 %
8	Practical related questions	15 %
9	Submitting the journal in time	05%
Total (10 Marks)		100 %

Names of Student Team Members

1.
2.
3.

Marks Obtained			Dated signature of Teacher
Process Related(6)	Product Related(4)	Total (10)	

Practical No. 8: Measuring three phase active and reactive power

I Practical Significance

In the industry Electrical Engineering diploma graduate are expected to handle measuring instruments to measure active and reactive power in 3-phase field devices. Therefore this practical will help you to acquire necessary skills.

II Relevant Program Outcomes (POs)

- **Discipline knowledge:** Apply Electrical Engineering knowledge to solve broad based Electrical Engineering related problems.
- **Experiments and practice:** Plan to perform experiments and practices to use the results to solve broad-based Electrical Engineering problems.
- **Engineering tools:** Apply relevant Electrical technologies and tools with an understanding of the limitations.

III Competency and Practical Skills

This practical is expected to develop the following skills for the industry identified competency: **‘Use relevant measuring instrument in different electrical applications’**

- i. Select relevant wattmeter
- ii. Measure active and reactive power.

IV Relevant Course Outcome(s)

- Use wattmeter for electrical power measurement.

V Practical Outcome

Use single wattmeter for measurement of active and reactive power of three phase balanced load.

VI Relevant Affective domain related Outcome(s)

- a. Follow safety practices.
- b. Practice good housekeeping.
- c. Maintain tools and equipment.

VII Minimum Theoretical Background

This method can be used to measure power in 3 phase balanced load condition only. The current coil of wattmeter is connected in one of the lines and one end of pressure coil is connected to the same line. The readings are taken by connecting other terminal of pressure coil alternately to other two lines. The sum of these two readings gives active power.

The current coil of wattmeter is connected in one of the lines and pressure coil is connected across remaining two lines. The wattmeter reads reactive power.

VIII Practical set-up / Circuit diagram / Work Situation

1. Measure active power of three-phase balanced load using single wattmeter.

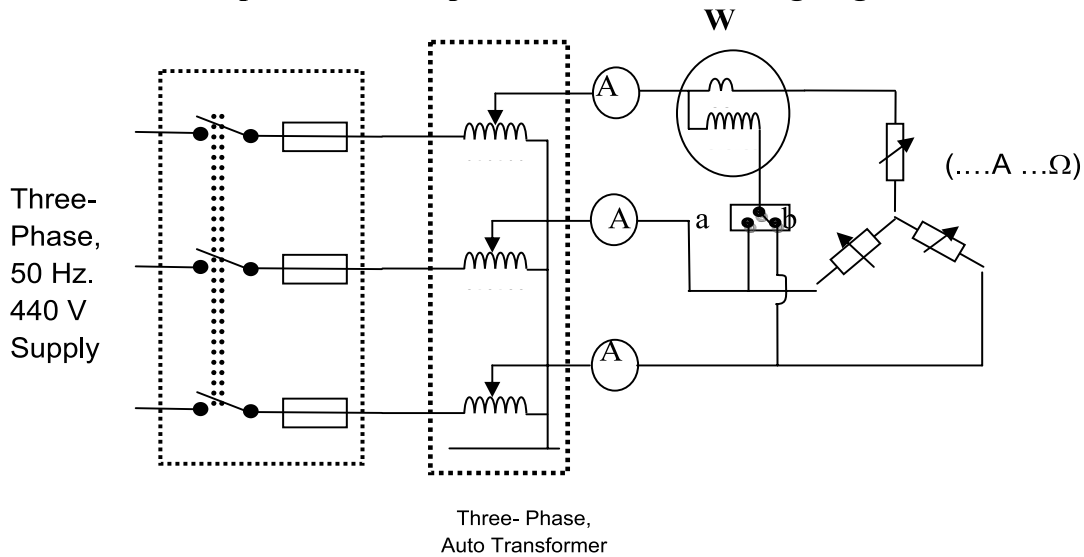

Figure 1:-Measurement of active power

2. Measure reactive power of three-phase balanced load using single wattmeter.

(To be drawn by student. Show ICTP, auto-transformer, ammeter, voltmeter, wattmeter and three phase balanced load in the circuit diagram with current coil in one phase and pressure coil across remaining two phases)

IX Resources Required

S. No.	Name of Resource	Suggested Broad Specification	Quantity
1	3-phase Auto transformer (Dimmerstat),	600V, 5 A	1 No.
2	Ammeter	0-5 A, MI	3 No.
3	Voltmeter	0- 600 V, MI	1 No.
4	Watt-meter	10A, 600 V, 2500 W	1 No.
5	Three phase resistive balanced load/ three rheostat	2.5kW,10A/5A,50 Ω	1No./3No.
6	Two way switch	5A,600V	1 No.

X Precautions to be Followed

- 1 Select proper range of meters.
- 2 Be careful while selecting AC/DC meters
- 3 Don't increase the current beyond meters capacity
- 4 Don't touch the live wire

XI Procedure

1. Measure active power of three-phase balanced load using single wattmeter.

1. Make the connections as per Figure 1.
2. Check and adjust zero indication of wattmeter and note the multiplying factor of wattmeter.
3. Switch on the supply.
4. Increase the output of dimmerstat up to rated voltage.
5. Adjust rheostats for equal currents through all ammeters.(Balanced load).
6. Note voltmeter, ammeter & wattmeter reading W_1 with switch at position 'a'.
7. Note wattmeter reading W_2 with the switch at position 'b'.
8. Take two readings for different current for balanced load.
9. Switch off the load and then the supply.
10. Calculate total active power and power factor.

2. Measure reactive power of three-phase balanced load using single wattmeter.

(Student should write the procedure)

.....

.....

.....

.....

.....

.....

.....

.....

.....

.....

XII Resources Used (Student should write the resources required)

S. No	Name of Resource	Broad Specifications		Quantity	Remarks (If any)
		Make	Details		
1.					
2.					
3.					
4.					
5.					

XIII Actual Procedure Followed (use blank sheet provided if space not sufficient)

.....

XIV Observations and Calculations (use blank sheet provided if space not sufficient)

1. Observations for measurement of active power.

$$\text{Multiplying factor} = \frac{\text{Voltage Range} \times \text{Current Range} \times \text{Rated Power Factor}}{\text{Full Scale Deflection}}$$

M.F. =

=

S.N	Ammeter reading I(Amp)	Voltmeter reading V (Volt)	Watt-meter reading x M.F. (Watt)		Total Active power P=W ₁ + W ₂ (Watt)	tan φ = [√3 (W ₁ - W ₂)/ (W ₁ + W ₂)]	φ = tan ⁻¹ φ	Power factor = Cos φ
			W ₁	W ₂				
1								
2								
3								
4								
5								

2.Observations for measurement of reactive power.

$$\text{Multiplying factor} = \frac{\text{Voltage Range} \times \text{Current Range} \times \text{Rated Power Factor}}{\text{Full Scale Deflection}}$$

M.F. =

=

S.N.	Ammeter reading I (Amp)	Voltmeter reading V (Volt)	Watt-meter reading x M.F. W (watt)	Total reactive power $Q=\sqrt{3} \times W$ (VAR)
1				
2				
3				
4				
5				

XV Results

.....

XVI Interpretation of Results (Give meaning of the above obtained results)

.....

XVII Conclusions (Actions/decisions to be taken based on the interpretation of results).

.....

XVIII Practical Related Questions (Note:-Teacher should provide various questions related to practical- sample given)

1. State the condition of balanced star connected load.
2. List four electrical equipment consuming reactive power.
3. Suggest suitable method to measure power consumed by a three phase induction motor used for pumping the water.

(Space for answers)

.....

Dotted lines for writing

XIX References / Suggestions for further reading

1. Experiments in Basic Electrical Engineering S.K.Bhattacharya K.M.Rastogi ISBN: 978-81-224-1041-6 New Age International Publications
2. <https://www.electrical4u.com/measurement-of-three-phase-power/>
3. Electrical Measurements and Measuring Instruments U. A. Bakshi, A. V. Bakshi K. A. Bakshi ISBN 9788184314380 First Edition – 2008 Technical Publications Pune

XX Suggested Assessment Scheme

Performance indicators		Weightage
Process related: 6 Marks		60%
1	Handling of the instruments	10 %
2	Identification of component/dial/scale	20 %
3	Measuring value using suitable instrument	20 %
4	Working in team	10 %
Product related: 4 Marks		40%
5	Writing result	10 %
6	Interpretation of result	05 %
7	Conclusions	05 %
8	Practical related questions	15 %
9	Submitting the journal in time	05%
Total (10 Marks)		100 %

Names of Student Team Members

1.
2.
3.

Marks Obtained			Dated signature of Teacher
Process Related(6)	Product Related(4)	Total (10)	

Practical No. 9: Troubleshoot Electrodynamic Watt-Meter

I Practical Significance

In the industry Electrical Engineering diploma graduate are expected to troubleshoot the wattmeter. Therefore this practical will help you to acquire necessary skills.

II Relevant Program Outcomes (POs)

- **Discipline knowledge:** Apply Electrical Engineering knowledge to solve broad based Electrical Engineering related problems.
- **Experiments and practice:** Plan to perform experiments and practices to use the results to solve broad-based Electrical Engineering problems.
- **Engineering tools:** Apply relevant Electrical technologies and tools with an understanding of the limitations.

III Competency and Practical Skills

This practical is expected to develop the following skills for the industry identified competency: **‘Use relevant measuring instrument in different electrical applications’**

- i. Use single phase wattmeter
- ii. Troubleshoot wattmeter

IV Relevant Course Outcome(s)

- Use wattmeter for electrical power measurement

V Practical Outcome

Troubleshoot electrodynamic watt-meter for measurement of power in a single phase circuit.

VI Relevant Affective domain related Outcome(s)

- a. Follow safety practices.
- b. Maintain tools and equipment.

VII Minimum Theoretical Background

In dynamometer type instrument deflecting torque is produced by magnetic effect of electrical current. Control torque is provided by control springs. Damping torque is provided by Air Friction Damping. In a dynamometer type wattmeter the fixed coil (current coil) is connected in series with the load. This coil is divided into two parts and they are kept parallel to each other. The coil is thick in cross section and has less number of turns.

The moving coil (pressure coil) is connected across the load. It is thin in cross-section and has hundreds of turns. It has a non-inductive high resistance in series with it.

VIII Practical set-up / Circuit diagram / Work Situation



Figure 1 Front view of wattmeter

IX Resources Required

S. No.	Name of Resource	Suggested Broad Specification	Quantity
1	Wattmeter	5A,300 V	1 No.
2	Voltmeter	0-300V	1 No.
3	Ammeter	0-5 A	1 No.
4	Single phase variac	4A,0-230 V	1 No.

X Precautions to be Followed

- 1 Select proper range of meters.
- 2 Be careful while selecting AC/DC meters
- 3 Don't increase the current beyond meters capacity
- 4 Don't touch the live wire

XI Problem Statement (to be provided by teacher, sample given here)

1. Wattmeter reads high
2. Wattmeter reads low

XII Procedure (Student should write the procedure)

.....

XIII Resources Used (Student should write the resources required)

S. No.	Name of Resource	Broad Specifications		Quantity	Remarks (If any)
		Make	Details		
1.					
2.					
3.					

XIV Actual Procedure Followed (use blank sheet provided if space not sufficient)

.....
.....
.....

XV Observations and Calculations (use blank sheet provided if space not sufficient)

- Student should observe the troubles, find the causes and provide the remedial action

.....
.....
.....
.....
.....

XVI Results

.....
.....
.....

XVII Interpretation of Results (Give meaning of the above obtained results)

.....
.....
.....

XVIII Conclusions (Actions/decisions to be taken based on the interpretation of results).

.....
.....
.....

XIX Practical Related Questions: (Note:-Teacher should provide various questions related to practical- sample given)

1. If capacitance effect exceeds than inductance effect in pressure coil, what will happen?
2. Wattmeter has weak operating field state the reason.

(Space for answers)

.....
.....
.....
.....
.....

A series of horizontal dotted lines providing a template for writing answers.

XX References / Suggestions for further reading

1. Experiments in Basic Electrical Engineering S.K.Bhattacharya K.M.Rastogi ISBN: 978-81-224-1041-6 New Age International Publications.
2. <https://en.wikipedia.org/wiki/Wattmeter>
3. Electrical Measurements and Measuring Instruments U. A. Bakshi A. V. Bakshi K. A. Bakshi ISBN 9788184314380 First Edition – 2008 Technical Publications Pune.

XXI Suggested Assessment Scheme

Performance indicators		Weightage
Process related: 6 Marks		60%
1	Handling of the instruments	10 %
2	Identification of component/dial/scale	20 %
3	Measuring value using suitable instrument	20 %
4	Working in team	10 %
Product related: 4 Marks		40%
5	Writing result	10 %
6	Interpretation of result	05 %
7	Conclusions	05 %
8	Practical related questions	15 %
9	Submitting the journal in time	05%
Total (10 Marks)		100 %

Names of Student Team Members

1.
2.
3.

Marks Obtained			Dated signature of Teacher
Process Related(6)	Product Related(4)	Total (10)	

Practical No. 10: Two Watt-Meters Method for Power Measurement

I Practical Significance

In the industry Electrical Engineering diploma graduate are expected to handle measuring instruments to measure power of 3-phase circuit using two wattmeter. Therefore this practical will help you to acquire necessary skills.

II Relevant Program Outcomes (POs)

- **Discipline knowledge:** Apply Electrical Engineering knowledge to solve broad based Electrical Engineering related problems.
- **Experiments and practice:** Plan to perform experiments and practices to use the results to solve broad-based Electrical Engineering problems.
- **Engineering tools:** Apply relevant Electrical technologies and tools with an understanding of the limitations.

III Competency and Practical Skills

This practical is expected to develop the following skills for the industry identified competency: **‘Use relevant measuring instrument in different electrical applications’**

- Measure active power using two wattmeter method
- Use wattmeter for power measurement

IV Relevant Course Outcome(s)

- Use wattmeter for electrical power measurement.

V Practical Outcome

Use two watt-meters for measuring active power of three-phase balanced load.

VI Relevant Affective domain related Outcome(s)

- a. Follow safety practices.
- b. Practice good housekeeping.
- c. Maintain tools and equipment.

VII Minimum Theoretical Background

Measurements of power in 3 phase circuit:

Two wattmeter method - This method is suitable for 3 phase, 3 wire system. It is commonly used method for star & delta system, balanced as well as unbalanced load.

Two wattmeter method:

In two wattmeter method, current coils of wattmeters are connected in any two lines. One terminal of each Pressure coil is connected to its own current coil & other terminal is connected to the third line as shown in the diagram.

For balanced as well as unbalanced load, the total active power is algebraic sum of the two wattmeter readings.

VIII Practical set-up / Circuit diagram / Work Situation

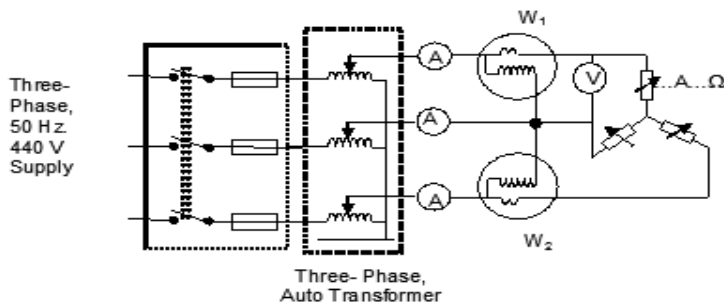

Figure 1: Measurement of power using two wattmeter

IX Resources Required

S. No.	Name of Resource	Suggested Specification	Broad	Quantity
1	3-phase Auto transformer (Dimmerstat)	600V, 5 A		1 No.
2	Ammeter	0-5 A, MI		3 No.
3	Voltmeter	0- 600 V, MI		1 No.
4	Watt-meter	10A, 600 V, 2500 W		1 No.
5	Rheostat	5A, 50 Ω		3No.
6	Three phase inductive load,	1 A, 440 V		1 No.
7	Three phase resistive load	5 A, 440 V		1 No.

X Precautions to be Followed

- 1 Select proper range of meters.
- 2 Be careful while selecting AC/DC meters
- 3 Don't increase the current beyond meters capacity
- 4 Don't touch the live wire

XI Procedure

1. Make the connections as per Figure 1.
2. Check zero indication of all meters & adjust if required
3. Note down multiplying factor of wattmeters.
4. Switch on the supply.
5. Increase the output voltage of three phase dimmerstat up to rated voltage.
6. Adjust balanced load condition.
7. Note readings of voltmeter, Ammeter & wattmeters
8. Take three / four readings by adjusting different currents for balanced load condition.
9. Calculate active power and power factor.

XII Resources Used (Student should write the resources required)

S. No.	Name of Resource	Broad Specifications		Quantity	Remarks (If any)
		Make	Details		
1.					
2.					
3.					
4.					
5.					

XIII Actual Procedure Followed (use blank sheet provided if space not sufficient)

.....

XIV Observations and Calculations (use blank sheet provided if space not sufficient)

1. Observations for measurement of active power.

Multiplying Factor for wattmeter (W₁):-

$$\text{Multiplying factor} = \frac{\text{Voltage Range} \times \text{Current Range} \times \text{Rated Power Factor}}{\text{Full Scale Deflection}}$$

M.F.=

Multiplying Factor for wattmeter (W₂):-

$$\text{Multiplying factor} = \frac{\text{Voltage Range} \times \text{Current Range} \times \text{Rated Power Factor}}{\text{Full Scale Deflection}}$$

M.F.=

S. N.	Type of load	Ammete r reading	Voltmeter reading	Watt-meter reading x M.F.	Watt-meter reading x M.F.	Total Active power
		I	V	W ₁	W ₂	W=W ₁ + W ₂
1	Pure Resistive					
2	Resistive + Inductive (i.e.inductive load)					

2. Calculations:

S.N.	Type of load	$\tan \phi$	ϕ	Power factor
		$= \sqrt{3} (W_1 - W_2) / (W_1 + W_2)$	$\tan^{-1} \phi$	$\cos \phi$
1	Pure Resistive			
2	Resistive + Inductive (i.e. inductive load)			

XV Results

.....

XVI Interpretation of Results (Give meaning of the above obtained results)

.....

XVII Conclusions (Actions/decisions to be taken based on the interpretation of results).

.....

XVIII Practical Related Questions (Note:-Teacher should provide various questions related to practical- sample given)

1. In three-phase balanced circuit, while measuring a power using two wattmeter, one wattmeter reads 2000 watts and other wattmeter reads 1500 watts respectively, Calculate the total active power and power factor of the load when i) both wattmeter readings are positive and ii) 1500 watt reading is obtained after reversing the pressure coil connection.
2. State what happen if pressure coil of one of the wattmeter is disconnected from the circuit

(Space for answers)

.....

XIX References / Suggestions for further reading

1. Experiments in Basic Electrical Engineering S.K.Bhattacharya K.M.Rastogi ISBN: 978-81-224-1041-6 New Age International Publications
2. <https://circuitglobe.com/two-wattmeter-method-of-power-measurement.html>
3. Electrical Measurements and Measuring Instruments U. A. Bakshi, A. V. Bakshi, K. A. Bakshi ISBN 9788184314380 First Edition – 2008 Technical Publications Pune

XX Suggested Assessment Scheme

Performance indicators		Weightage
Process related: 6 Marks		60%
1	Handling of the instruments	10 %
2	Identification of component/dial/scale	20 %
3	Measuring value using suitable instrument	20 %
4	Working in team	10 %
Product related: 4 Marks		40%
5	Writing result	10 %
6	Interpretation of result	05 %
7	Conclusions	05 %
8	Practical related questions	15 %
9	Submitting the journal in time	05%
Total (10 Marks)		100 %

Names of Student Team Members

1.
2.
3.

Marks Obtained			Dated signature of Teacher
Process Related(6)	Product Related(4)	Total (10)	

Practical No. 11: Calibration of Single Phase Electronic Energy Meter

I Practical Significance

In the industry Electrical Engineering diploma graduate are expected to find errors if any in single phase energy meter by calibration. Therefore this practical will help you to acquire necessary skills.

II Relevant Program Outcomes (POs)

- **Discipline knowledge:** Apply Electrical Engineering knowledge to solve broad based Electrical Engineering related problems.
- **Experiments and practice:** Plan to perform experiments and practices to use the results to solve broad-based Electrical Engineering problems.
- **Engineering tools:** Apply relevant Electrical technologies and tools with an understanding of the limitations.

III Competency and Practical Skills

This practical is expected to develop the following skills for the industry identified competency: **‘Use relevant measuring instrument in different electrical applications’**

- Test single phase energy meter.
- Measure energy by using KWh meter.

IV Relevant Course Outcome(s)

- Use energy meter for electrical energy measurement.

V Practical Outcome

Calibrate single phase electronic energy meter by direct loading

VI Relevant Affective domain related Outcome(s)

- a. Follow safety practices.
- b. Maintain tools and equipment.

VII Minimum Theoretical Background

The energy meter may become inaccurate during its vigorous use due to various reasons.

It is necessary to calibrate the meter to determine and remove the errors so that same meter can be used for correct measurement of energy.

An electricity meter, electric meter, electrical meter, or energy meter is a device that measures the amount of electric energy consumed by a consumer.

Electronic meters display the energy used on an LCD or LED display and some can also transmit readings to remote places. In addition to measuring energy used, electronic meters can also record other parameters of the load and supply such as instantaneous and maximum rate of usage demands, voltages, power factor and reactive power used etc. They can also support time-of-day billing, for example, recording the amount of energy used during on-peak and off-peak hours

Pulse Rate of Electronic Energy Meter (EEM)-

The pulse rate of EEM is calculated by counting the blinking of LED. Usual pulse rates of EEMs are 800 to 3600 pulses or impulses/ kWh. For most EEMs the pulse rate is 3200. It means that if 1000 Watt of power is consumed for 1 Hour the LED will blink 3200 times.

VIII Practical set-up / Circuit diagram / Work Situation

Figure 1: Front View of clamp-on meter

Circuit diagram:-

Figure 2: Calibration of EEM

IX Resources Required

S. No.	Name of Resource	Suggested Broad Specification	Quantity
1	Ammeter	0-10 A, MI	1 No.
2	Voltmeter	0-300 V, MI	1 No.
3	Wattmeter	10A ,300V	1 No.
4	Single phase electronics energy meter	Single phase, Two wire, 240 VoHz, 50 Hz, 10-60 Amps, Class-I, 800 imp/kWh	1 No.
5	Resistive load/lamp load	5 kW/Lamp Load	1 No.
6	Stop watch	Digital/analog	1 No.
7	Single phase variac	10A,0-270V	1 No.

X Precautions to be Followed

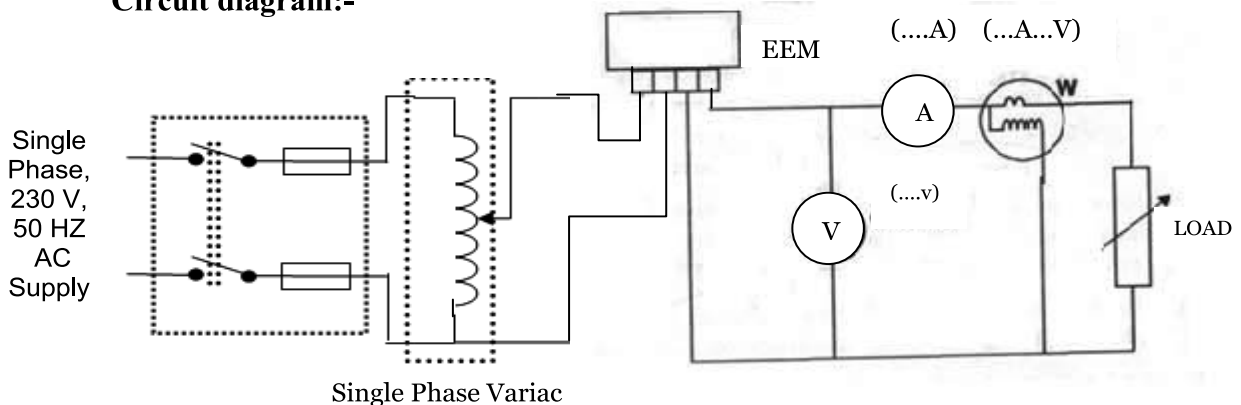
- 1 Select proper range of meters.
- 2 Be careful while selecting AC/DC meters.
- 3 Don't increase the current beyond meters capacity.
- 4 Don't touch the live wire.
- 5 Use auto-transformer for safety reason.

XI Procedure

1. Make the connections as per Figure 2.
2. Check and adjust zero indication of wattmeter and note the multiplying factor of wattmeter.
3. Initially keep dimmerstat at minimum position.
4. Keep all the switches of load bank at off position.
5. Switch on the supply.
6. Increase the output voltage of the dimmerstat gradually to rated voltage.
7. Switch on the switches of load bank step by step (say up to 500/1000 watts).
8. Count the pulses and time required using stop watch.
9. Record the reading in observation table.
10. Note voltmeter, ammeter & wattmeter reading.
11. Take another two readings for different load. (Say 1000 watts, 1500 Watts)
12. Switch off the supply.
13. Calculate % error of EEM.

XII Resources Used (Student should write the resources required)

S. No	Name of Resource	Broad Specifications		Quantity	Remarks (If any)
		Make	Details		
1.					
2.					
3.					
4.					
5.					

XIII Actual Procedure Followed (use blank sheet provided if space not sufficient)

.....

.....

.....

.....

.....

XIV Observations and Calculations (use blank sheet provided if space not sufficient)

Multipling Factor for wattmeter-W

$$\text{Multipling factor} = \frac{\text{Voltage Range} \times \text{Current Range} \times \text{Rated Power Factor}}{\text{Full Scale Deflection}}$$

M.F. = -----

= -----

SN	Ammeter Reading	Voltmeter Reading	Wattmeter Reading × MF	Number of pulses	Times in seconds
	I	V	W	P	t
1					
2					
3					
4					

Sample Calculations:

Number of pulses per kwh of EEM = -----
 (As mentioned on front panel of Electronics Energy Meter)

S. No	Energy recorded by EEM(Er) KWh	Calculated Energy (Ea) KWh	% Error	Mean % Error
	= Number of pulses /Number of pulses per kwh	$= (W \times t) / (3600 \times 10^3)$	$= ((Er - Ea) / Ea) \times 100$	
1				
2				
3				

XV Results

.....

XVI Interpretation of Results (Give meaning of the above obtained results)

.....

XVII Conclusions (Actions/decisions to be taken based on the interpretation of results).

.....

XVIII Practical Related Questions (Note:Teacher should provide various questions related to practical- sample given)

1. A single phase electronics energy meter has a constant of 3200 pulses/kwh. A test was carried out with a resistive load for one minute, during which meter gives 60 pulses. The voltage and current was 220 Volts and 5 ampere respectively. Calculate the percentage error.
2. State the meaning of positive percentage error and negative percentage error of an energy meter.

.....

.....

.....

.....

.....

XIX References / Suggestions for further reading

1. Experiments in Basic Electrical Engineering S.K.Bhattacharya K.M.Rastogi ISBN: 978-81-224-1041-6 New Age International Publications
2. <https://www.electrical4u.com/construction-of-ac-energy-meter>
3. https://en.wikipedia.org/wiki/Electricity_meter
4. Electrical Measurements and Measuring Instruments U. A. Bakshi A. V. Bakshi K. A. Bakshi ISBN 9788184314380 First Edition – 2008 Technical Publications Pune

XX Suggested Assessment Scheme

Performance indicators		Weightage
Process related: 6 Marks		60%
1	Handling of the instruments	10 %
2	Identification of component/dial/scale	20 %
3	Measuring value using suitable instrument	20 %
4	Working in team	10 %
Product related: 4 Marks		40%
5	Writing result	10 %
6	Interpretation of result	05 %
7	Conclusions	05 %
8	Practical related questions	15 %
9	Submitting the journal in time	05%
Total (10 Marks)		100 %

Names of Student Team Members

1.
2.
3.

Marks Obtained			Dated signature of Teacher
Process Related(6)	Product Related(4)	Total (10)	

Practical No. 12: Troubleshoot Electronic Energy Meter

I Practical Significance

In the industry Electrical Engineering diploma graduate are expected to troubleshoot the energy meter. Therefore this practical will help you to acquire necessary skills.

II Relevant Program Outcomes (POs)

- **Discipline knowledge:** Apply Electrical Engineering knowledge to solve broad based Electrical Engineering related problems.
- **Experiments and practice:** Plan to perform experiments and practices to use the results to solve broad-based Electrical Engineering problems.
- **Engineering tools:** Apply relevant Electrical technologies and tools with an understanding of the limitations.

III Competency and Practical Skills

This practical is expected to develop the following skills for the industry identified competency: **‘Use relevant measuring instrument in different electrical applications’**

- Troubleshoot Energy Meter

IV Relevant Course Outcome(s)

Use energy meter for electrical energy measurement

V Practical Outcome

Troubleshoot single phase electronic energy meter

VI Relevant Affective domain related Outcome(s)

- a. Follow safety practices.
- b. Practice good housekeeping.
- c. Maintain tools and equipment

VII Minimum Theoretical Background

The conventional mechanical energy meter is based on the phenomenon of “Magnetic Induction”. It has a rotating Aluminium disc. Based on the flow of current, the disc rotates which makes rotation of other wheels. This will be converted into corresponding measurements in the display section. Since many mechanical parts are involved, mechanical defects and breakdown are common. More over chances of manipulation and current theft will be higher.

Electronic Energy Meter is based on Digital Micro Technology (DMT) and uses no moving parts. So the EEM is known as “Static Energy Meter” In EEM the accurate functioning is controlled by a specially designed IC called ASIC (Application Specified Integrated Circuit).

VIII Practical set-up / Circuit diagram / Work Situation



Figure 1 Front view of Electronic Energy Meter

IX Resources Required

S. No.	Name of Resource	Suggested Broad Specification	Quantity
1	Single phase Electronic Energy Meter	230 V,5-30 Amp	1 No.
2	Test Lamp	100 W, 230 V	1 No.

X Precautions to be Followed

- Don't touch the live wire

XI Problem Statement (to be provided by teacher, sample given here)

1. Supply LED on meter front panel not blows
2. Meter runs slow i.e. number of pulses counts are less

XII Procedure (student should write the procedure)

.....

XIII Resources Used (student should write the resources required)

S. No.	Name of Resource	Broad Specifications		Quantity	Remarks (If any)
		Make	Details		
1.					
2.					
3.					

XIV Actual Procedure Followed (use blank sheet provided if space not sufficient)

.....
.....
.....

XV Observations and Calculations (use blank sheet provided if space not sufficient)

Student should observe the troubles, find the causes and provide the remedial action

XVI Results

.....
.....
.....

XVII Interpretation of Results (Give meaning of the above obtained results)

.....
.....
.....

XVIII Conclusions (Actions/decisions to be taken based on the interpretation of results).

.....
.....
.....

XIX Practical Related Questions: (Note:-Teacher should provide various questions related to practical- sample given)

1. State the reason for electricity bills getting inflated after replacement of old Electromechanical meters by new electronic meters by the utilities.
2. Give the reason for earth LED of energy meter glows

(Space for answers)

.....
.....
.....
.....
.....
.....
.....
.....
.....
.....
.....

.....

.....

.....

.....

.....

.....

XX References / Suggestions for further reading

1. Experiments in Basic Electrical Engineering S.K.Bhattacharya K.M.Rastogi ISBN: 978-81-224-1041-6 New Age International Publications
2. www.electrical4u.com
3. Electrical Measurements and Measuring Instruments U. A. Bakshi A. V. Bakshi K. A. Bakshi ISBN 9788184314380 First Edition – 2008 Technical Publications Pune

XXI Suggested Assessment Scheme

Performance indicators		Weightage
Process related: 6 Marks		60%
1	Handling of the instruments	10 %
2	Identification of component/dial/scale	20 %
3	Measuring value using suitable instrument	20 %
4	Working in team	10 %
Product related: 4 Marks		40%
5	Writing result	10 %
6	Interpretation of result	05 %
7	Conclusions	05 %
8	Practical related questions	15 %
9	Submitting the journal in time	05%
Total (10 Marks)		100 %

Names of Student Team Members

1.
2.
3.

Marks Obtained			Dated signature of Teacher
Process Related(6)	Product Related(4)	Total (10)	

Practical No. 13: Digital Multi-Meter

I Practical Significance

In the industry Electrical Engineering diploma graduate are expected to use digital multimeter to measure AC/DC current, AC/DC voltage. Therefore this practical will help you to acquire necessary skills.

II Relevant Program Outcomes (POs)

- **Discipline knowledge:** Apply Electrical engineering knowledge to solve broad based Electrical Engineering related problems.
- **Experiments and practice:** Plan to perform experiments and practices to use the results to solve broad-based Electrical engineering problems.
- **Engineering tools:** Apply relevant Electrical technologies and tools with an understanding of the limitations.

III Competency and Practical Skills

This practical is expected to develop the following skills for the industry identified competency: **‘Use relevant measuring instrument in different electrical applications’**

- Use digital multimeter.
- Measure various electrical parameters.

IV Relevant Course Outcome(s)

- Use measuring instruments.

V Practical Outcome

Use digital multi-meter for measurement of AC/DC current, AC/DC voltage

VI Relevant Affective domain related Outcome(s)

- Follow safety practices.
- Practice good housekeeping.
- Maintain tools and equipment

VII Minimum Theoretical Background

Multi-meter is a portable multi range instrument used for measurement of current, voltage and resistance. Basically multi-meters are of two types analog and digital.

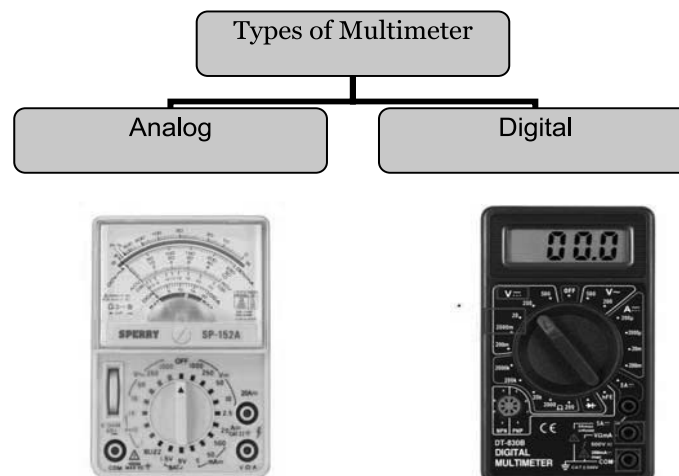

Front panel of digital multi-meter consists of Digital display panel, selector (rotary) switch, common input connector, V, Ω input connector, DC current input connector. Some DMM provides special functions for transistor and diode test, power measurement and decibel measurement

VIII Practical set-up / Circuit diagram / Work Situation

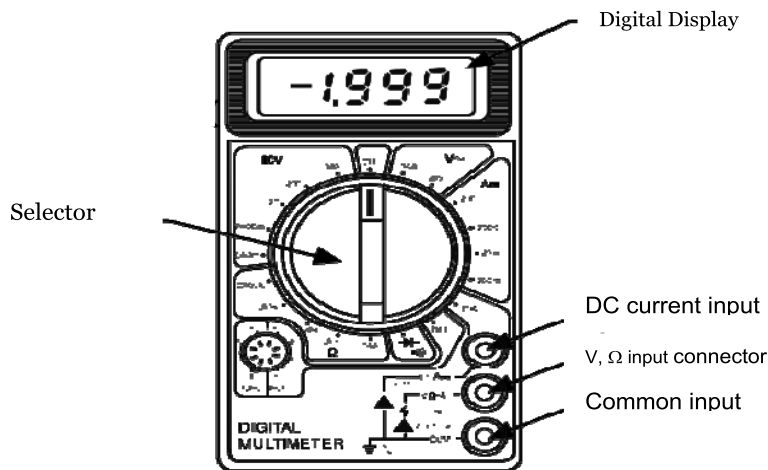

Figure 1 Front view of Digital Multi-meter

Circuit Diagram:

a) Measurement of AC current.

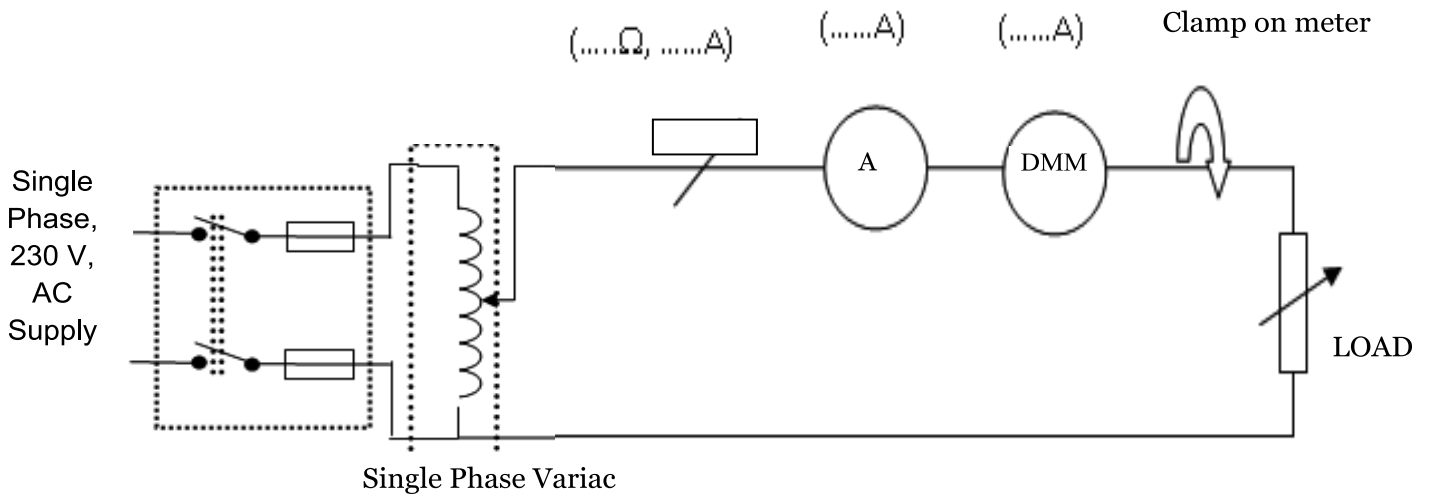

Figure 2: Measurement of AC current

b) Measurement of AC voltage

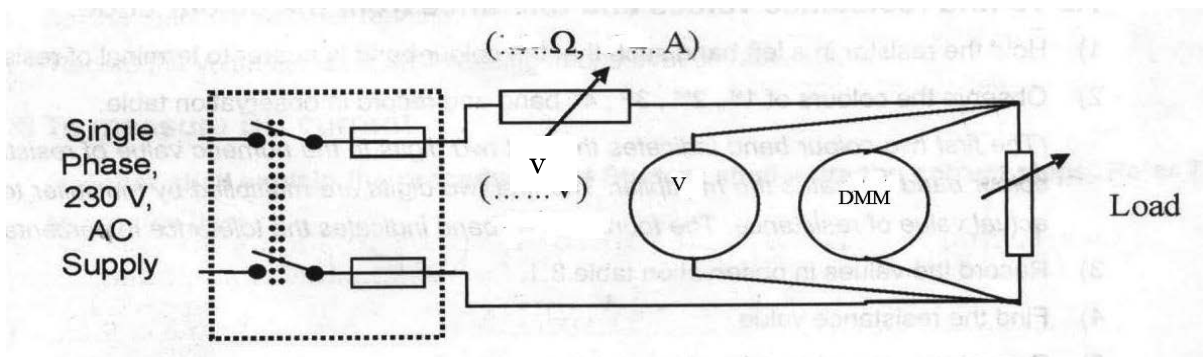

Figure 3: Measurement of AC voltage

c) Measurement of DC voltage (Circuit diagram to be drawn by student)

(Space for circuit diagram)

d) Measurement of DC voltage (Circuit diagram to be drawn by student)

(Space for circuit diagram)

IX Resources Required

S. No.	Name of Resource	Suggested Broad Specification	Quantity
1	Digital Multi-meter	Voltage: DC: 600 volts; AC: 600 volts, Current: DC: 20 amps; AC: 20 amps	1 No.
2	Analog ammeters	(0-5A) and (0-10A) AC,(0-5A) DC	1 No.
3	Analog voltmeter	(0-300V)	1 No.
4	Load 5 kW/Lamp Load	5 kW/Lamp Load	1 No.
5	Rheostat	0-270 V, 5A	1 No.

X Precautions to be Followed

- 1 Select proper range of meters.
- 2 Be careful while selecting AC/DC meters
- 3 Don't increase the current beyond meters capacity
- 4 Use auto-transformer for voltage variation in AC
- 5 Don't touch the live wire

XI Procedure**a) AC Current Measurement**

1. Connect a circuit as shown in Figure 2 for measurement of AC current.
2. Switch ON the supply.
3. Keep dimmerstat at minimum position.
4. Increase the output voltage of dimmerstat up to the rated value.
5. Switch on the load bank switches gradually in steps.
6. Record the current in the observation table after measuring with the DMM.
7. Record the ammeter reading.
8. Compare the reading of conventional Measuring instrument with DMM reading.
9. Increase the load by putting on one more switch of the load bank.
10. Repeat steps 6-9 four times.

b) AC Voltage Measurement

1. Connect a circuit as shown in Figure 3 for measurement of AC voltage.
2. Switch on the supply.
3. Keep dimmerstat at minimum position.
4. Increase the output voltage of dimmerstat up to rated value.
5. Switch on the load bank switches gradually in steps.
6. Set the DMM at correct AC voltmeter measuring mode by operating selector switch.
7. Insert the probes of DMM at proper input connector places.
8. Record the voltmeter and DMM reading in observation table
9. Increase the load by putting on one more switch of the load bank.
10. Repeat steps 8-9 four times.

c) DC Current Measurement (use separate sheet if space is not sufficient)

.....

d) DC Voltage Measurement (Student should write the procedure)

.....

XII Resources Used (student should write the required resources)

S. No.	Name of Resource	Broad Specifications		Quantity	Remarks (If any)
		Make	Details		
1.					
2.					
3.					

XIII Actual Procedure Followed (use blank sheet provided if space not sufficient)

.....

XIV Observations and Calculations (use blank sheet provided if space not sufficient)

a) AC current Measurement

S.No.	Ammeter reading	DMM Reading
1		
2		
3		
4		

b) AC Voltage Measurement

S.No.	Ammeter reading	DMM Reading
1		
2		
3		
4		

c) DC Voltage Measurement

S.No.	Ammeter reading	DMM Reading
1		
2		
3		
4		

d) DC current Measurement

S.No.	Ammeter reading	DMM Reading
1		
2		
3		
4		

XV Results

.....

XVI Interpretation of Results (Give meaning of the above obtained results)

.....

XVII Conclusions (Actions/decisions to be taken based on the interpretation of results).

.....

XVIII Practical Related Questions: (Note:-Teacher should provide various questions related to practical- sample given)

1. State the precautions to be taken while using digital multi-meter.
2. State the procedure for continuity test using multi-meter.
3. State the procedure to measure resistance using DMM.

(Space for answers)

.....

.....

.....

.....

.....

.....

.....

.....

.....

.....

XIX References / Suggestions for further reading

1. Experiments in Basic Electrical Engineering S.K.Bhattacharya K.M.Rastogi ISBN: 978-81-224-1041-6 New Age International Publications
2. <https://www.electrical4u.com/digital-multimeter/>
3. Electrical Measurements and Measuring Instruments U. A. Bakshi, A. V. Bakshi K. A. Bakshi ISBN 9788184314380 First Edition – 2008 Technical Publications Pune

XX Suggested Assessment Scheme

Performance indicators		Weightage
Process related: 6 Marks		60%
1	Handling of the instruments	10 %
2	Identification of component/dial/scale	20 %
3	Measuring value using suitable instrument	20 %
4	Working in team	10 %
Product related: 4 Marks		40%
5	Writing result	10 %
6	Interpretation of result	05 %
7	Conclusions	05 %
8	Practical related questions	15 %
9	Submitting the journal in time	05%
Total (10 Marks)		100 %

Names of Student Team Members

1.
2.
3.

Marks Obtained			Dated signature of Teacher
Process Related(6)	Product Related(4)	Total (10)	

Practical No. 14: Kelvin's Double Bridge

I Practical Significance

In the industry Electrical Engineering diploma graduate are expected to measure low resistance using Kelvin's double bridge. Therefore this practical will help you to acquire necessary skills.

II Relevant Program Outcomes (POs)

- **Discipline knowledge:** Apply Electrical Engineering knowledge to solve broad based Electrical Engineering related problems.
- **Experiments and practice:** Plan to perform experiments and practices to use the results to solve broad-based Electrical Engineering problems.
- **Engineering tools:** Apply relevant Electrical technologies and tools with an understanding of the limitations.

III Competency and Practical Skills

This practical is expected to develop the following skills for the industry identified competency: **'Use relevant measuring instrument in different electrical applications'**

- i. Use Kelvin Double Bridge.
- ii. Measure low resistance.

IV Relevant Course Outcome(s)

- a. Use measuring instruments.

V Practical Outcome

Use Kelvin's double bridge for measurement of low resistance.

VI Relevant Affective domain related Outcome(s)

- a. Follow safety practices.
- b. Practice good housekeeping.
- c. Demonstrate working as a leader/a team member.
- d. Maintain tools and equipment.

VII Minimum Theoretical Background

A Kelvin bridge also called a Kelvin double bridge and in some countries a Thomson bridge, is a measuring instrument used to measure unknown electrical resistors below 1 ohm. It is specifically designed to measure resistors that are constructed as four terminal resistors.

Use of Kelvin's Bridge eliminates the errors due to contact resistance and lead resistance. It also improves sensitivity. On the Kelvin's Bridge terminals are provided to connect current input, galvanometer and unknown resistance. A knob is provided for adjustment of the ratio of ' P/Q '. For balancing the bridge a variable standard resistance is used, which consists of a tapped resistance for coarse adjustment and slide wire resistance for fine adjustment.

Standard low resistance is constructed with four terminals. One pair of terminals is marked C, C called current terminals. The other pair is marked as P, P and is called as pressure terminals. The use of pressure terminals for measuring voltage across low resistance with four terminals eliminates error due to contact resistance and lead resistance.

VIII Practical set-up / Circuit diagram / Work Situation



Figure 1 Front view of Kelvin Double Bridge

Circuit Diagram:

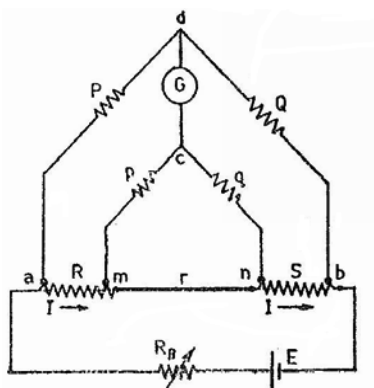

Figure 2 Kelvin Double Bridge

IX Resources Required

S. No.	Name of Resource	Suggested Broad Specification	Quantity
1	Kelvin's Double Bridge	Kit	1 No.
2	Battery Regulated DC supply	0-110 V	1 No.
3	Galvanometer	0-100 mA	1 No.
4	Unknown low resistance - Transformer windings/ Ammeter resistance.	Various low values resistance	1 No.

X Precautions to be Followed

- 1 Select proper range of meters.
- 2 Be careful while selecting AC/DC meters
- 3 Don't increase the current beyond meters capacity
- 4 Don't touch the live wire
- 5 There should not be any loose connections.

XI Procedure

1. Connect the circuit as per Figure 2
2. Connect the apparatus at the terminals indicated on Kelvin’s Bridge.
3. Select the proper range multiplier “ P/Q ”
4. Connect a rheostat in series with a battery or a low voltage supply to input terminals of the bridge.
5. Press the key of galvanometer. Vary the knob of main dial as per deflection of galvanometer for coarse adjustment. Use slide wire for fine adjustment. Take the reading when galvanometer shows null deflection.
6. Calculate the value of unknown resistance using given formula.
7. Switch off the supply.
8. Using reversing switch on bridge, reverse the direction of current.
9. Switch on the supply.
10. Repeat above procedure.
11. Calculate value of resistance in each case and find the mean from above two readings.
12. Replace the given low resistance by another resistance and repeat the same procedure.

XII Resources Used (student should write the resources required)

S. No	Name of Resource	Broad Specifications		Quantity	Remarks (If any)
		Make	Details		
1.					
2.					
3.					

XIII Actual Procedure Followed (use blank sheet provided if space not sufficient)

.....

XIV Observations and Calculations (use blank sheet provided if space not sufficient)

S.N.	P	Q	S	Calculated $R=(P/Q) \times S$
1				
2				
3				
4				

XV Results

.....

XVI Interpretation of Results (Give meaning of the above obtained results)

.....
.....
.....

XVII Conclusions (Actions/decisions to be taken based on the interpretation of results).

.....
.....
.....

XVIII Practical Related Questions: (Use separate sheet for answer)

(Teacher should provide various questions related to practical- sample given)

1. Kelvins Bridge is more suitable for measurement of low resistance. Give reason.
2. State the advantage of using four terminal resistances.

(Space for answers)

.....
.....
.....
.....
.....
.....
.....
.....
.....
.....
.....
.....
.....
.....
.....
.....
.....
.....
.....
.....
.....
.....

XIX References / Suggestions for further reading

1. Experiments in Basic Electrical Engineering S.K.Bhattacharya K.M.Rastogi ISBN: 978-81-224-1041-6 New Age International Publications
2. <https://www.electrical4u.com/kelvin-bridge-circuit-kelvin-double-bridge/>
3. https://en.wikipedia.org/wiki/Kelvin_bridge
4. Electrical Measurements and Measuring Instruments U. A. Bakshi A. V. Bakshi K. A. Bakshi ISBN 9788184314380 First Edition – 2008 Technical Publications Pune

XX Suggested Assessment Scheme

Performance indicators		Weightage
Process related: 6 Marks		60%
1	Handling of the instruments	10 %
2	Identification of component/dial/scale	20 %
3	Measuring value using suitable instrument	20 %
4	Working in team	10 %
Product related: 4 Marks		40%
5	Writing result	10 %
6	Interpretation of result	05 %
7	Conclusions	05 %
8	Practical related questions	15 %
9	Submitting the journal in time	05%
Total (10 Marks)		100 %

Names of Student Team Members

1.
2.
3.

Marks Obtained			Dated signature of Teacher
Process Related(6)	Product Related(4)	Total (10)	

Practical No.15: Measurement of medium resistance

I Practical Significance

In the industry Electrical Engineering diploma graduate are expected to measure medium resistance using voltmeter-ammeter method. Therefore this practical will help you to acquire necessary skills.

II Relevant Program Outcomes (POs)

- **Discipline knowledge:** Apply Electrical Engineering knowledge to solve broad based Electrical Engineering related problems.
- **Experiments and practice:** Plan to perform experiments and practices to use the results to solve broad-based Electrical Engineering problems.
- **Engineering tools:** Apply relevant Electrical technologies and tools with an understanding of the limitations.

III Competency and Practical Skills

This practical is expected to develop the following skills for the industry identified competency: ‘Use relevant measuring instrument in different electrical applications’

- i. Select relevant instruments.
- ii. Connect ammeter and voltmeter.
- iii. Read and record the reading
- iv. Calculate the unknown resistance.

IV Relevant Course Outcome(s)

- Use voltmeter and ammeter for electrical measurement

V Practical Outcome

- Use voltmeter and ammeter method for measurement of medium resistance

VI Relevant Affective domain related Outcome(s)

- a. Follow safety practices.
- b. Maintain tools and equipment.

VII Minimum Theoretical Background

The two types of connections employed for ammeter voltmeter method are shown in figure. In both the methods if readings of ammeter and voltmeter are taken then we can measure value of resistance by using formula:

$$R_M = \text{Voltmeter Reading} / \text{Ammeter Reading} = V/I \text{ Ohm}$$

The measured value of resistance R_m would be equal to the true value R , if the ammeter resistance is zero and the voltmeter resistance is infinite, so that the conditions in the circuit are not disturbed. But in actual practice this is not possible.

In first method when voltmeter is connected across supply side and readings are taken for a given unknown medium resistance, then the true value of resistance(R) is given by:-

$$R = R_M - R_A$$

Where R_M = Measured value of resistance and R_A = Resistance of Ammeter.

In second method when voltmeter is connected across unknown resistance side and readings are taken for a given unknown medium resistance, then the true value of resistance(R) is given by:-

$$R = R_M R_V / (R_V - R_M)$$

Where R_M = Measured value of resistance and R_V = Resistance of Voltmeter.

VIII Practical set-up / Circuit diagram / Work Situation

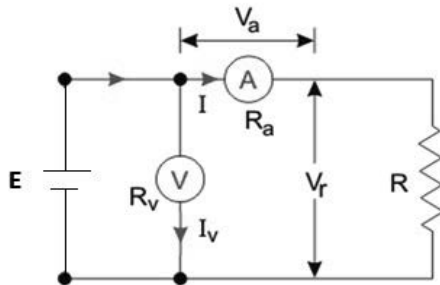

Figure-1

$$V = V_a + V_r$$

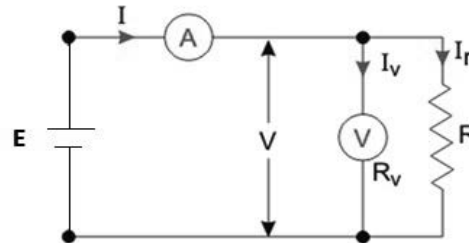

Figure-2

$$I = I_r + I_v$$

IX Resources Required

S. No.	Name of Resource	Suggested Broad Specification	Quantity
1	EMF Source	Variable Voltage Source.	1 No.
2	Voltmeter	Range (0-110/230V) with accuracy class 1.0.	1 No.
3	Ammeter	Range (0 to 5A) with accuracy class 1.0.	1 No.
4	Heater Coil	500 Watt or 1000 Watt	1 No.
5	Rheostat	1.2 A, 600 Ohm	1 No.

X Precautions to be Followed

- 1 The meter selected should be of accuracy class of 1.0
- 2 The reading must be taken and noted down carefully.
- 3 The internal resistance value of meter should be noted carefully from specification /Name plate of them.
- 4 Check and adjust zero setting of meters

XI Procedure

- 1) Make connections as per circuit diagram shown in figure 1.
- 2) Set the DC voltage to around 50 volt and switch on the supply.
- 3) Take readings of Voltmeter and Ammeter.
- 4) Switch off the supply and calculate measured value of unknown resistance and its true value.
- 5) Make connections as per circuit diagram shown in figure 2.
- 6) Set the DC voltage to around 50 volt and switch on the supply.
- 7) Take readings of Voltmeter and Ammeter.

- 8) Switch off the supply and calculate measured value of unknown resistance and its true value.

XII Resources Used (student should write the resources required)

S. No	Name of Resource	Broad Specifications		Quantity	Remarks (If any)
		Make	Details		
1.					
2.					
3.					

XIII Actual Procedure Followed (use blank sheet provided if space not sufficient)

.....

XIV Observations and Calculations (use blank sheet provided if space not sufficient)

A) When voltmeter is on supply side:-

Sr. No.	Voltmeter Reading(Volt)	Ammeter Reading (Amp)	Measured Unknown Resistance (Ohm)	True value of Unknown Resistance (Ohm)
1				
2				
3				

B) When voltmeter is on Resistance side:-

Sr. No.	Voltmeter Reading(Volt)	Ammeter Reading (Amp)	Measured Unknown Resistance (Ohm)	True value of Unknown Resistance (Ohm)
1				
2				
3				

Sample Calculations:

For Observation Table-A:-

- $R_M = \text{Voltmeter Reading} / \text{Ammeter Reading} = V/I = \dots\dots\text{Ohm}$
- $R = R_M - R_A = \dots\dots\dots\text{Ohm}$
 Where R_M = Measured value of resistance and R_A = Resistance of Ammeter.

For Observation Table-B:-

1) $R_M = \text{Voltmeter Reading}/\text{Ammeter Reading} = V/I = \dots\dots\dots\text{Ohm}$

2) $R = R_M R_V / (R_V - R_M) = \dots\dots\dots\text{Ohm}$

Where R_M = Measured value of resistance and R_V = Resistance of Voltmeter.

XV Results

.....
.....
.....

XVI Interpretation of Results (Give meaning of the above obtained results)

.....
.....
.....

XVII Conclusions (Actions/decisions to be taken based on the interpretation of results).

.....
.....
.....

XVIII Practical Related Questions: (Note:-Teacher should provide various questions related to practical- sample given)

1. The meters used should have high accuracy in this experiment? Give reason.
2. Can we measure resistance value of 100 Watt, 230 Volt Incandescent lamp by this method?
3. List methods suitable for measurement of medium resistance.

(Space for answers)

.....
.....
.....
.....
.....
.....
.....
.....
.....
.....

.....

.....

.....

.....

.....

.....

.....

.....

XIX References / Suggestions for further reading

1. Experiments in Basic Electrical Engineering S.K.Bhattacharya K.M.Rastogi ISBN: 978-81-224-1041-6 New Age International Publications
2. <https://www.electrical4u.com/measurement-of-resistance/>
3. Electrical Measurements and Measuring Instruments U. A. Bakshi A. V. Bakshi K. A. Bakshi ISBN 9788184314380 First Edition – 2008 Technical Publications Pune

XX Suggested Assessment Scheme

Performance indicators		Weightage
Process related: 6 Marks		60%
1	Handling of the instruments	10 %
2	Identification of component/dial/scale	20 %
3	Measuring value using suitable instrument	20 %
4	Working in team	10 %
Product related: 4 Marks		40%
5	Writing result	10 %
6	Interpretation of result	05 %
7	Conclusions	05 %
8	Practical related questions	15 %
9	Submitting the journal in time	05%
Total (10 Marks)		100 %

Names of Student Team Members

1.
2.
3.

Marks Obtained			Dated signature of Teacher
Process Related(6)	Product Related(4)	Total (10)	

Practical No. 16: Megger

I Practical Significance

In the industry Electrical Engineering diploma graduate are expected to use megger for measurement of insulation resistance of electrical equipments and electrical installation system. Therefore this practical will help you to acquire necessary skills.

II Relevant Program Outcomes (POs)

- **Discipline knowledge:** Apply Electrical Engineering knowledge to solve broad based Electrical Engineering related problems.
- **Experiments and practice:** Plan to perform experiments and practices to use the results to solve broad-based Electrical Engineering problems.
- **Engineering tools:** Apply relevant Electrical technologies and tools with an understanding of the limitations.

III Competency and Practical Skills

This practical is expected to develop the following skills for the industry identified competency: **‘Use relevant measuring instrument in different electrical applications’**

- Use Megger.
- Measure insulation resistance.

IV Relevant Course Outcome(s)

- Use measuring instruments.

V Practical Outcome

- Use Megger for insulation resistance measurements.

VI Relevant Affective domain related Outcome(s)

- Follow safety practices.
- Maintain tools and equipment.

VII Minimum Theoretical Background

Insulation resistance quality of an electrical system degrades with time, environment condition i.e. temperature, humidity, moisture and dust particles. It also get impacted negatively due to the presence of electrical and mechanical stress, so it becomes very necessary to check the IR (Insulation resistance) of equipment at a constant regular interval to avoid any major electrical shock.

Megger is an instrument designed, to measure extremely high value of resistance.

Megger measures the extremely high value of resistance, hence called mega-ohmmeter.

It is also used for measurement of insulation resistance, hence called insulation tester.

Figure 1 shows connection of megger for insulation resistance measurement

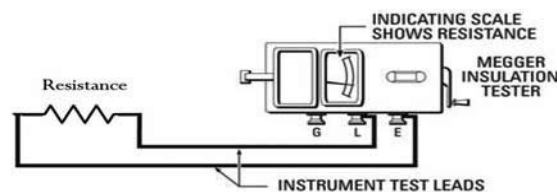

Figure 1

VIII Practical set-up / Circuit diagram / Work Situation

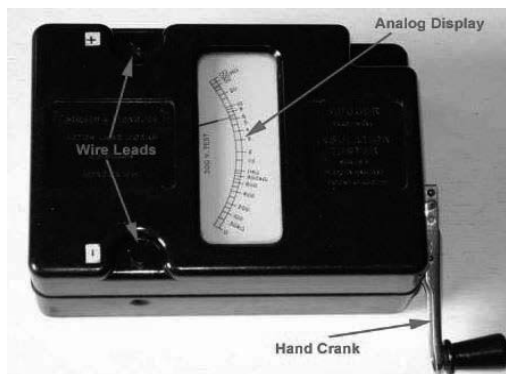

Figure 2 Front view of Megger

Connection Diagram:

1. Insulation resistance test between winding and frame of three-phase induction motor

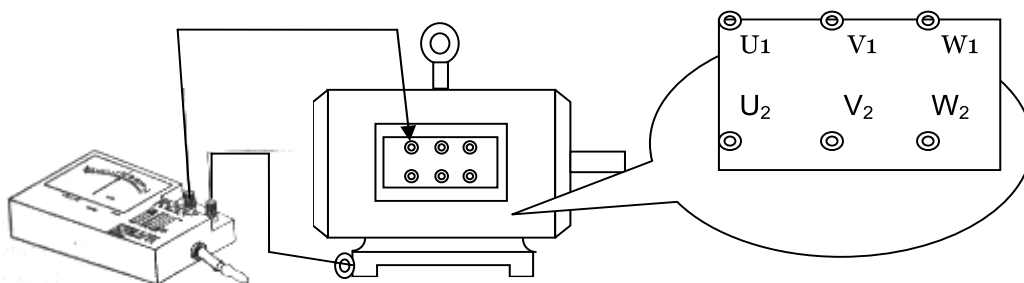

Figure 3: IR test between winding and frame

2. Students should draw the circuit for Insulation resistance measurement between windings of three-phase induction motor, DC machine and transformer.

(Space for connection diagram and use separate sheet if space is not sufficient)

IX Resources Required

S. No.	Name of Resource	Suggested Broad Specification	Quantity
1	Megger	500 V Hand Driven	1 No.

X Precautions to be Followed

1. The megger should not be used on live system.
2. The handle of the megger should be rotated in clockwise direction.
3. Don't touch the terminals of megger while conducting a test; otherwise it will give an electric shock.
4. Rotate the handle of megger at its rated speed.
5. Keep the megger in horizontal position while operation.

XI Procedure

1. Measure the insulation resistance between the winding and frame of three-phase induction motor.
 1. Connect the E terminal of megger to earth terminal (frame) motor.
 2. Connect the L terminal of megger to any one terminal of winding (say U_1)
 3. Rotate the handle of megger at its rated speed.
 4. Observe the reading.
 5. Note down the reading in observation table 1.
 6. Repeat the steps 2 to 5 for V and W windings.
2. Measure the insulation resistance between the winding of three-phase induction motor, DC machines and transformer. (Student should write the procedure)
(Use separate sheet)

XII Resources Used (Student should write the resources required)

S. No	Name of Resource	Broad Specifications		Quantity	Remarks (If any)
		Make	Details		
1.					
2.					
3.					

XIII Actual Procedure Followed (use blank sheet provided if space not sufficient)

.....

.....

.....

.....

XIV Observations and Calculations (use blank sheet provided if space not sufficient)

1. Observations for insulation test between winding and frame of three-phase induction motor.

S.N.	Between windings & Frame	Readings	Remarks
1.	U and frame		
2.	V and frame		
3.	W and frame		

2. Observations for insulation test between windings of three-phase induction motor.

S.N.	Between windings	Readings	Remarks
1.	U and W		
2.	U and V		
3.	V and W		

3. Observations for insulation test between windings of D.C. motor.

S.N.	Between windings	Readings	Remarks
1.	Armature and shunt field		
2.	Armature and series field		
3.	Series field and shunt field		

4. Observations for insulation test between windings of 3 phase Transformer

S.N.	Between windings	Readings	Remarks
1.	LV(r,y,b)-HV(R,Y,B)		
2.	LV of r(y,b) –LV of y(r,b)		
3.	HV of R(Y,B) –HV of Y(R,B)		

XV Results

.....

XVI Interpretation of Results (Give meaning of the above obtained results)

.....
.....
.....
.....
.....

XVII Conclusions (Actions/decisions to be taken based on the interpretation of results).

.....
.....
.....

XVIII Practical Related Questions: (Use separate sheet for answer)

(Teacher should provide various questions related to practical- sample given)

1. Does the cranking affect the megger reading
2. State the meaning of zero and infinity reading of megger.
3. State the procedure of measuring insulation resistance of residential installation.

(Space for answers)

.....
.....
.....
.....
.....
.....
.....
.....
.....
.....
.....
.....
.....
.....
.....
.....
.....
.....
.....
.....
.....
.....
.....
.....
.....
.....
.....
.....
.....
.....
.....
.....
.....
.....
.....
.....
.....
.....
.....
.....
.....
.....
.....
.....
.....
.....
.....
.....
.....

.....

.....

.....

.....

.....

.....

.....

XIX References / Suggestions for further reading

1. Experiments in Basic Electrical Engineering S.K.Bhattacharya K.M.Rastogi ISBN: 978-81-224-1041-6 New Age International Publications
2. <https://www.electrical4u.com/megger-working-principle-types-history-uses-of-megger/>
3. Electrical Measurements and Measuring Instruments U. A. Bakshi A. V. Bakshi K. A. Bakshi ISBN 9788184314380 First Edition – 2008 Technical Publications Pune

XX Suggested Assessment Scheme

Performance indicators		Weightage
Process related: 6 Marks		60%
1	Handling of the instruments	10 %
2	Identification of component/dial/scale	20 %
3	Measuring value using suitable instrument	20 %
4	Working in team	10 %
Product related: 4 Marks		40%
5	Writing result	10 %
6	Interpretation of result	05 %
7	Conclusions	05 %
8	Practical related questions	15 %
9	Submitting the journal in time	05%
Total (10 Marks)		100 %

Names of Student Team Members

1.
2.
3.

Marks Obtained			Dated signature of Teacher
Process Related(6)	Product Related(4)	Total (10)	

Practical No. 17: Earth Tester

I Practical Significance

In industries, substations, power stations and all electrical installations measurement of earth resistance with utmost accuracy and precision is an essential requirement. Electrical Engineering diploma graduate are expected to measure earth resistance using Earth Tester. Therefore this practical will help you to acquire necessary skills.

II Relevant Program Outcomes (POs)

- **Discipline knowledge:** Apply Electrical Engineering knowledge to solve broad based Electrical Engineering related problems.
- **Experiments and practice:** Plan to perform experiments and practices to use the results to solve broad-based Electrical Engineering problems.
- **Engineering tools:** Apply relevant Electrical technologies and tools with an understanding of the limitations.

III Competency and Practical Skills

This practical is expected to develop the following skills for the industry identified competency: **‘Use relevant measuring instrument in different electrical applications’**

- Use earth tester.
- Measure earth resistance.

IV Relevant Course Outcome(s)

- Use measuring instruments.

V Practical Outcome

- Use earth tester for measurement of earth resistance

VI Relevant Affective domain related Outcome(s)

- Follow safety practices.
- Maintain tools and equipment.

VII Minimum Theoretical Background

The earth tester is used to test the continuity of earthing system and measurement of the value of resistance offered by earthing system to the flow of leakage current. This works on the same principle as an Insulation Tester (Megger). It has a special form of ohm meter and supply source obtained through a hand driven generator. The current is rectified before it is applied to the moving coil ohm meter shown in Figure 1

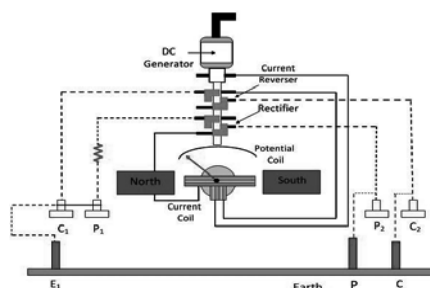

Figure 1: Internal structure of earth tester

VIII Practical set-up / Circuit diagram / Work Situation



Figure 2: Front view of Earth Tester

Connection Diagram:

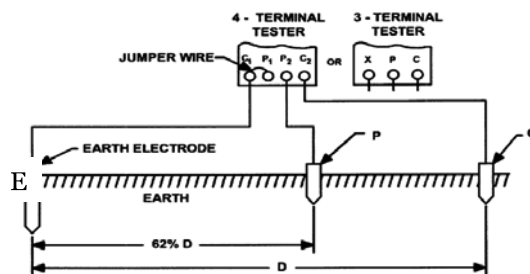

Figure 3: Earth resistance measurement

IX Resources Required

S. No.	Name of Resource	Suggested Broad Specification	Quantity
1	Earth Tester Digital/ Analog	0 - 10 ohm to 10000 ohm (Any one range)	1 No.
2	Hammer and Screw Driver	Standard	1 No. Each
3	Connecting Wire	Standard	50 mtr.
4	M.S.Spikes	Standard	3 No.

X Precautions to be Followed

1. Avoid loose connections.
2. Insert the spikes deeply more than half of total length of spike.
3. Don't use earth tester on live system

XI Procedure

1. Insert the spikes at suitable distance as mentioned in manual.
2. Short C_1 and P_1 terminals of earth tester.
3. Connect shorted terminals to earth electrode whose resistance is to be measured.
4. Connect terminal P_2 of earth tester to potential spike P
5. Connect terminal C_2 of earth tester to current spike C
6. Rotate the handle of earth tester with constant speed.
7. Note down reading and change the distance between spikes.

8. Note down readings for different position of spikes and draw a graph between earth resistance (on Y-axis) and distance between E and P spikes (on X-axis).

XII Resources Used (Student should write the resources required)

S. No	Name of Resource	Broad Specifications		Quantity	Remarks (If any)
		Make	Details		
1.					
2.					
3.					

XIII Actual Procedure Followed (use blank sheet provided if space not sufficient)

.....

XIV Observations and Calculations (use blank sheet provided if space not sufficient)

S.N.	Distance between E and P (meters)	Distance between P and C (meters)	Earth Resistance in Ohm.
1			
2			
3			
4			

XV Results

.....

XVI Interpretation of Results (Give meaning of the above obtained results)

.....

XVII Conclusions (Actions/decisions to be taken based on the interpretation of results).

.....

XVIII Practical Related Questions: (Note:- Teacher should provide various questions related to practical- sample given)

1. For a new building earthing is to be done but the soil at that place is having high resistance. State the different methods to reduce earth resistance
2. In electrical installations three terminals (Phase, Neutral and earth in three pin socket) are used. Out of these three, earth terminal is having larger cross section area compare to other two. State the reason for this.

3. Give the values of earth resistance of the power station, large sub-station, HT line, LT line and residential installation.

(Space for answers)

.....

.....

.....

.....

.....

.....

.....

.....

.....

.....

.....

.....

.....

.....

.....

.....

.....

.....

.....

.....

.....

.....

.....

.....

.....

.....

.....

.....

.....

.....

.....

.....

.....

.....

.....

.....

.....

.....

.....

.....

.....

.....

.....

.....

.....

.....

.....

.....

.....

.....

.....

.....

.....

.....

.....

.....

XIX References / Suggestions for further reading

1. Experiments in Basic Electrical Engineering S.K.Bhattacharya K.M.Rastogi ISBN: 978-81-224-1041-6 New Age International Publications
2. <https://www.electrical4u.com/earthing-of-substation-equipment/>
3. Electrical Measurements and Measuring Instruments U. A. Bakshi A. V. Bakshi K. A. Bakshi ISBN 9788184314380 First Edition – 2008 Technical Publications Pune

XX Suggested Assessment Scheme

Performance indicators		Weightage
Process related: 6 Marks		60%
1	Handling of the instruments	10 %
2	Identification of component/dial/scale	20 %
3	Measuring value using suitable instrument	20 %
4	Working in team	10 %
Product related: 4 Marks		40%
5	Writing result	10 %
6	Interpretation of result	05 %
7	Conclusions	05 %
8	Practical related questions	15 %
9	Submitting the journal in time	05%
Total (10 Marks)		100 %

Names of Student Team Members

1.
2.
3.

Marks Obtained			Dated signature of Teacher
Process Related(6)	Product Related(4)	Total (10)	

Practical No. 18: Frequency measurement by CRO

I Practical Significance

In the industry Electrical Engineering diploma graduate are expected to handle cathode ray oscilloscope (CRO) to measure basic parameters like voltage, frequency, and time period of supply systems. Therefore this practical will help you to acquire necessary skills.

II Relevant Program Outcomes (POs)

- **Discipline knowledge:** Apply Electrical Engineering knowledge to solve broad based Electrical Engineering related problems.
- **Experiments and practice:** Plan to perform experiments and practices to use the results to solve broad-based Electrical Engineering problems.
- **Engineering tools:** Apply relevant Electrical technologies and tools with an understanding of the limitations.

III Competency and Practical Skills

This practical is expected to develop the following skills for the industry identified competency ‘Use relevant measuring instrument in different electrical applications’

- Use CRO for measurement of supply frequency.

IV Relevant Course Outcome(s)

- Use measuring instruments.

V Practical Outcome

- Use CRO for the Measurement of supply frequency in single-phase circuit.

VI Relevant Affective domain related Outcome(s)

- Follow safety practices.
- Maintain tools and equipment.

VII Minimum Theoretical Background

CRO is an instrument used to measure electric parameter such as voltage, frequency, time period of given waveform like sinusoidal, triangular, square. CRO is also used to test various active and passive electrical components such as resistor, capacitor, and inductor.

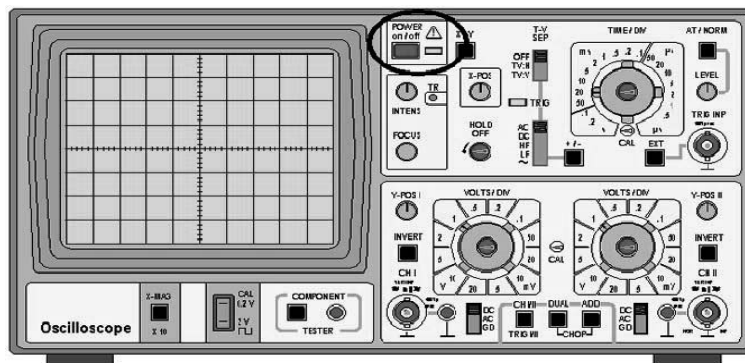

Figure 1 CRO Front Panel

VIII Practical set-up / Circuit diagram / Work Situation

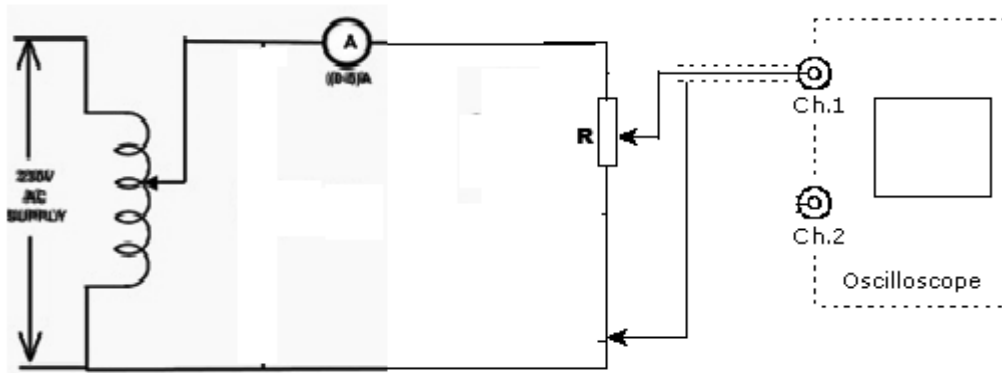

Figure 2 Connection Diagram to measure supply frequency by CRO

IX Resources Required

S. No.	Name of Resource	Suggested Broad Specification	Quantity
1	Rheostat	Suitable Rheostat(0-220ohm,5A)	1
2	CRO	20/30/100 MHz Frequency With attenuator probes	1

X Precautions to be Followed

1. Ensure proper earthing to the equipment.
2. Ensure the power switch is in 'off' condition initially.
3. Ensure that the CRO power switch is in off condition.
4. Ensure proper settings of CRO before use.

XI Procedure

1. Connect the circuit as per Figure 2.
2. Connect the CRO for observing voltage waveform of supply across the resistance.
3. The horizontal sweep is turned ON and the display appearing on the screen is adjusted by varying different control knobs provided on the front panel of CRO, till the signal is suitably displayed.
4. After obtaining the display of good deflection, count the number of horizontal division for a complete cycle to get the time period (T) of supply voltage. .
5. Calculate the frequency of supply by using equation :

$$f = 1/T \text{ Hz}$$

XII Resources Used (Student should write the resources required)

S. No	Name of Resource	Broad Specifications		Quantity	Remarks (If any)
		Make	Details		
1.					
2.					
3.					

XIII Actual Procedure Followed (use blank sheet provided if space not sufficient)

.....

XIV Observations and Calculations

Sr. No.	Number of Division in complete cycle(m)	Time per Division(n)	Time Period $T = m * n$ (seconds)	Frequency $f = 1/T$ (Hz)
1				
2				

XV Results

.....

XVI Interpretation of Results (Give meaning of the above obtained results)

.....

XVII Conclusions (Actions/decisions to be taken based on the interpretation of results).

.....

XVIII Practical Related Questions: (Note: Teacher should provide various questions related to practical- sample given)

1. State the test condition indicated if vertical line is observed on CRO.
2. State the need of proper earthing of CRO.
3. “Trace of the spot on the screen looks likes a continuous line”. Give reason.

(Space for answers)

.....

XIX References / Suggestions for further reading

1. Experiments in Basic Electrical Engineering S.K.Bhattacharya K.M.Rastogi ISBN: 978-81-224-1041-6 New Age International Publications
2. <https://www.electrical4u.com/measurement-of-voltage-current-and-frequency-by-oscilloscope/>
3. Electrical Measurements and Measuring Instruments U. A. Bakshi A. V. Bakshi K. A. Bakshi ISBN 9788184314380 First Edition – 2008 Technical Publications, Pune

XX Suggested Assessment Scheme

Performance indicators		Weightage
Process related: 6 Marks		60%
1	Handling of the instruments	10 %
2	Identification of component/dial/scale	20 %
3	Measuring value using suitable instrument	20 %
4	Working in team	10 %
Product related: 4 Marks		40%
5	Writing result	10 %
6	Interpretation of result	05 %
7	Conclusions	05 %
8	Practical related questions	15 %
9	Submitting the journal in time	05%
Total (10 Marks)		100 %

Names of Student Team Members

1.
2.
3.

Marks Obtained			Dated signature of Teacher
Process Related(6)	Product Related(4)	Total (10)	

Practical No. 19: Tri-Vector Meter.

I Practical Significance

In the industry Electrical Engineering diploma graduate are expected to use Tri-vector meter to measure various power (KW, KVAR and KVA) of electrical power systems. Therefore this practical will help you to acquire necessary skills.

II Relevant Program Outcomes (POs)

- **Discipline knowledge:** Apply Electrical Engineering knowledge to solve broad based Electrical Engineering related problems.
- **Experiments and practice:** Plan to perform experiments and practices to use the results to solve broad-based Electrical Engineering problems.
- **Engineering tools:** Apply relevant Electrical technologies and tools with an understanding of the limitations.

III Competency and Practical Skills

This practical is expected to develop the following skills for the industry identified competency ‘Use relevant measuring instrument in different electrical applications’

- i. Select relevant Tri-vector meter.
- ii. Measure various powers.

IV Relevant Course Outcome(s)

- a. Use measuring instruments.

V Practical Outcome

- Use Tri-vector meter for measuring KW, KVAR and KVA of a power line.

VI Relevant Affective domain related Outcome(s)

- a. Follow safety practices.
- b. Maintain tools and equipment.

VII Minimum Theoretical Background

The Trivector meter is a measuring instrument which measures the KW, KVAR and KVA of a power line. These instruments can measure both power as well as energy. Trivector meters are normally used in substations and to measure the power flowing through the feeders. They are also used for billing power drawn by industrial customers. The Trivector meter enables the simultaneous measurement of different electrical parameters which enables accurate power measurement. Since it measures three vectors representing the active, reactive and apparent power of a line therefore it is called as trivector meter. Trivector meters come in two quadrant and four quadrant models. The four quadrant model can measure both the incoming (import) and the outgoing power (export) while the two quadrant trivector meter can measure either imported or exported power.



Figure 1 Front Panel of Tri-Vector Meter

VIII Practical set-up / Circuit diagram / Work Situation (Sample Diagram)

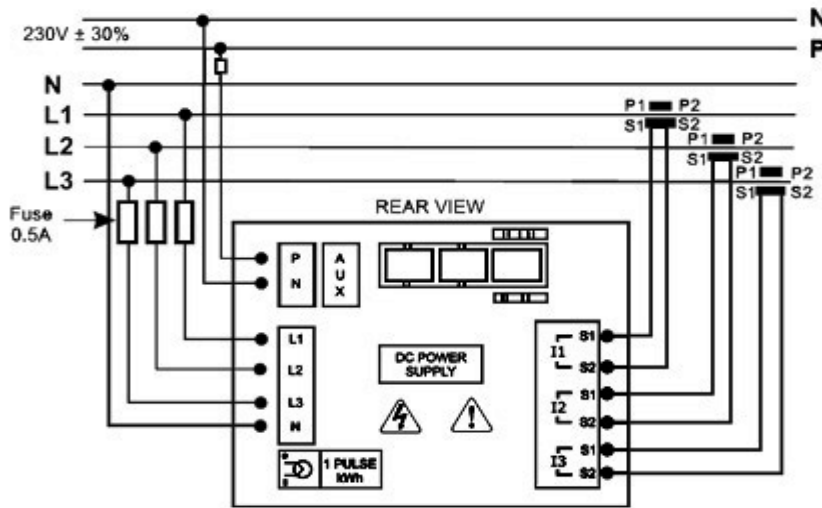

Figure 2 Connection Diagram for Power Measurement

IX Resources Required

S. No.	Name of Resource	Suggested Broad Specification	Quantity
1	Tri-Vector Meter	Suitable Three Phase, Four Wires, 100/5 Amps	1 No.
2	Load bank	415Volt,20Amp (R-L load)	1 No.

X Precautions to be Followed

1. Connection should be done as per circuit diagram provided on meter.
2. CT connection on secondary side should not open.
3. Auxiliary supply should be of single phase AC.

XI Procedure

1. Make connections as per circuit diagram mentioned on meter manual.
2. Use resistive load initially and take readings for different values of load.
3. Disconnect resistive load and then connect R-L load bank and take readings for different values of load.

XII Resources Used (Student should write the resources required)

S. No	Name of Resource	Broad Specifications		Quantity	Remarks (If any)
		Make	Details		
1.					
2.					
3.					

XIII Actual Procedure Followed (use blank sheet provided if space not sufficient)

.....

XIV Observations and Calculations (use blank sheet provided if space not sufficient)

Sr.No.	Active Power (kW)	Reactive Power (kVAR)	Apparent Power (kVA)	Power Factor
1				
2				
3				
4				

XV Results

.....

XVI Interpretation of Results (Give meaning of the above obtained results)

.....

XVII Conclusions (Actions/decisions to be taken based on the interpretation of results).

.....

XVIII Practical Related Questions

1. Explain why auxiliary supply is needed in Tri-vector meter?

XIX References / Suggestions for further reading

1. Experiments in Basic Electrical Engineering S.K.Bhattacharya K.M.Rastogi ISBN: 978-81-224-1041-6 New Age International Publications
2. <https://www.electrotechnik.net/2012/04/what-is-trivector-meter-where-is-it-used.html>
3. Electrical Measurements and Measuring Instruments U. A. Bakshi A. V. Bakshi K. A. Bakshi ISBN 9788184314380 First Edition – 2008 Technical Publications Pune

XX Suggested Assessment Scheme

Performance indicators		Weightage
Process related: 6 Marks		60%
1	Handling of the instruments	10 %
2	Identification of component/dial/scale	20 %
3	Measuring value using suitable instrument	20 %
4	Working in team	10 %
Product related: 4 Marks		40%
5	Writing result	10 %
6	Interpretation of result	05 %
7	Conclusions	05 %
8	Practical related questions	15 %
9	Submitting the journal in time	05%
Total (10 Marks)		100 %

Names of Student Team Members

1.
2.
3.

Marks Obtained			Dated signature of Teacher
Process Related(6)	Product Related(4)	Total (10)	

List Of Laboratory Manuals Developed by MSBTE

First Semester:

1	Fundamentals of ICT	22001
2	English	22101
3	English Work Book	22101
4	Basic Science (Chemistry)	22102
5	Basic Science (Physics)	22102

Second Semester:

1	Business Communication Using Computers	22009
2	Computer Peripherals & Hardware Maintenance	22013
3	Web Page Design with HTML	22014
4	Applied Science (Chemistry)	22202
5	Applied Science (Physics)	22202
6	Applied Machines	22203
7	Basic Surveying	22205
8	Applied Science (Chemistry)	22211
9	Applied Science (Physics)	22211
10	Fundamental of Electrical Engineering	22212
11	Elements of Electronics	22213
12	Elements of Electrical Engineering	22215
13	Basic Electronics	22216
14	'C' programming Language	22218
15	Basic Electronics	22225
16	Programming in "C"	22226
17	Fundamentals of Chemical Engineering	22231

Third Semester:

1	Applied Multimedia Techniques	22024
2	Advanced Surveying	22301
3	Highway Engineering	22302
4	Mechanics of Structures	22303
5	Building Construction	22304
6	Concrete Technology	22305
7	Strength Of Materials	22306
8	Automobile Engines	22308
9	Automobile Transmission System	22309
10	Mechanical Operations	22313
11	Technology Of Inorganic Chemicals	22314
12	Object Oriented Programming Using C++	22316
13	Data Structure Using 'C'	22317
14	Computer Graphics	22318
15	Database Management System	22319
16	Digital Techniques	22320
17	Principles Of Database	22321
18	Digital Techniques & Microprocessor	22323
19	Electrical Circuits	22324
20	Electrical & Electronic Measurement	22325
21	Fundamental Of Power Electronics	22326
22	Electrical Materials & Wiring Practice	22328
23	Applied Electronics	22329
24	Electrical Circuits & Networks	22330
25	Electronic Measurements & Instrumentation	22333
26	Principles Of Electronics Communication	22334
27	Thermal Engineering	22337
28	Engineering Metrology	22342
29	Mechanical Engineering Materials	22343
30	Theory Of Machines	22344

Fourth Semester:

1	Hydraulics	22401
2	Geo Technical Engineering	22404
3	Chemical Process Instrumentation & Control	22407
4	Fluid Flow Operation	22409
5	Technology Of Organic Chemicals	22410
6	Java Programming	22412
7	GUI Application Development Using VB.net	22034
8	Microprocessor	22415
9	Database Management	22416
10	Electric Motors And Transformers	22418
11	Industrial Measurements	22420
12	Digital Electronics And Microcontroller Applications	22421
13	Linear Integrated Circuits	22423
14	Microcontroller & Applications	22426
15	Basic Power Electronics	22427

16	Digital Communication Systems	22428
17	Mechanical Engineering Measurements	22443
18	Fluid Mechanics and Machinery	22445
19	Fundamentals Of Mechatronics	22048

Fifth Semester:

1	Design of Steel and RCC Structures	22502
2	Public Health Engineering	22504
3	Heat Transfer Operation	22510
4	Environmental Technology	22511
5	Operating Systems	22516
6	Advanced Java Programming	22517
7	Software Testing	22518
8	Control Systems and PLC's	22531
9	Embedded Systems	22532
10	Mobile and Wireless Communication	22533
11	Industrial Machines	22523
12	Switchgear and Protection	22524
13	Energy Conservation and Audit	22525
14	Power Engineering and Refrigeration	22562
15	Solid Modeling and Additive Manufacturing	22053
16	Guidelines & Assessment Manual for Micro Projects & Industrial Training	22057

Sixth Semester:

1	Solid Modeling	17063
2	Highway Engineering	17602
3	Contracts & Accounts	17603
4	Design of R.C.C. Structures	17604
5	Industrial Fluid Power	17608
6	Design of Machine Elements	17610
7	Automotive Electrical and Electronic Systems	17617
8	Vehicle Systems Maintenance	17618
9	Software Testing	17624
10	Advanced Java Programming	17625
11	Mobile Computing	17632
12	System Programming	17634
13	Testing & Maintenance of Electrical Equipments	17637
14	Power Electronics	17638
15	Illumination Engineering	17639
16	Power System Operation & Control	17643
17	Environmental Technology	17646
18	Mass Transfer Operation	17648
19	Advanced Communication System	17656
20	Mobile Communication	17657
21	Embedded System	17658
22	Process Control System	17663
23	Industrial Automation	17664
24	Industrial Drives	17667
25	Video Engineering	17668
26	Optical Fiber & Mobile Communication	17669
27	Therapeutic Equipment	17671
28	Intensive Care Equipment	17672
29	Medical Imaging Equipment	17673

Pharmacy Lab Manual

First Year:

1	Pharmaceutics - I	0805
2	Pharmaceutical Chemistry - I	0806
3	Pharmacognosy	0807
4	Biochemistry and Clinical Pathology	0808
5	Human Anatomy and Physiology	0809

Second Year:

1	Pharmaceutics - II	0811
2	Pharmaceutical Chemistry - II	0812
3	Pharmacology & Toxicology	0813
4	Hospital and Clinical Pharmacy	0816

HEAD OFFICE

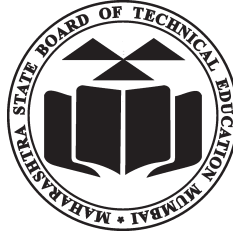

Secretary,

Maharashtra State Board of Technical Education

49, Kherwadi, Bandra (East), Mumbai - 400 051

Maharashtra (INDIA)

Tel: (022)26471255 (5 -lines)

Fax: 022 - 26473980

Email: -secretary@msbte.com

Web -www.msbte.org.in

REGIONAL OFFICES:

MUMBAI

Deputy Secretary (T),
Mumbai Sub-region,
2nd Floor, Govt. Polytechnic Building,
49, Kherwadi, Bandra (East)
Mumbai - 400 051
Phone: 022-26473253 / 54
Fax: 022-26478795
Email: rbtemumbai@msbte.com

PUNE

Deputy Secretary (T),
M.S. Board of Technical Education,
Regional Office,
412-E, Bahirat Patil Chowk,
Shivaji Nagar, Pune
Phone: 020-25656994 / 25660319
Fax: 020-25656994
Email: rbtepn@msbte.com

NAGPUR

Deputy Secretary (T),
M.S. Board of Technical Education
Regional Office,
Mangalwari Bazar, Sadar, Nagpur - 440 001
Phone: 0712-2564836 / 2562223
Fax: 0712-2560350
Email: rbteeng@msbte.com

AURANGABAD

Deputy Secretary (T),
M.S. Board of Technical Education,
Regional Office,
Osmanpura, Aurangabad -431 001.
Phone: 0240-2334025 / 2331273
Fax: 0240-2349669
Email: rbteau@msbte.com