

# I

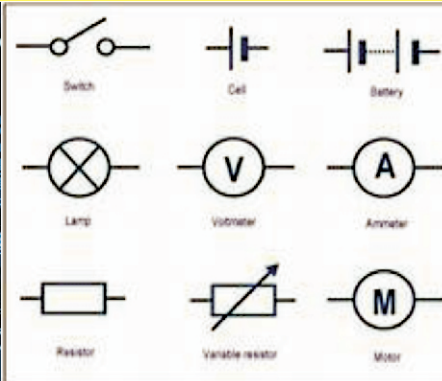
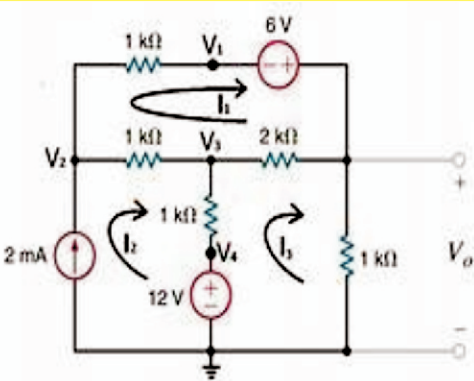
Name \_\_\_\_\_

Roll No. \_\_\_\_\_ Year 20\_\_\_\_ 20\_\_\_\_

Exam Seat No. \_\_\_\_\_

**ELECTRONICS GROUP | SEMESTER - III | DIPLOMA IN ENGINEERING AND TECHNOLOGY**

# A LABORATORY MANUAL FOR ELECTRIC CIRCUITS & NETWORKS (22330)



**MAHARASHTRA STATE BOARD OF TECHNICAL EDUCATION, MUMBAI**  
(Autonomous) (ISO 9001 : 2015) (ISO / IEC 27001 : 2013)

## **VISION**

To ensure that the Diploma level Technical Education constantly matches the latest requirements of technology and industry and includes the all-round personal development of students including social concerns and to become globally competitive, technology led organization.

## **MISSION**

To provide high quality technical and managerial manpower, information and consultancy services to the industry and community to enable the industry and community to face the changing technological and environmental challenges.

## **QUALITY POLICY**

We, at MSBTE are committed to offer the best in class academic services to the students and institutes to enhance the delight of industry and society. This will be achieved through continual improvement in management practices adopted in the process of curriculum design, development, implementation, evaluation and monitoring system along with adequate faculty development programmes.

## **CORE VALUES**

MSBTE believes in the followings:

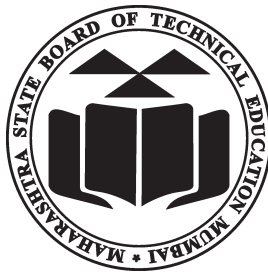
- Education industry produces live products.
- Market requirements do not wait for curriculum changes.
- Question paper is the reflector of academic standards of educational organization.
- Well designed curriculum needs effective implementation too.
- Competency based curriculum is the backbone of need based program.
- Technical skills do need support of life skills.
- Best teachers are the national assets.
- Effective teaching learning process is impossible without learning resources.

**A Laboratory Manual**  
**for**  
**Electric Circuits and**  
**Network**

**(22330)**

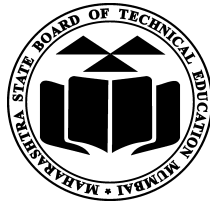
**Semester-III**

**(DE/IE/EJ/ET/EN/EX/EQ)**



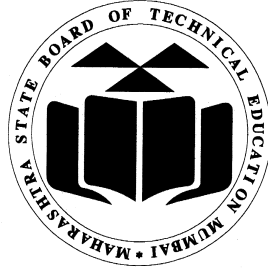
**Maharashtra State**  
**Board of Technical Education, Mumbai**

**(Autonomous) (ISO:9001:2015) (ISO/IEC 27001:2013)**



Maharashtra State Board of Technical Education,  
(Autonomous) (ISO:9001 : 2015 ) (ISO/IEC 27001 : 2013)  
4th Floor, Government Polytechnic Building, 49, Kherwadi,  
Bandra ( East ), Mumbai - 400051.

(Printed on June, 2018 )



**MAHARASHTRA STATE  
BOARD OF TECHNICAL EDUCATION**

**Certificate**

This is to certify that Mr. / Ms. ....  
Roll No. ...., of Third Semester of Diploma in  
..... of Institute,  
.....  
(Code: .....) has completed the term work satisfactorily in course  
**Electric Circuits and Networks (22330)** for the academic year 20..... to  
20..... as prescribed in the curriculum.

Place: .....

Enrollment No:.....

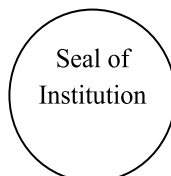
Date: .....

Exam. Seat No: .....

**Subject Teacher**

**Head of the Department**

**Principal**





## Preface

The primary focus of any engineering laboratory/ field work in the technical education system is to develop the much needed industry relevant competencies and skills. With this in view, MSBTE embarked on this innovative 'I' Scheme curricula for engineering diploma programmes with outcome-based education as the focus and accordingly, relatively large amount of time is allotted for the practical work. This displays the great importance of laboratory work making each teacher; instructor and student to realize that every minute of the laboratory time need to be effectively utilized to develop these outcomes, rather than doing other mundane activities. Therefore, for the successful implementation of this outcome-based curriculum, every practical has been designed to serve as a '*vehicle*' to develop this industry identified competency in every student. The practical skills are difficult to develop through 'chalk and duster' activity in the classroom situation. Accordingly, the 'I' scheme laboratory manual development team designed the practicals to *focus* on the *outcomes*, rather than the traditional age old practice of conducting practicals to 'verify the theory' (which may become a byproduct along the way).

This laboratory manual is designed to help all stakeholders, especially the students, teachers and instructors to develop in the student the pre-determined outcomes. It is expected from each student that at least a day in advance, they have to thoroughly read through the concerned practical procedure that they will do the next day and understand the minimum theoretical background associated with the practical. Every practical in this manual begins by identifying the competency, industry relevant skills, course outcomes and practical outcomes which serve as a key focal point for doing the practical. The students will then become aware about the skills they will achieve through procedure shown there and necessary precautions to be taken, which will help them to apply in solving real-world problems in their professional life.

This manual also provides guidelines to teachers and instructors to effectively facilitate student-centered lab activities through each practical exercise by arranging and managing necessary resources in order that the students follow the procedures and precautions systematically ensuring the achievement of outcomes in the students.

In industry, to build and test electronic/electrical circuits in different situations knowledge of electric circuits and networks is very important. This course is intended to develop the skills to diagnose and rectify the electric network and circuit related problems in the industry. The concept and principles of circuit analysis lays the foundation to understand courses of higher level.

Although best possible care has been taken to check for errors (if any) in this laboratory manual, perfection may elude us as this is the first edition of this manual. Any errors and suggestions for improvement are solicited and highly welcome

**Programme Outcomes (POs) to be achieved through Practical of this Course:**

- PO1. **Basic knowledge:** Apply knowledge of basic mathematics, sciences and basic engineering to solve the broad-based Electronics and Telecommunication engineering problems.
- PO2. **Discipline knowledge:** Apply Electronics and Telecommunication engineering knowledge to solve broad-based Electronics and Telecommunications engineering related problems.
- PO3. **Experiments and practice:** Experiments and practice: Plan to perform experiments and practices to use the results to solve broad-based Electronics and Telecommunication engineering problems.
- PO4. **Engineering tools:** Apply relevant Electronics and Telecommunications technologies and tools with an understanding of the limitations
- PO5. **The engineer and society:** Assess societal, health, safety, legal and cultural issues and the consequent responsibilities relevant to practice in field of Electronics and Telecommunication engineering.
- PO6. **Environment and sustainability:** Apply Electronics and Telecommunication engineering solutions also for sustainable development practices in societal and environmental contexts.
- PO7. **Ethics:** Apply ethical principles for commitment to professional ethics, responsibilities and norms of the practice also in the field of Electronics and Telecommunication engineering.
- PO8. **Individual and team work:** Function effectively as a leader and team member in diverse/multidisciplinary teams.
- PO9. **Communication:** Communicate effectively in oral and written form.
- PO10. **Life-long learning:** Engage in independent and life-long learning activities in the context of technological changes also in the Electronics and Telecommunication engineering and allied industry.

**Program Specific Outcomes (PSO):-**

- PSO1. Electronics and Telecommunication Systems:** Maintain various types of Electronics and Telecommunication systems.
- PSO2. EDA Tools Usage:** Use EDA tools to develop simple Electronics and Telecommunication engineering related circuits.



### **List of Industry Relevant Skills**

The following industry relevant skills of the competency '**Diagnose the electrical and electronic circuit problems.**' are expected to be developed in students by undertaking the practicals of this laboratory manual.

1. Identify the electronic/electrical circuits .
2. Test electric/electronic networks
3. Select the proper process to analyse electric/electronic circuits as per requirement.
4. Apply the appropriate law/theorem.
5. Calculate various parameter values for different networks.
6. Finding equivalent component values.
7. Compare the observed output with the expected output.
8. Find faults and trouble shoot the given circuit

### Practical- Course Outcome matrix

| <b>Course Outcomes (COs)</b>  |   |              |              |              |              |              |              |
|---|---|--------------|--------------|--------------|--------------|--------------|--------------|
| a. Check the working of single phase a. c. circuits.<br>b. Check the resonance condition of electric/electronic circuits.<br>c. Check the functionality using the principles of circuit analysis.<br>d. Use network theorems to determine the various parameters in circuits.<br>e. Use two port networks to determine the circuit parameters |   |              |              |              |              |              |              |
| <b>S. No.</b>   | <b>Practical Outcome</b>  | <b>CO a.</b> | <b>CO b.</b> | <b>CO c.</b> | <b>CO d.</b> | <b>CO e.</b> | <b>CO f.</b> |
| 1.  | Determine active, reactive and apparent power consumed in given R-L series circuit and draw phase diagram.  | √            | -            | -            | -            | -            | -            |
| 2.  | Determine active, reactive and apparent power consumed in given R-C series circuit and draw phase diagram.  | √            | -            | -            | -            | -            | -            |
| 3.  | Determine active, reactive and apparent power consumed in given R-L-C series circuit and draw phase diagram.  | √            | -            | -            | -            | -            | -            |
| 4.  | (i) Measure currents in R-C parallel A. C. circuit.<br>(ii) Determine p.f., active, reactive and apparent power in R-C a.c parallel circuit   | √            | -            | -            | -            | -            | -            |
| 5.  | (i) Measure currents in each branch of given R-L-C parallel a. c. circuit.<br>(ii) Determine p.f., active, reactive and apparent power for given R-L-C Parallel circuit with series connection of resistor and inductor in parallel with capacitor. | √            | -            | -            | -            | -            | -            |
| 6.  | Determine initial and final voltage across the capacitor at $t=0^-$ and $t=0^+$ .   | √            | -            | -            | -            | -            | -            |
| 7.  | Determine initial and final current through the inductive coil at $t=0^-$ and $t=0^+$ .   | √            | -            | -            | -            | -            | -            |
| 8.  | Create resonance in given R-L-C circuit by varying L and C or by using variable frequency supply.   | -            | √            | -            | -            | -            | -            |
| 9.  | Determine current through the given branch of a electric network by applying mesh analysis.   | -            | -            | √            | -            | -            | -            |
| 10.   | Determine voltage at the particular node and current through any given branch of the network by applying nodal analysis.  | -            | -            | √            | -            | -            | -            |

|     |  |   |   |   |   |   |   |
|-----|--|---|---|---|---|---|---|
| 11. | Determine current through the given branch and voltage across the given element of circuit by applying superposition theorem | - | - | - | √ | - | - |
| 12. | Determine equivalent circuit parameter in a given circuit by applying Thevenin's and Norton's theorem                        | - | - | - | √ | - | - |
| 13. | Determine load resistance for maximum power transfer for a given circuit by applying maximum power transfer theorem.         | - | - | - | √ | - | - |
| 14. | Test the response of the given circuit by applying reciprocity theorem.  | - | - | - | √ | - | - |
| 15. | Determine open circuit (Z) parameters for the given network.   | - | - | - |   | √ | - |
| 16. | Determine short circuit (Y) parameters for the given network.  | - | - | - | - | √ | - |
| 17. | Determine transmission (ABCD) parameters for the given network.  | - | - | - | - | √ | - |

### **Guidelines to Teachers**

1. Teacher should provide the guideline with demonstration of practical to the students with all features.
2. Teacher shall explain prior concepts to the students before starting of each practical
3. Involve students in performance of each practical.
4. Teacher should ensure that the respective skills and competencies are developed in the students after the completion of the practical exercise.
5. Teachers should give opportunity to students for hands on experience after the demonstration.
6. Teacher is expected to share the skills and competencies to be developed in the students.
7. Teacher may provide additional knowledge and skills to the students even though not covered in the manual but are expected the students by the industry.
8. Give practical assignment and assess the performance of students based on task assigned to check whether it is as per the instructions.
9. If practical is in two parts -Part I and Part II it should be conducted in two turns.
10. Teacher is expected to refer complete curriculum document and follow guidelines for implementation
11. Assess the skill achievement of the students and COs of each unit.
12. At the beginning Teacher should make the students acquainted with any of the simulation software environment as few experiments are based on simulation.
13. Teacher is expected to refer complete curriculum document and follow guidelines for implementation before start of curriculum

### **Instructions for Students**

1. Listen carefully the lecture given by teacher about course, curriculum, learning structure, skills to be developed.
2. Before performing the practical student shall read lab manual of related practical to be conducted.
3. For incidental writing on the day of each practical session every student should maintain a ***dated log book*** for the whole semester, apart from this laboratory manual which s/he has to ***submit for assessment to the teacher.***
4. Organize the work in the group and make record of all observations.
5. Students shall develop maintenance skill as expected by industries.
6. Student shall attempt to develop related hand-on skills and gain confidence.
7. Student shall develop the habits of evolving more ideas, innovations, skills etc. those included in scope of manual
8. Student shall refer technical magazines, IS codes and data books.
9. Student should develop habit to submit the practical on date and time.
10. Student should well prepare while submitting write-up of exercise.

**Content Page**  
**List of Practicals and Progressive Assessment Sheet**

| S. No | Practical Outcome   | Page No. | Date of performance | Date of submission | Assessment marks(25) | Dated sign. of teacher | Remarks (if any) |
|-------|---|----------|---------------------|--------------------|----------------------|------------------------|------------------|
| 1.    | Determine active, reactive and apparent power consumed in given R-L series circuit and draw phase diagram   | 1        |                     |                    |                      |                        |                  |
| 2.    | Determine active, reactive and apparent power consumed in given R-C series circuit and draw phase diagram.  | 9        |                     |                    |                      |                        |                  |
| 3.    | Determine active, reactive and apparent power consumed in given R-L-C series circuit and draw phase diagram.  | 18       |                     |                    |                      |                        |                  |
| 4.    | (i)Measure currents in R-C parallel A. C. circuit.<br>(ii)Determine P.F., active, reactive and apparent power in R-C A,C. parallel circuit  | 27       |                     |                    |                      |                        |                  |
| 5.    | (i)Measure currents in each branch of given R-L-C parallel a. c. circuit.<br>(ii)Determine P.F., active, reactive and apparent power for given R-L-C Parallel circuit with series connection of resistor and inductor in parallel with capacitor. | 35       |                     |                    |                      |                        |                  |
| 6.    | Determine initial and final voltage across the capacitor at $t=0^-$ and $t=0^+$ .   | 41       |                     |                    |                      |                        |                  |
| 7.    | Determine initial and final current through the inductive coil at $t=0^-$ and $t=0^+$ .   | 47       |                     |                    |                      |                        |                  |
| 8.    | Create resonance in given R-L-C circuit by varying L and C or by using variable frequency supply.   | 52       |                     |                    |                      |                        |                  |
| 9.    | Determine current through the given branch of a electric network by applying mesh analysis  | 58       |                     |                    |                      |                        |                  |
| 10.   | Determine voltage at the particular node and current through any given branch of the network by applying nodal analysis.  | 63       |                     |                    |                      |                        |                  |
| 11.   | Determine current through the given branch and voltage across the given element of circuit by applying superposition theorem  | 69       |                     |                    |                      |                        |                  |
| 12.   | Determine equivalent circuit parameter in a given circuit by applying Thevenin's and Norton's theorem   | 74       |                     |                    |                      |                        |                  |

| S. No        | Practical Outcome   | Page No. | Date of performance | Date of submission | Assessment marks(25) | Dated sign. of teacher | Remarks (if any) |
|--------------|---|----------|---------------------|--------------------|----------------------|------------------------|------------------|
| 13.          | Determine load resistance for maximum power transfer for a given circuit by applying maximum power transfer theorem | 81       |                     |                    |                      |                        |                  |
| 14.          | Test the response of the given circuit by applying reciprocity theorem  | 87       |                     |                    |                      |                        |                  |
| 15.          | Determine open circuit (Z) parameters for the given network.  | 93       |                     |                    |                      |                        |                  |
| 16.          | Determine short circuit (Y) parameters for the given network.   | 99       |                     |                    |                      |                        |                  |
| 17.          | Determine transmission (ABCD) parameters for the given network.   | 106      |                     |                    |                      |                        |                  |
| <b>Total</b> |   |          |                     |                    |                      |                        |                  |

- To be transferred to Proforma of CIAAN-2017.

## Practical No. 01:- R-L series circuit

### I **Practical Significance:**

In industries various types of electrical loads are used such as motors, lighting devices, heating devices etc. One who is using these devices must know the different types of powers i.e. Active Power, Reactive Power and Apparent Power drawn by these devices. By performing this practical student will be able to measure and interpret the active power, reactive power and apparent power consumed by the R-L series circuit.

### II **Relevant Program Outcomes (POs)**

1. **Basic knowledge:** Apply knowledge of basic mathematics, sciences and basic engineering to solve the broad-based Industrial Electronics related problems.
2. **Discipline knowledge:** Apply knowledge of basic mathematics, sciences and basic engineering to solve the broad-based Digital Electronics/Industrial Electronics/ Electronics & Telecommunication related problems.
3. **Experiments and practice:** Plan to perform experiments and practices to use the results to solve broad-based Digital Electronics/Industrial Electronics/Electronics & Telecommunication problems.
4. **Engineering tools:** Apply relevant Digital Electronics/Industrial Electronics/Electronics & Telecommunication technologies and tools with an understanding of the limitations.
5. **Communication:** Communicate effectively in oral and written form.

### III **Competency and Practical Skills:**

The aim of this course is to help the student to attain the following industry identified competency through various teaching learning experiences:

#### **Diagnose the electrical and electronic circuit problems.**

This practical is expected to develop the following skills in students.

1. Identify Electrical and Electronic components.
2. Connect components and instruments in the circuits as per the requirement.
3. Use Electrical equipment.
4. Use electrical measuring instruments.

### IV **Relevant Course Outcomes:**

Check the working of single phase A.C. circuits.

### V **Practical Outcome:**

Determine active, reactive and apparent power consumed in given R-L series circuit and draw phase diagram.

### VI **Relevant Affective domain related Outcome(s):**

- a. Practice good housekeeping
- b. Maintain tools and equipment
- c. Observe step by step sequence of operations.

**VII Minimum Theoretical Background:**

If  $V$ (r.m.s.) is the applied voltage across the series combination of R-L and

$I$ (r.m.s.) is the current flowing through the circuit, then

Voltage appearing across R =  $V_R = IR$  .....in phase with current.

Voltage appearing across L =  $V_L = IX_L$  .....leading  $90^\circ$  with current.

$$\vec{V} = \vec{V}_R + \vec{V}_L$$

If, the applied voltage is  $v = V_m \sin \omega t$ ,

then, the equation of current will be  $I = I_m \sin (\omega t - \phi )$ .

i.e. current lags behind voltage. The angle of lag (i.e.  $\phi$ ) is greater than  $0^\circ$  but less than  $90^\circ$ . It is determined by the ratio of inductive reactance to resistance in the circuit.

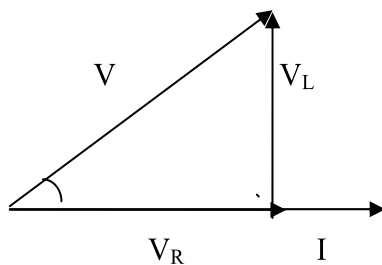
$$\tan \phi = ( X_L / R ).$$

Active Power (True Power)=  $VI \cos \phi$ . This power is measured in watts.

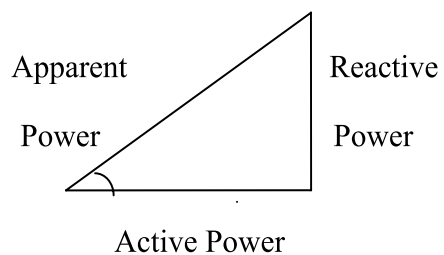
Reactive Power=  $VI \sin \phi$ . This power is measured in VAR.

Apparent Power=  $VI$ . This power is measured in VA.

**Phasor diagram:**



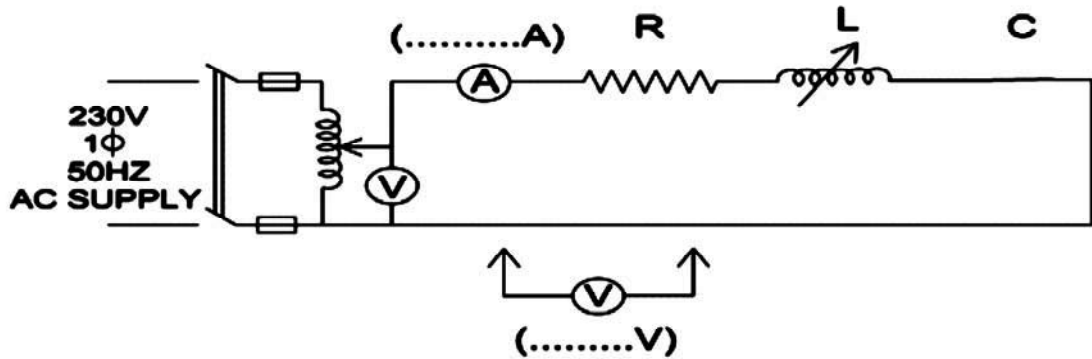
**Figure 1.1:** Phase diagram for R-L series circuit



**Figure 1.2:** Power triangle



**VIII Practical Circuit Diagram:**  
**a) Sample**



(Note: voltmeter must be connected across each component)

Figure 1.3:

**b) Actual Circuit / Experimental set up used in laboratory:**

**IX Resources required:**

| Sr. No. | Instrument /Components | Specification      | Quantity | Remarks |
|---------|------------------------|--------------------|----------|---------|
| 1.      | Autotransformer        | Single phase, 1kVA | 01       |         |
| 2.      | A.C. Voltmeter         | 0-600V MI type     | 02       |         |
| 3.      | A.C. Ammeter           | 0-5Amp MI type     | 01       |         |
| 4.      | Rheostat               | 100 Ω, 5A          | 01       |         |
| 5.      | Choke coil             | 100mH              | 01       |         |

**X Precautions:**

1. Initially set the autotransformer to zero position.
2. Apply voltage as per rating of the resistor and inductor series combination.

**XI Procedure:**

1. Select equipments, instruments and components as per the resources required table.
2. Connect the circuit as shown in figure 1.3.
3. Switch on the supply.
4. Vary the voltage by using autotransformer in steps of (say) 100V, 150V, 200V to get three readings.
5. Record the values of V, I,  $V_R$  and  $V_L$  in table no. 1.
6. Reduce the voltage to zero and switch off the supply.
7. Calculate the values of circuit components i.e. resistance 'R', inductive reactance ' $X_L$ ' (Neglect resistance of inductor), inductance 'L'.
8. Calculate impedance 'Z' and phase angle ' $\phi$ '.
9. Now calculate active, reactive and apparent power.

**XII Resources used (with major specifications):**

| S. No. | Instrument /Components | Specification | Quantity |
|--------|------------------------|---------------|----------|
| 1.     |                        |               |          |
| 2.     |                        |               |          |
| 3.     |                        |               |          |
| 4.     |                        |               |          |
| 5.     |                        |               |          |

**XIII Actual procedure followed**

.....

.....

.....

.....

.....

.....

.....

.....

**XIV Precautions followed**

.....

.....

.....

.....

.....

**XV Observations and Calculations****Table 1.1: Measurement of V and I and calculation of power**

| Sr. No | Measured   |       |                    |                    | Calculated |       |                    |        |   |                  |                      |                     |
|--------|------------|-------|--------------------|--------------------|------------|-------|--------------------|--------|---|------------------|----------------------|---------------------|
|        | V (V)      | I (A) | V <sub>R</sub> (V) | V <sub>L</sub> (V) | Z (Ω)      | R (Ω) | X <sub>L</sub> (Ω) | L (mH) | φ | Active Power (W) | Reactive Power (VAr) | Apparent Power (VA) |
| 1      |            |       |                    |                    |            |       |                    |        |   |                  |                      |                     |
| 2      |            |       |                    |                    |            |       |                    |        |   |                  |                      |                     |
| 3      |            |       |                    |                    |            |       |                    |        |   |                  |                      |                     |
|        | Mean value |       |                    |                    |            |       |                    |        |   |                  |                      |                     |

**Calculations:**

Calculate-

1.  $Z = (V / I) \Omega$  Also verify  $Z = \sqrt{R^2 + X_L^2} \Omega$
2.  $R = (V_R / I) \Omega$
3.  $X_L = (V_L / I) \Omega$
4.  $L = (X_L / 2\pi f) \text{ H}$
5.  $\cos\phi = (R / Z)$
6. Active Power =  $(VI\cos\phi) \text{ W}$
7. Reactive Power =  $(VI\sin\phi) \text{ VAr}$
8. Apparent Power =  $(VI) \text{ VA}$

**Phasor diagrams:****For reading no.1****For reading no.2****For reading no.3**

**XVI Results**

1. Active Power= .....
2. Reactive Power= .....
3. Apparent Power= .....

**XVII Interpretation of results**

.....  
.....  
.....

**XVIII Conclusions and Recommendation**

.....  
.....  
.....

**XIX Practical related Questions**

1. Write the specifications of autotransformer used in the experiment from the name plate.
2. What will be the effect on the values of resistance and inductance if we apply the voltage in steps of 10V?
3. How the selection of proper value of resistance is made for this experiment?
4. Suggest the method to change the p.f. of the circuit.
5. ....

**[Space for Answers]**

.....  
.....  
.....  
.....  
.....  
.....  
.....  
.....  
.....  
.....  
.....  
.....  
.....  
.....  
.....  
.....  
.....  
.....  
.....  
.....  
.....  
.....

**XX References / Suggestions for further Reading-**

SudhakarA.,PalliShyammohan-Circuit and network - Tata McGraw Hill, New Delhi, 2006

ISBN :978-0-07-340458-5 Learning websites-

- a. www.cesim.com/simulations
- b. www.youtube.com /electric circuits
- c. www.dreamtechpress.com /ebooks
- d. www.nptelvideos.in/electrical engineering/ circuit theory
- e. www.learnerstv.com/free-engineering

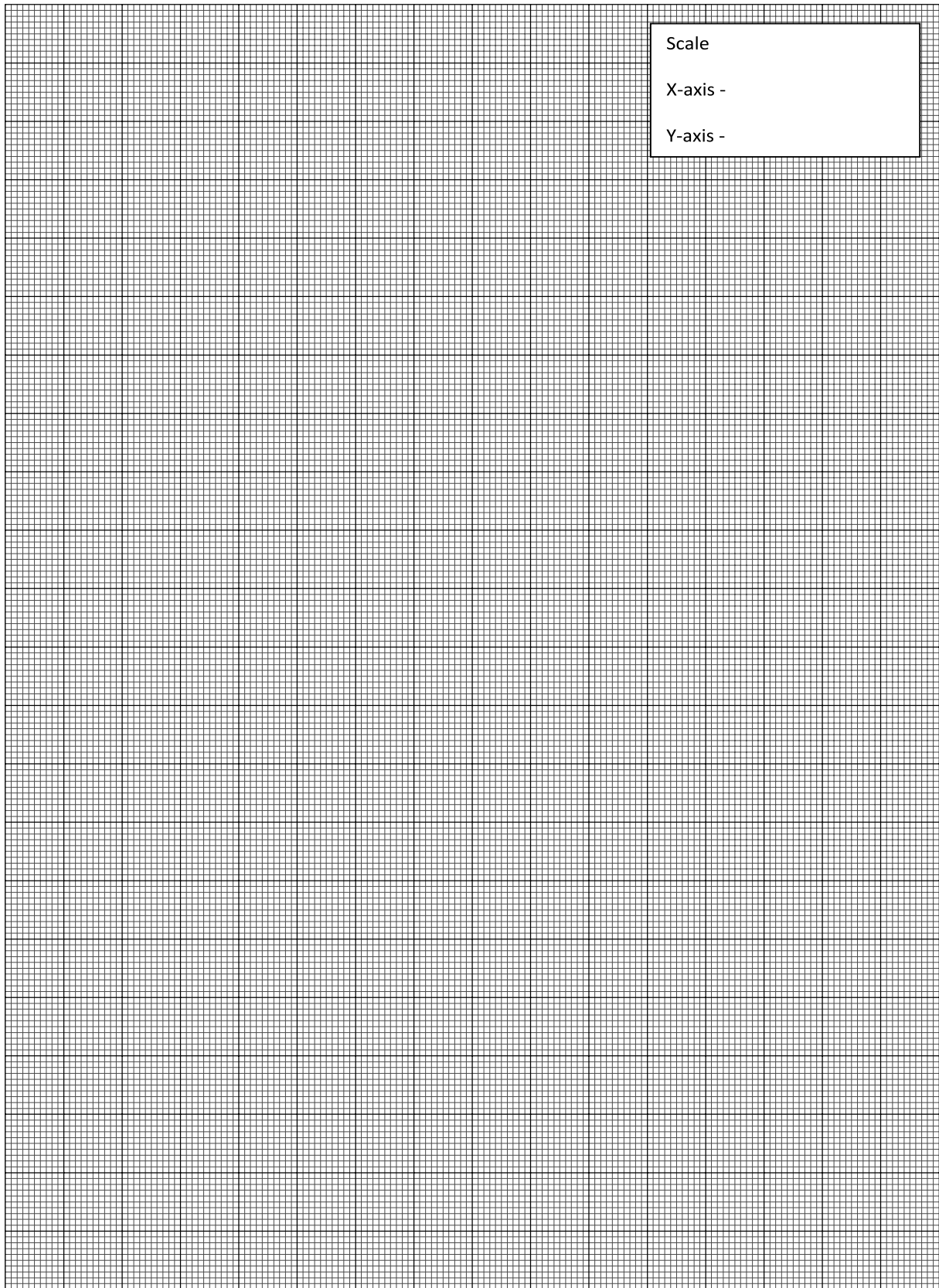
**XXI Assessment Scheme:-**

| Performance indicators            |   | Weightage    |
|-----------------------------------|---|--------------|
| <b>Process related (10 Marks)</b> |   | <b>40%</b>   |
| 1                                 | Selection of equipment, components, instruments | 10%          |
| 2                                 | Proper connection of circuit                    | 10%          |
| 3                                 | Neatness in the arrangement of circuit          | 10%          |
| 4                                 | Procedural steps followed                       | 10%          |
| <b>Product related (15 Marks)</b> |   | <b>60%</b>   |
| 5                                 | Accuracy in calculations                        | 20%          |
| 6                                 | Representation of phase diagram                 | 20%          |
| 7                                 | Interpretation of results                       | 10%          |
| 8                                 | Conclusion                                      | 05%          |
| 9                                 | Submitting the journal in time                  | 05%          |
| <b>Total (25 Marks)</b>           |   | <b>100 %</b> |

***Names of Student Team Members***

1. ....
2. ....
3. ....
4. ....

| Marks Obtained      |                     |            | Dated signature of Teacher |
|---------------------|---------------------|------------|----------------------------|
| Process Related(15) | Product Related(10) | Total (25) |                            |
|                     |                     |            |                            |



## **Practical No.02: R-C Series circuit**

### **I Practical Significance:**

Most of the load present on the power supply system is of resistive and inductive in nature. Transmission lines also have some resistance and inductance. Due to this, power factor of that particular system, consisting of inductive load becomes lagging and consumption of electrical power increases. Capacitive loads are having leading power factor, which compensate for lagging power drawn by the inductive load. Hence it is necessary to understand the Active Power, Reactive Power and Apparent Power consumed by resistive and capacitive load. By performing this practical you will be able to measure and interpret the active power, reactive power and apparent power consumed by the R-C series circuit.

### **II Relevant Program Outcomes (POs) :**

1. **Basic knowledge:** Apply knowledge of basic mathematics, sciences and basic engineering to solve the broad-based Industrial Electronics related problems.
2. **Discipline knowledge:** Apply knowledge of basic mathematics, sciences and basic engineering to solve the broad-based Digital Electronics/Industrial Electronics/ Electronics & Telecommunication related problems.
3. **Experiments and practice:** Plan to perform experiments and practices to use the results to solve broad-based Digital Electronics/Industrial Electronics/Electronics & Telecommunication problems.
4. **Engineering tools:** Apply relevant Digital Electronics/Industrial Electronics/Electronics & Telecommunication technologies and tools with an understanding of the limitations.

### **III Competency and Practical Skills:**

The aim of this course is to help the student to attain the following industry identified competency through various teaching learning experiences:

**Diagnose the electrical and electronic circuit problems.**

This practical is expected to develop the following skills in students.

1. Identify Electrical & Electronic components.
2. Use Electrical equipment.
3. Use electrical measuring instruments.

### **IV Relevant Course Outcomes**

Check the working of single phase A.C. circuits.

### **V Practical Outcome:**

Determine active, reactive and apparent power consumed in given R-C series circuit and draw phase diagram.

**VI Relevant affective domain related Outcome(s)**

- a. Practice good housekeeping.
- b. Demonstrate working as a leader / a team member.
- c. Maintain tools and equipment.
- d. Observe step by step sequence of operations.

**VII Minimum Theoretical Background**

If  $V(\text{r.m.s.})$  is the applied voltage across the series combination of R-C and  $I(\text{r.m.s.})$  is the current flowing through the circuit, then

Voltage appearing across R =  $V_R = IR$  .....in phase with current.

Voltage appearing across C =  $V_C = IX_C$  .....lagging  $90^\circ$  with current

$$V = V_R + V_C$$

If, the applied voltage is  $v = V_m \sin \omega t$ ,

then, the equation of current will be  $I = I_m \sin (\omega t + \phi)$ .

i.e. in series R-C circuit current leads the applied voltage by  $\phi$ .

The angle of lead (i.e.  $\phi$ ) is determined by the ratio of capacitive reactance to resistance the circuit.

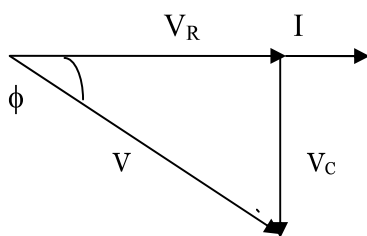
$\tan \phi = (-X_C/R)$ , The negative phase angle implies that voltage lags behind the current.

Active Power (True Power) =  $VI \cos \phi$ . This power is measured in watts.

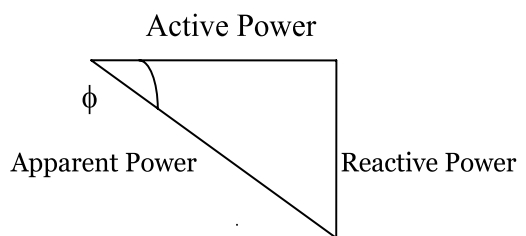
Reactive Power =  $VI \sin \phi$ . This power is measured in VAR.

Apparent Power =  $VI$ . This power is measured in VA.

**Phasor Diagram:**



**Figure 2.1:** Phasor diagram for R-C series circuit

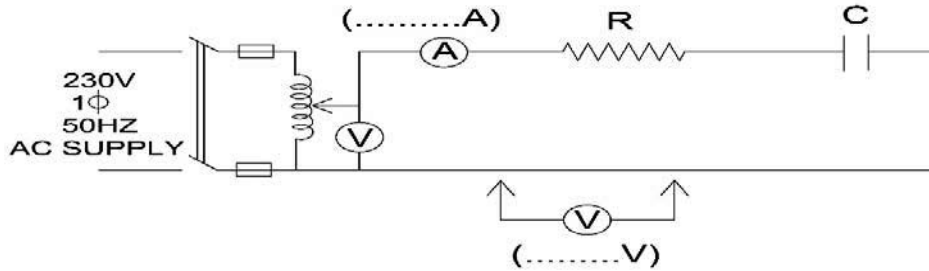


**Figure 2.2:** Power triangle



### VIII Practical Circuit Diagram

a) **Sample**



(Note voltmeter must be connected across each components)

**Figure 2.3:**

b) **Actual Circuit / Experimental set up used in laboratory:**

### IX Resources required

Following Table Format Should be Single Line:

| Sr. No. | Instrument /Components | Specification                      | Quantity | Remarks |
|---------|------------------------|------------------------------------|----------|---------|
| 1.      | Autotransformer        | Single phase, 1kVA                 | 01       |         |
| 2.      | A.C. Voltmeter         | MI Type 0-600V                     | 02       |         |
| 3.      | A.C. Ammeter           | MI Type 0-5Amp                     | 01       |         |
| 4.      | Rheostat               | 200 $\Omega$ , 5A                  | 01       |         |
| 5.      | Capacitor              | 1.0 $\mu$ F / 400V or higher value | 01       |         |

### X Precautions

1. Discharge the capacitor before and after use.
2. Initially set the autotransformer to zero position.
3. Apply voltage as per rating of the resistor and capacitor series combination.

**XI Procedure**

1. Select equipment, instruments and components as per the resources required table.
2. Connect the circuit as shown in figure2.3.
3. Switch on the supply.
4. Vary the voltage by using autotransformer in steps of (say) 100V, 150V, 200V to get three readings.
5. Record the values of V, I,  $V_R$  and  $V_C$  in table no. 1.
6. Reduce the voltage to zero and switch off the supply.
7. Calculate the values of circuit components i.e. resistance 'R', capacitive reactance ' $X_C$ ' (Neglect resistance of capacitor), capacitance 'C'.
8. Calculate impedance 'Z' and phase angle ' $\phi$ '.
9. Now calculate active, reactive and apparent power.

**XII Resources used (with major specifications):**

| S. No. | Instrument /Components | Specification | Quantity |
|--------|------------------------|---------------|----------|
| 1.     |                        |               |          |
| 2.     |                        |               |          |
| 3.     |                        |               |          |
| 4.     |                        |               |          |
| 5.     |                        |               |          |

**XIII Actual procedure followed**

.....

.....

.....

.....

.....

.....

.....

.....

.....

**XIV Precautions followed**

.....

.....

.....

.....

.....

.....

.....

**XV Observations and Calculations****Table 2.1: Measurement of V and I and calculation of power**

| Sr. No | Measured   |       |                    |                    | Calculated |       |                    |        |   |                  |                      |                     |
|--------|------------|-------|--------------------|--------------------|------------|-------|--------------------|--------|---|------------------|----------------------|---------------------|
|        | V (V)      | I (A) | V <sub>R</sub> (V) | V <sub>C</sub> (V) | Z (Ω)      | R (Ω) | X <sub>C</sub> (Ω) | C (μF) | φ | Active Power (W) | Reactive Power (VAr) | Apparent Power (VA) |
| 1      |            |       |                    |                    |            |       |                    |        |   |                  |                      |                     |
| 2      |            |       |                    |                    |            |       |                    |        |   |                  |                      |                     |
| 3      |            |       |                    |                    |            |       |                    |        |   |                  |                      |                     |
|        | Mean value |       |                    |                    |            |       |                    |        |   |                  |                      |                     |

**Calculations:**

Calculate-

1.  $Z = (V / I) \Omega$  Also verify  $Z = \sqrt{R^2 + X_C^2} \Omega$
2.  $X_C = (V_C / I) \Omega$
3.  $C = (1 / 2\pi f X_C) F$
4.  $\cos\phi = (R / Z)$
5. Active Power =  $(VI \cos\phi) W$
6. Reactive Power =  $(VI \sin\phi) VAr$
7. Apparent Power =  $(VI) VA$

**Phasor diagrams:****For reading no.1****For reading no.2****For reading no.3**





**XX References / Suggestions for further Reading**

SudhakarA.,PalliShyammohan - Circuit and network - Tata McGraw Hill, New Delhi, 2006 ISBN :978-0-07-340458-5

**Learning websites-**

- a. [www.cesim.com/simulations](http://www.cesim.com/simulations)
- b. [www.youtube.com /electric circuits](http://www.youtube.com/electric%20circuits)
- c. [www.dreamtechpress.com /ebooks](http://www.dreamtechpress.com/ebooks)
- d. [www.nptelvideos.in/electrical engineering/ circuit theory](http://www.nptelvideos.in/electrical%20engineering/circuit%20theory)
- e. [www.learnerstv.com/free-engineering](http://www.learnerstv.com/free-engineering)

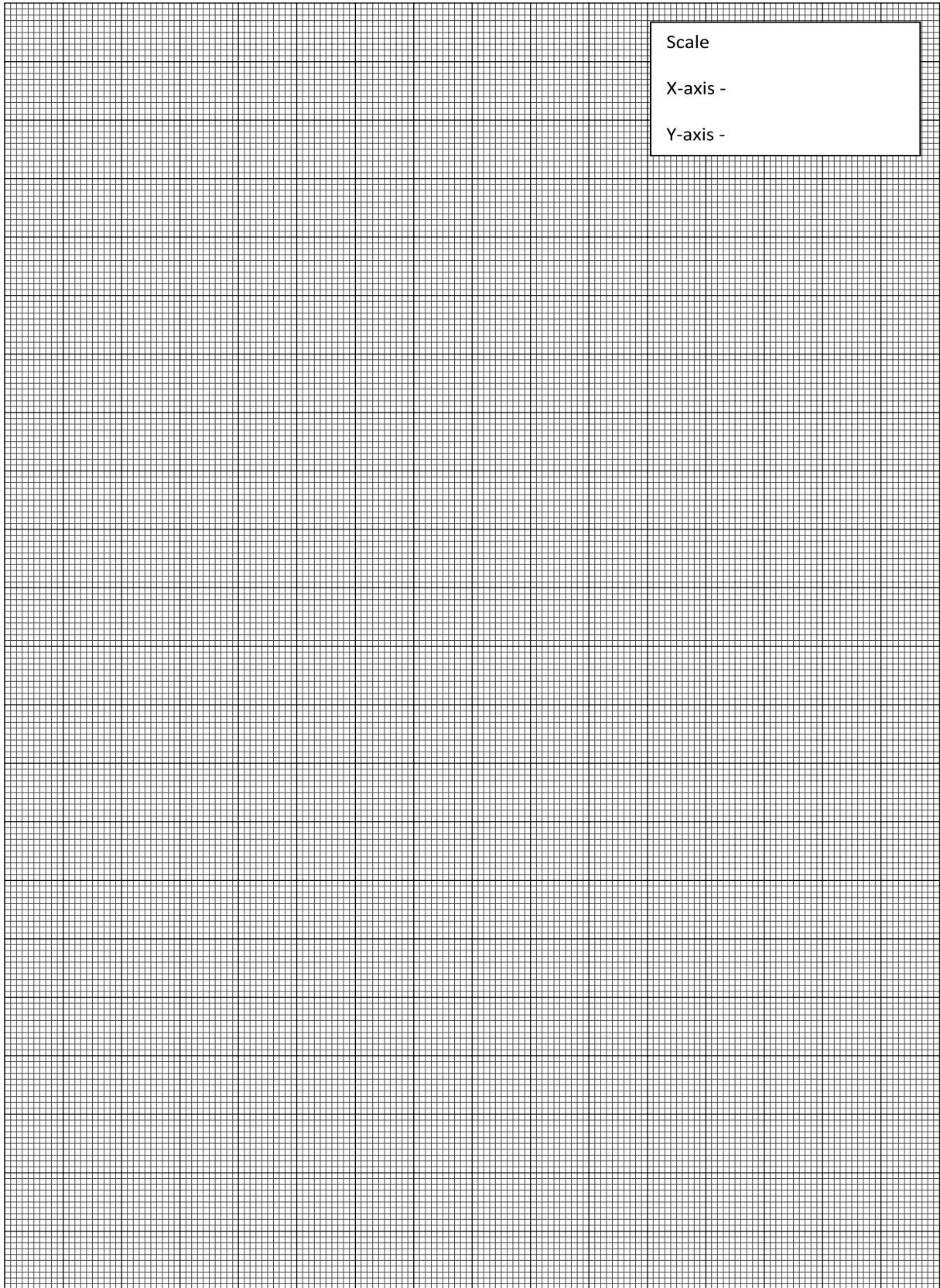
**XXI Assessment Scheme**

| Performance indicators            |   | Weightage    |
|-----------------------------------|---|--------------|
| <b>Process related (10 Marks)</b> |   | <b>40%</b>   |
| 1                                 | Selection of equipment, components, instruments | 10%          |
| 2                                 | Proper connection of circuit                    | 10%          |
| 3                                 | Neatness in the arrangement of circuit          | 10%          |
| 4                                 | Procedural steps followed                       | 10%          |
| <b>Product related (15 Marks)</b> |   | <b>60%</b>   |
| 5                                 | Accuracy in calculations                        | 20%          |
| 6                                 | Representation of phase diagram                 | 20%          |
| 7                                 | Interpretation of results                       | 10%          |
| 8                                 | Conclusion                                      | 05%          |
| 9                                 | Submitting the journal in time                  | 05%          |
| <b>Total (25 Marks)</b>           |   | <b>100 %</b> |

***Names of Student Team Members***

1. ....
2. ....
3. ....
4. ....

| Marks Obtained         |                        |               | Dated signature of<br>Teacher |
|------------------------|------------------------|---------------|-------------------------------|
| Process<br>Related(15) | Product<br>Related(10) | Total<br>(25) |                               |
|                        |                        |               |                               |



## Practical No.03: R-L-C series circuit

### I Practical Significance

Electrical load present on the power supply system is mostly resistive and inductive in nature. Due to inductive load, power factor of the system becomes low and more power is consumed from the supply system. Therefore for power factor improvement capacitors are used in the circuit. Hence understanding overall behavior of the circuit when resistive, inductive and capacitive loads are present is very important. One who is using these loads must understand different types of powers i.e. Active Power, Reactive Power and Apparent Power drawn by these loads. By performing this practical you will be able to measure and interpret the active power, reactive power and apparent power consumed by the R-L-C series circuit.

### II Relevant Program Outcomes (POs)

- **Basic knowledge:** Apply knowledge of basic mathematics, sciences and basic engineering to solve the broad-based Industrial Electronics related problems.
- **Discipline knowledge:** Apply knowledge of basic mathematics, sciences and basic engineering to solve the broad-based Digital Electronics/Industrial Electronics/Electronics & Telecommunication related problems.
- **Experiments and practice:** Plan to perform experiments and practices to use the results to solve broad-based Digital Electronics/Industrial Electronics/Electronics & Telecommunication problems.
- **Engineering tools:** Apply relevant Digital Electronics/Industrial Electronics/Electronics & Telecommunication technologies and tools with an understanding of the limitations.
- **Life-long learning:** Engage in independent and life-long learning activities in the context of technological changes also in the Industrial Electronics based industry.

### III Competency and Practical Skills

The aim of this course is to help the student to attain the following industry identified competency through various teaching learning experiences:

**Diagnose the electrical and electronic circuit problems.**

This practical is expected to develop the following skills in students.

1. Identify Electrical & Electronic components.
2. Use Electrical equipment.
3. Use electrical measuring instruments.

### IV Relevant Course Outcomes

1. Check the working of single phase A.C.circuits.
2. Check the resonance condition of electric / electronic circuits.

### V Practical Outcome

Determine active, reactive and apparent power consumed in given R-L-C series circuit and draw phase diagram.



**VI Relevant Affective domain related Outcome(s)**

- a. Follow safe practices.
- b. Practice good housekeeping
- c. Maintain tools and equipment properly.
- d. Observe step by step sequence of operations.

**VII Minimum Theoretical Background**

If  $V$ (r.m.s.) is the applied voltage across the series combination of R-L-C and  $I$ (r.m.s.) is the current flowing through the circuit, then

Voltage appearing across R =  $V_R = IR$  .....in phase with current.

Voltage appearing across L =  $V_L = IX_L$  .....leading  $90^\circ$  with current.

Voltage appearing across C =  $V_C = IX_C$  .....lagging  $90^\circ$  with current

$$\vec{V} = \vec{V}_R + \vec{V}_L + \vec{V}_C$$

The circuit can either be effectively inductive or capacitive depending upon which voltage drop  $V_L$  or  $V_C$  is predominant.

Three cases of R-L-C series circuit-

- i. When  $X_L > X_C$ , then  $V_L > V_C$ , phase angle is positive, and circuit current is lagging applied voltage by phase angle  $\phi$ .

$$\tan\phi = (X_L - X_C) / R.$$

- ii. When  $X_L < X_C$ , then  $V_L < V_C$ , phase angle is negative and circuit current is leading applied voltage by phase angle  $\phi$ .

$$\tan\phi = (X_C - X_L) / R.$$

- iii. When  $X_L = X_C$ , then  $V_L = V_C$ , phase angle is zero and circuit current is in phase with applied voltage. Power factor of the circuit is unity. This condition is known as series resonance. Current drawn by the circuit is maximum.

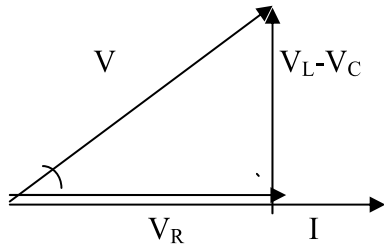
Active Power (True Power) =  $VI\cos\phi$ . This power is measured in watts

Reactive Power =  $VI\sin\phi$ . This power is measured in VAR

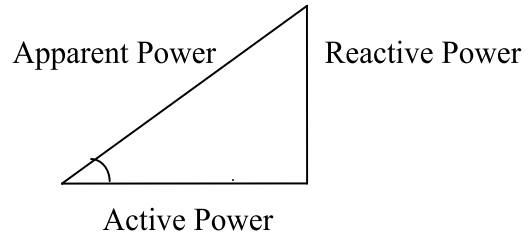
Apparent Power =  $VI$ . This power is measured in VA

**Phasor diagrams**

I)

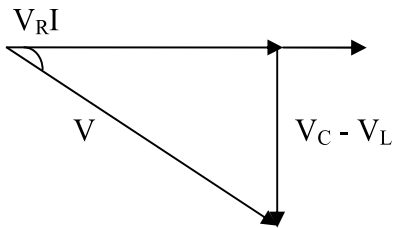


**Figure 3.1:** Phasor diagram for R-L-C series circuit  
When  $X_L > X_C$

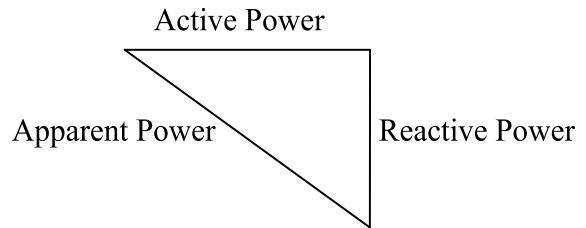


**Figure 3.2:** Power triangle  
When  $X_L > X_C$

II)

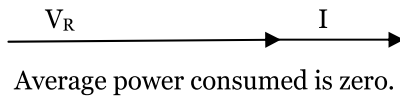


**Figure 3.3:** Phasor diagram for R-L-C series circuit  
When  $X_L < X_C$



**Figure 3.4:** Power triangle  
When  $X_L < X_C$

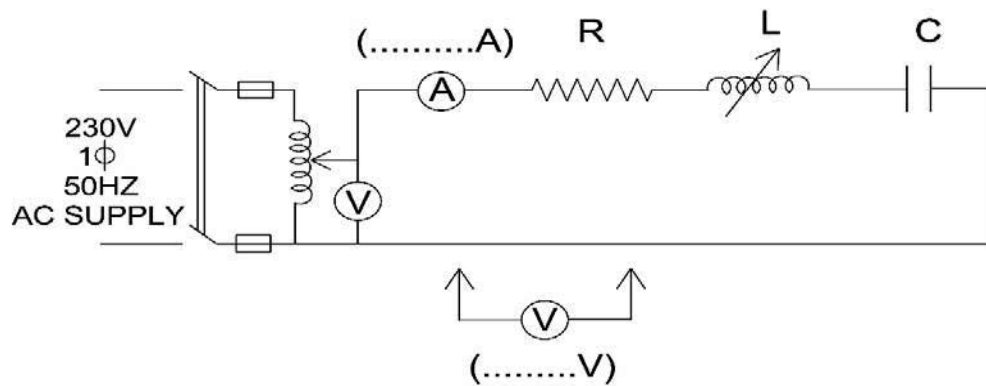
III)



**Figure 3.5:** Phasor diagram for R-L-C series circuit  
When  $X_L = X_C$

**VIII Practical Circuit Diagram**

a) Sample



(Note voltmeter must be connected across each components )

**Figure 3.6:**

**b) Actual Circuit / Experimental set up used in laboratory****IX Resources required**

Following Table Format Should be Single Line

| Sr. No | Instrument /Components | Specification                      | Quantity | Remarks |
|--------|------------------------|------------------------------------|----------|---------|
| 1.     | Autotransformer        | Single phase, 1kVA                 | 01       |         |
| 2.     | A.C. Voltmeter         | 0-600V                             | 02       |         |
| 3.     | A.C. Ammeter           | 0-5Amp                             | 01       |         |
| 4.     | Rheostat               | 100 $\Omega$ , 5A                  | 01       |         |
| 5.     | Choke coil             | 100 mH                             | 01       |         |
| 6.     | Capacitor              | 1.0 $\mu$ F / 400V or higher value | 01       |         |

**X Precautions**

1. Discharge the capacitor before and after use.
2. Initially set the autotransformer to zero position and rheostat to maximum position.

**XI Procedure:**

1. Select equipment, instruments and components as per the resources required table.
2. Connect the circuit as shown in figure 3.6.
3. Switch on the supply.
4. Vary the voltage by using autotransformer such that voltage across capacitor will not exceed its rated value.
5. Vary the inductor to get three readings such that the three conditions of R-L-C series circuit i.e.  $X_L > X_C$ ,  $X_L < X_C$  and  $X_L = X_C$  can be obtained.
6. Record the values of V, I,  $V_R$ ,  $V_L$  and  $V_C$  in table no. 1.
7. Reduce the voltage to zero and switch off the supply.
8. Calculate the values of circuit components i.e. resistance 'R', inductive reactance ' $X_L$ ' (Neglect resistance of inductor), inductance 'L', capacitive reactance ' $X_C$ ' (Neglect resistance of capacitor), capacitance C.
9. Calculate impedance 'Z' and phase angle ' $\phi$ '.
10. Now calculate active, reactive and apparent power.

**XII Resources used (with major specifications)**

| S. No. | Instrument /Components | Specification | Quantity |
|--------|------------------------|---------------|----------|
| 1.     |                        |               |          |
| 2.     |                        |               |          |
| 3.     |                        |               |          |
| 4.     |                        |               |          |
| 5.     |                        |               |          |
| 6.     |                        |               |          |

**XIII Actual procedure followed**

.....  
 .....  
 .....

**XIV Precautions followed**

.....  
 .....  
 .....

**XV Observations and Calculations**

**Table 1: Measurement of V and I and calculation of power**

| Sr. No | Measured   |       |                    |                    |                    | Calculated |       |                    |                    |        |        |   |                  |                      |                     |  |
|--------|------------|-------|--------------------|--------------------|--------------------|------------|-------|--------------------|--------------------|--------|--------|---|------------------|----------------------|---------------------|--|
|        | V (V)      | I (A) | V <sub>R</sub> (V) | V <sub>L</sub> (V) | V <sub>C</sub> (V) | Z (Ω)      | R (Ω) | X <sub>L</sub> (Ω) | X <sub>C</sub> (Ω) | L (mH) | C (μF) | φ | Active Power (W) | Reactive Power (VAr) | Apparent Power (VA) |  |
| 1      |            |       |                    |                    |                    |            |       |                    |                    |        |        |   |                  |                      |                     |  |
| 2      |            |       |                    |                    |                    |            |       |                    |                    |        |        |   |                  |                      |                     |  |
| 3      |            |       |                    |                    |                    |            |       |                    |                    |        |        |   |                  |                      |                     |  |
|        | Mean value |       |                    |                    |                    |            |       |                    |                    |        |        |   |                  |                      |                     |  |

**Calculations:**

Calculate-

- $Z = (V / I) \Omega$  Also verify  $Z = \sqrt{R^2 + (X_C^2 - X_L^2)} \Omega$
- $R = (V_R / I) \Omega$
- $X_L = (V_L / I) \Omega$
- $L = (X_L / 2\pi f) H$

- 5.  $X_C = (V_C / I) \Omega$
- 6.  $C = (1 / 2\pi f X_C) F$
- 7.  $\cos\phi = (R / Z)$
- 8. Active Power =  $(VI\cos\phi) W$
- 9. Reactive Power =  $(VI\sin\phi) VAR$
- 10. Apparent Power =  $(VI) VA$

**Phasor diagrams:**

**For reading no.1**

**For reading no.2**

**For reading no.3**

**XVI Results**

- 1. Active Power= .....
- 2. Reactive Power= .....
- 3. Apparent Power = .....

**XVII Interpretation of results**

.....  
.....  
.....

**XVIII Conclusions and Recommendation**

.....  
.....  
.....

**XIX Practical related Questions**

- 1. Write the specifications of autotransformer used in the experiment from the name plate.
- 2. How the selection of proper value of resistance is made for this experiment?
- 3. Suggest the methods to change the p.f. of the circuit.



**XX References / Suggestions for further Reading**

Sudhakar A., PalliShyammohan- Circuit and network -Tata McGraw Hill, New Delhi, 2006 ISBN :978-0-07-340458-5

Learning websites-

- www.cesim.com/simulations
- www.youtube.com /electric circuits
- www.dreamtechpress.com /ebooks
- www.nptelvideos.in/electrical engineering/ circuit theory
- www.learnerstv.com/free-engineering

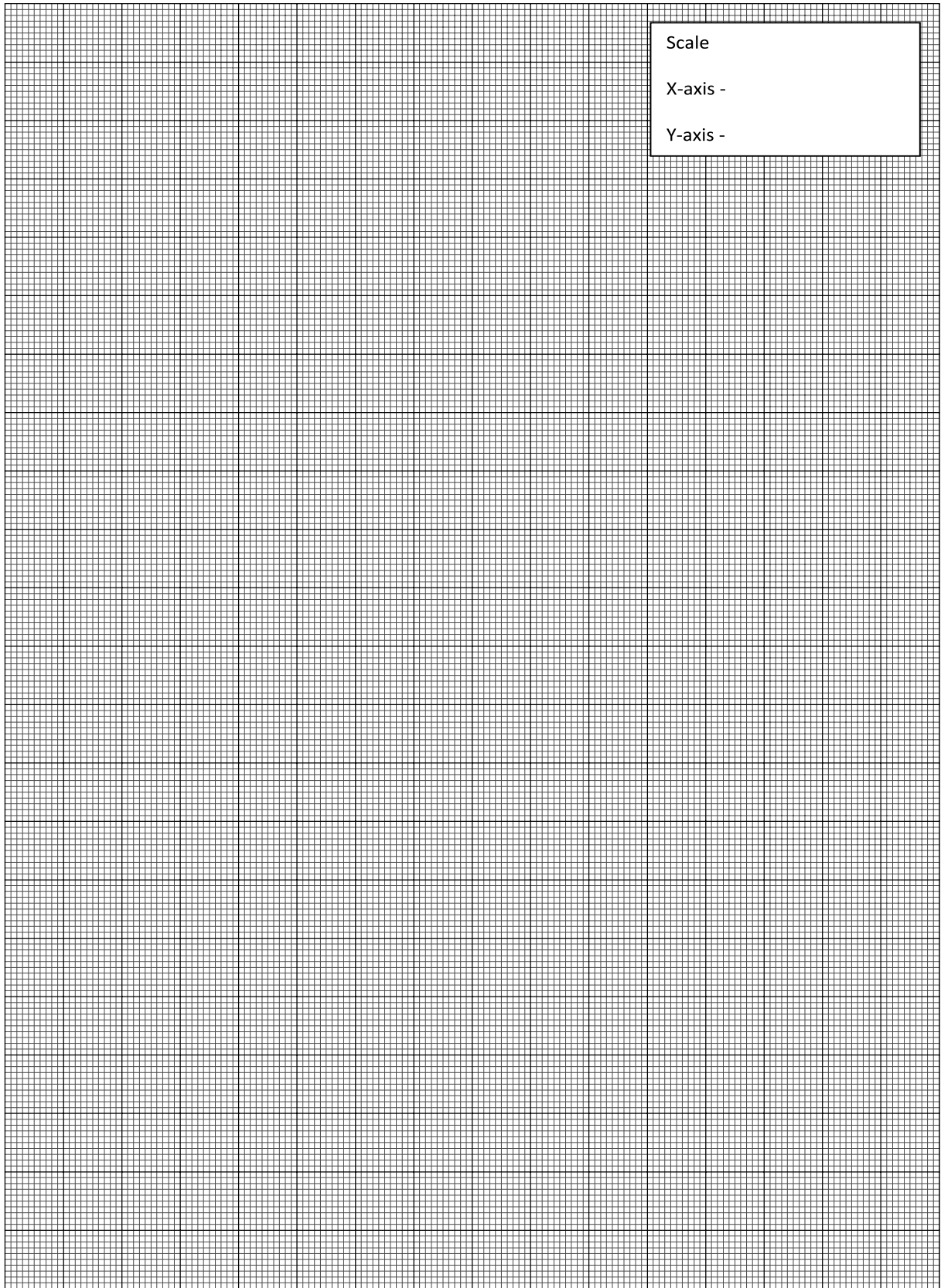
**XXI Assessment Scheme**

| <b>Performance indicators</b>     |   | <b>Weightage</b> |
|-----------------------------------|---|------------------|
| <b>Process related (10 Marks)</b> |   | <b>40%</b>       |
| 1                                 | Selection of equipment, components, instruments | 10%              |
| 2                                 | Proper connection of circuit                    | 10%              |
| 3                                 | Neatness in the arrangement of circuit          | 10%              |
| 4                                 | Procedural steps followed                       | 10%              |
| <b>Product related (15 Marks)</b> |   | <b>60%</b>       |
| 5                                 | Accuracy in calculations                        | 20%              |
| 6                                 | Representation of phase diagram                 | 20%              |
| 7                                 | Interpretation of results                       | 10%              |
| 8                                 | Conclusion                                      | 05%              |
| 9                                 | Submitting the journal in time                  | 05%              |
| <b>Total (25 Marks)</b>           |   | <b>100 %</b>     |

***Names of Student Team Members***

- .....
- .....
- .....
- .....

| <b>Marks Obtained</b>      |                            |                   | <b>Dated signature of Teacher</b> |
|----------------------------|----------------------------|-------------------|-----------------------------------|
| <b>Process Related(15)</b> | <b>Product Related(10)</b> | <b>Total (25)</b> |                                   |
|                            |                            |                   |                                   |





## Practical No. 04: R-C Parallel Circuit

### I Practical Significance:

Parallel circuits are used more frequently in electrical systems than series circuits. Most of the applications requiring different currents at the same voltage are to be connected to the same power supply by connecting them in parallel. This type of circuit is used to compensate the reactive power consumed by inductive load. By performing this practical you will be able to measure and interpret the active power, reactive power and apparent power consumed by the R-C parallel circuit.

### II Relevant Program Outcomes (POs)

1. **Basic knowledge:** Apply knowledge of basic mathematics, sciences and basic engineering to solve the broad-based Industrial Electronics related problems.
2. **Discipline knowledge:** Apply knowledge of basic mathematics, sciences and basic engineering to solve the broad-based Digital Electronics/Industrial Electronics/Electronics & Telecommunication related problems.
3. **Experiments and practice :** Plan to perform experiments and practices to use the results to solve broad-based Digital Electronics/Industrial Electronics/Electronics & Telecommunication problems.
4. **Engineering tools:** Apply relevant Digital Electronics/Industrial Electronics/Electronics & Telecommunication technologies and tools with an understanding of the limitations.
5. **Communication:** Communicate effectively in oral and written form

### III Competency and Practical Skills

The aim of this course is to help the student to attain the following industry identified competency through various teaching learning experiences:

#### **Diagnose the electrical and electronic circuit problems.**

This practical is expected to develop the following skills in students.

1. Connect components and instruments in the circuits per the requirement.
2. Use Electrical equipment.
3. Use electrical measuring instruments.

### IV Relevant Course Outcomes:

Check the working of single phase a.c .circuits.

### V Practical Outcome:

- (i) Measure currents in R-C parallel A.C. circuit.
- (ii) Determine p.f, active, reactive and apparent power in R-C parallel a.c. circuit.

**VI Relevant Affective domain related Outcome(s)**

- a. Follow safe practices.
- b. Practice good housekeeping.
- c. Maintain tools and equipment.
- d. Observe step by step sequence of operations.

**VII Minimum Theoretical Background**

If  $V(\text{r.m.s.})$  is the applied voltage across the parallel combination of R-C and  $I(\text{r.m.s.})$  is the resultant current flowing through the circuit, then

Current flowing through R =  $I_R$ .....in phase with voltage.

Current flowing through C =  $I_C$  .....leading  $90^\circ$  with voltage.  $\vec{I} = \vec{I}_R + \vec{I}_C$

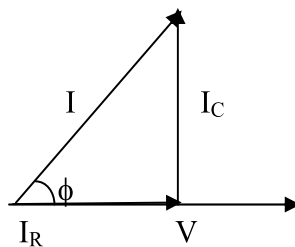
Phase angle,  $\phi = \tan^{-1} \omega CR$

Active Power (True Power)= $VI\cos\phi$ . This power is measured in watts.

Reactive Power= $VI\sin\phi$ . This power is measured in VAR.

Apparent Power= $VI$ . This power is measured in VA.

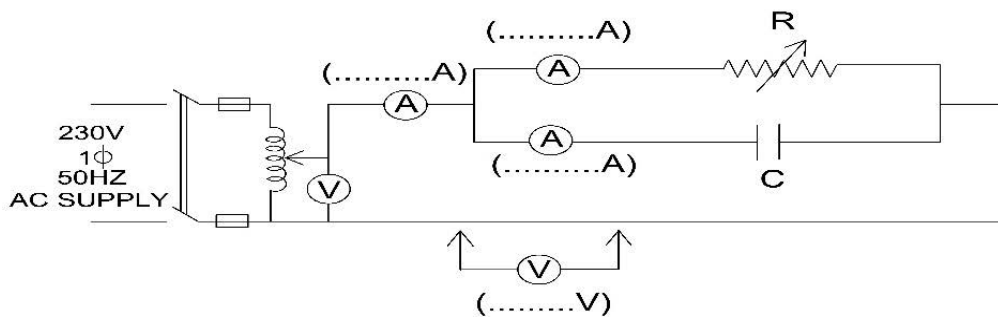
**Phasor diagram:**



**Figure: 4.1**

**VIII Practical Circuit Diagram**

**a) Sample**



(Note voltmeter must be connected across each components )

**Figure 4.2**

**b) Actual Circuit / Experimental set up used in laboratory:****IX Resources required:**

Following Table Format Should be Single Line:

| Sr. No. | Instrument /Components | Specification      | Quantity | Remarks |
|---------|------------------------|--------------------|----------|---------|
| 1.      | Autotransformer        | Single phase, 1kVA | 01       |         |
| 2.      | A.C. Voltmeter         | 0-600V             | 01       |         |
| 3.      | A.C. Ammeter           | 0-5A               | 01       |         |
| 4.      | A.C. Ammeter           | 0-5Amp             | 02       |         |
| 5.      | Rheostat               | 200 $\Omega$ , 5A  | 01       |         |
| 6.      | Capacitor              | 1.0 $\mu$ F / 400V | 01       |         |

**X Precautions:**

1. Discharge the capacitor before and after use.
2. Initially set the autotransformer to zero position.

**XI Procedure:**

1. Connect the circuit as shown in figure 4.1.
2. Switch on the supply.
3. Adjust the voltage to rated value by using autotransformer.
4. Record the values of V, I,  $I_R$  and  $I_C$  in table no. 1.
5. Take three readings by varying rheostat.
6. Reduce the voltage to zero and switch off the supply.
7. Calculate the values of circuit components i.e. resistance 'R', capacitive reactance ' $X_C$ ' (Neglect resistance of capacitor), capacitance 'C'.
8. Calculate admittance 'Y' and phase angle ' $\phi$ '.
9. Now calculate active, reactive and apparent power.

**XII Resources used (with major specifications):**

| S. No. | Instrument /Components | Specification | Quantity |
|--------|------------------------|---------------|----------|
| 1.     |                        |               |          |
| 2.     |                        |               |          |
| 3.     |                        |               |          |
| 4.     |                        |               |          |

**XIII Actual procedure followed:**

.....  
 .....  
 .....

**XIV Precautions followed:**

.....  
 .....  
 .....

**XV Observations and Calculations:**

**Table 1: Measurement of V and I and calculation of power**

| Sr. No | Measured |       |                    |                    | Calculated |                    |        |       |   |                  |                      |                     |
|--------|----------|-------|--------------------|--------------------|------------|--------------------|--------|-------|---|------------------|----------------------|---------------------|
|        | V (V)    | I (A) | I <sub>R</sub> (A) | I <sub>C</sub> (A) | R (Ω)      | X <sub>c</sub> (Ω) | C (μF) | Y (□) | φ | Active Power (W) | Reactive Power (VAr) | Apparent Power (VA) |
| 1      |          |       |                    |                    |            |                    |        |       |   |                  |                      |                     |
| 2      |          |       |                    |                    |            |                    |        |       |   |                  |                      |                     |
| 3      |          |       |                    |                    |            |                    |        |       |   |                  |                      |                     |

**Calculations:**

Calculate-

- $R = (V / I_R) \Omega$
- $X_C = (V / I_C) \Omega$
- $C = (1 / 2\pi f X_C) F$
- $Y = \sqrt{(1/R)^2 + (\omega C)^2} \square$
- $\phi = \tan^{-1} \omega C R$
- Active Power = ( V I cos φ ) W
- Reactive Power = ( V I sin φ ) VAr
- Apparent Power = ( V I ) VA

**Phasor diagrams:**

**For reading no.1**

**For reading no.2**

**For reading no.3**

**XVI Results**

1. Active Power = .....
2. Reactive Power = .....
3. Apparent Power = .....

**XVII Interpretation of results**

.....  
.....  
.....

**XVIII Conclusions and Recommendation**

.....  
.....  
.....

**XIX Practical related Questions**

1. How the selection of proper value of resistance is made for this experiment?
2. What is the effect if a variable capacitor is used instead of varying the resistance in the given circuit?

**[Space for Answers]**

.....  
.....  
.....  
.....



**XX References / Suggestions for further Reading**

1. Sudhakar A., PalliShyammohan - Circuit and network - Tata McGraw Hill, New Delhi, 2006 ISBN :978-0-07-340458-5 V.K. Mehta , Rohit Mehta - Basic Electrical Engineering - S. Chand Publication
- a. [www.cesim.com/simulations](http://www.cesim.com/simulations)
- b. [www.youtube.com /electric circuits](http://www.youtube.com/electric%20circuits)
- c. [www.dreamtechpress.com /ebooks](http://www.dreamtechpress.com/ebooks)
- d. [www.nptelvideos.in/electrical engineering/ circuit theory](http://www.nptelvideos.in/electrical%20engineering/circuit%20theory)
- e. [www.learnerstv.com/free-engineering](http://www.learnerstv.com/free-engineering)

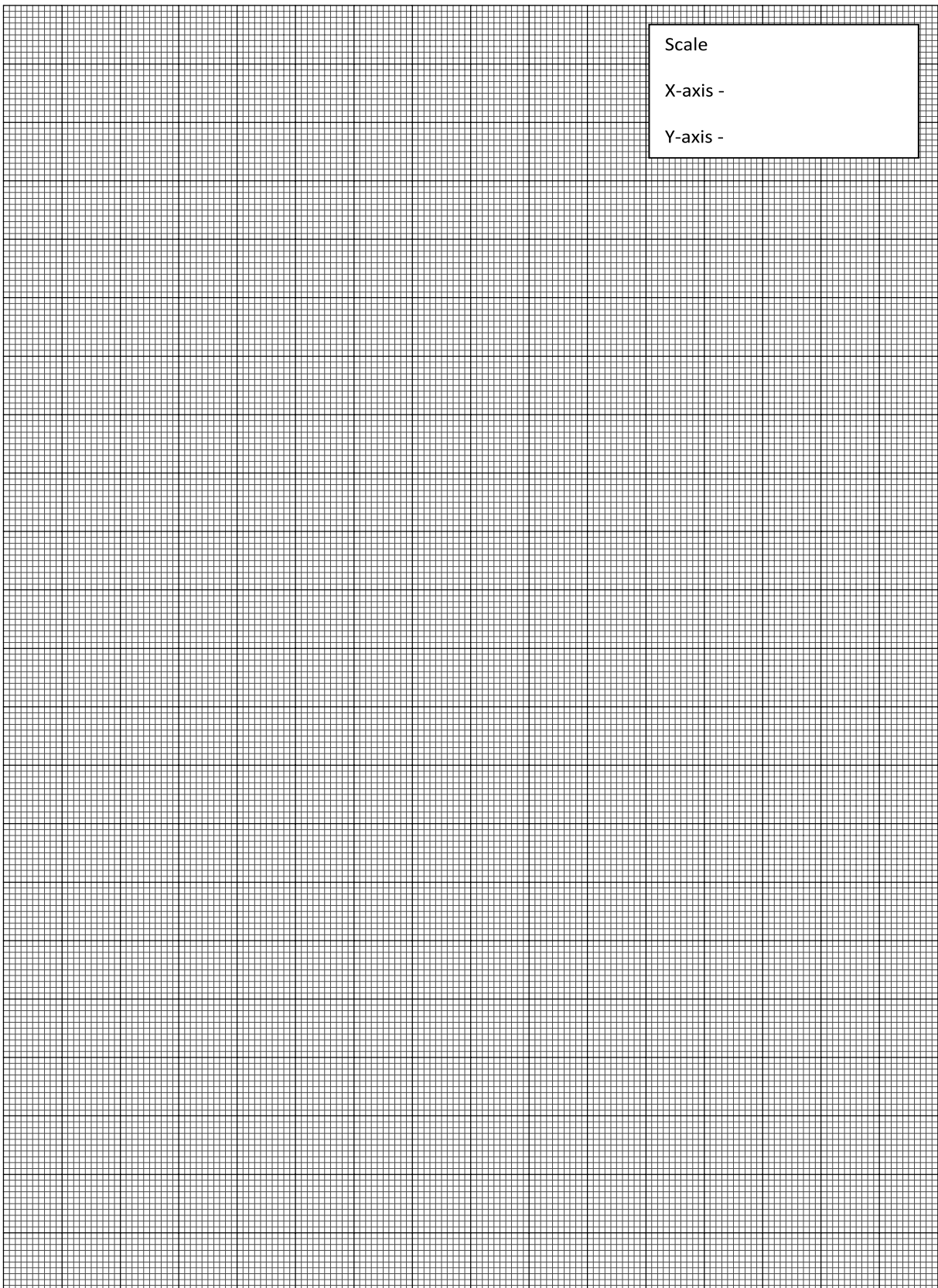
**XXI Assessment Scheme**

| Performance indicators            |   | Weightage    |
|-----------------------------------|---|--------------|
| <b>Process related (10 Marks)</b> |   | <b>40%</b>   |
| 1                                 | Selection of equipment, components, instruments | 10%          |
| 2                                 | Proper connection of circuit                    | 10%          |
| 3                                 | Neatness in the arrangement of circuit          | 10%          |
| 4                                 | Procedural steps followed                       | 10%          |
| <b>Product related (15 Marks)</b> |   | <b>60%</b>   |
| 5                                 | Accuracy in calculations                        | 20%          |
| 6                                 | Representation of phasor diagram                | 20%          |
| 7                                 | Interpretation of results                       | 10%          |
| 8                                 | Conclusion                                      | 05%          |
| 9                                 | Submitting the journal in time                  | 05%          |
| <b>Total (25 Marks)</b>           |   | <b>100 %</b> |

*Names of Student Team Members*

1. ....
2. ....
3. ....
4. ....

| Marks Obtained      |                     |            | Dated signature of Teacher |
|---------------------|---------------------|------------|----------------------------|
| Process Related(15) | Product Related(10) | Total (25) |                            |
|                     |                     |            |                            |





## Practical No.05: R-L-C Parallel Circuit

### I Practical Significance:

Parallel circuits are used more frequently in electrical systems than series circuits. Most of the applications requiring different currents at the same voltage are to be connected to the same power supply by connecting them in parallel. In industries majority of load is inductive, transmission lines also have R and L parameters, hence p.f. of such systems becomes low. This type of circuit is used to compensate the reactive power consumed by inductive load by connecting capacitor banks across R-L loads. By performing this practical you will be able to measure and interpret the active power, reactive power and apparent power consumed by the R-L-C parallel circuit.

### II Relevant Program Outcomes (POs)

1. **Discipline knowledge:** Apply knowledge of basic mathematics, sciences and basic engineering to solve the broad-based Digital Electronics/Industrial Electronics/Electronics & Telecommunication related problems.
2. **Experiments and practice:** Plan to perform experiments and practices to use the results to solve broad-based Digital Electronics/Industrial Electronics/Electronics & Telecommunication problems.
3. **Engineering tools:** Apply relevant Digital Electronics/Industrial Electronics/Electronics & Telecommunication technologies and tools with an understanding of the limitations.
4. **Individual and team work:** Function effectively as a leader and team member in diverse/ multidisciplinary teams.
5. **Communication:** Communicate effectively in oral and written form.

### III Competency and Practical Skills:

The aim of this course is to help the student to attain the following industry identified competency through various teaching learning experiences:

**Diagnose the electrical and electronic circuit problems.**

This practical is expected to develop the following skills in students.

1. Connect components and instruments in the circuits per the requirement.
2. Use Electrical equipment.
3. Use electrical measuring instruments.

### IV Relevant Course Outcomes:

Check the working of single phase A.C. circuits.

Apply the principles of resonance in electric / electronic circuits.

### V Practical Outcome:

- (i) Measure currents in R-L-C parallel A.C. circuit.
- (ii) Determine P.F. active, reactive and apparent power for given R-L-C parallel circuit with series connection of resistor and inductor in parallel with capacitor.

**VI Relevant Affective domain related Outcome(s):**

- Follow safe practices.
- Practice good housekeeping.
- Maintain tools and equipment.
- Demonstrate working as a leader / a team member.
- Observe step by step sequence of operations.

**VII Minimum Theoretical Background:**

If  $V$ (r.m.s.) is the applied voltage across the parallel R-L-C circuit with series connection of resistor and inductor in parallel with capacitor and  $I$ (r.m.s.) is the resultant current flowing through the circuit, then

Current flowing through series R-L branch =  $I_{RL}$ ..lags behind voltage by a phase angle  $\phi_1$ .

Current flowing through C =  $I_C$  .....leading  $90^\circ$  with voltage.

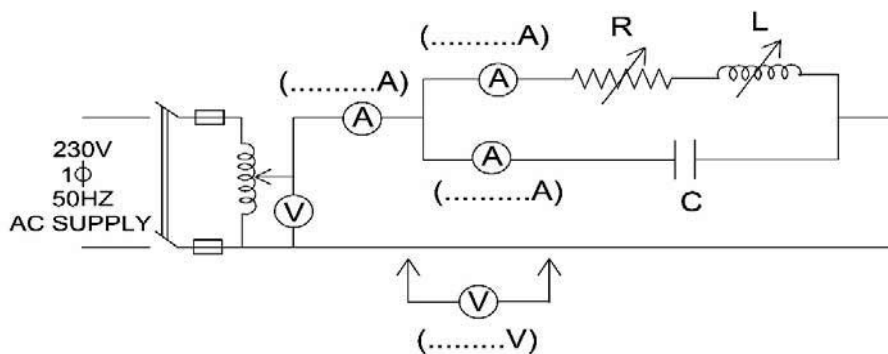
$$\vec{I} = \vec{I}_R + \vec{I}_C$$

$$\text{Phase angle, } \phi = \tan^{-1} \left[ R \left( \omega C - \frac{1}{\omega L} \right) \right]$$

Active Power (True Power)= $VI\cos\phi$ . This power is measured in watts.

Reactive Power= $VI\sin\phi$ . This power is measured in VAR.

Apparent Power= $VI$ . This power is measured in VA.

**VIII Practical Circuit Diagram:****a) Sample**

(Note voltmeter must be connected across each components)

**Figure 5.1**

**b) Actual Circuit / Experimental set up used in laboratory:****IX Resources required:**

Following Table Format Should be Single Line

| Sr. No. | Instrument /Components | Specification      | Quantity | Remarks |
|---------|------------------------|--------------------|----------|---------|
| 1.      | Autotransformer        | Single phase, 1kVA | 01       |         |
| 2.      | A.C. Voltmeter         | 0 -600 V MI type   | 01       |         |
| 3.      | A.C. Ammeter           | 0-10 Amp           | 01       |         |
| 4.      | A.C. Ammeter           | 0 -5 Amp           | 02       |         |
| 5.      | Rheostat               | 200 $\Omega$ , 5A  | 01       |         |
| 6.      | Inductor               | 100mH              | 01       |         |
| 7.      | Capacitor              | 1 $\mu$ F / 400V   | 01       |         |

**X Precautions:**

1. Discharge the capacitor before and after use.
2. Initially set the autotransformer to zero position.

**XI Procedure:**

1. Connect the circuit as shown in figure 5.1.
2. Switch on the supply.
3. Adjust the voltage to rated value by using autotransformer.
4. Record the values of V,  $V_R$ ,  $V_L$ , I,  $I_{RL}$  and  $I_C$  in table no. 1.
5. Take three readings either by varying the resistor or the inductor.
6. Reduce the voltage to zero and switch off the supply.
7. Calculate the values of circuit components i.e. resistance 'R', inductive reactance ' $X_L$ ' (Neglect resistance of inductor), inductance 'L', capacitive reactance ' $X_C$ ' (Neglect resistance of capacitor), capacitance 'C'.
8. Calculate admittance 'Y' and phase angle ' $\phi$ '.
9. Now calculate active, reactive and apparent power.

**XII Resources used (with major specifications):**

| S. No. | Instrument /Components | Specification | Quantity |
|--------|------------------------|---------------|----------|
| 1      |                        |               |          |
| 2      |                        |               |          |
| 3      |                        |               |          |
| 4      |                        |               |          |
| 5      |                        |               |          |

**XIII Actual procedure followed:**

.....  
 .....  
 .....

**XIV Precautions followed:**

.....  
 .....  
 .....

**XV Observations and Calculations:**

**Table 1: Measurement of V and I and calculation of power**

| Sr. No | Measured |                    |                    |       |                     |                    | Calculated |                    |       |                    |        |       |   |                  |                      |                     |
|--------|----------|--------------------|--------------------|-------|---------------------|--------------------|------------|--------------------|-------|--------------------|--------|-------|---|------------------|----------------------|---------------------|
|        | V (V)    | V <sub>R</sub> (V) | V <sub>L</sub> (V) | I (A) | I <sub>RL</sub> (A) | I <sub>C</sub> (A) | R (Ω)      | X <sub>L</sub> (Ω) | L (H) | X <sub>C</sub> (Ω) | C (μF) | Y (□) | φ | Active Power (W) | Reactive Power (VAr) | Apparent Power (VA) |
| 1      |          |                    |                    |       |                     |                    |            |                    |       |                    |        |       |   |                  |                      |                     |
| 2      |          |                    |                    |       |                     |                    |            |                    |       |                    |        |       |   |                  |                      |                     |
| 3      |          |                    |                    |       |                     |                    |            |                    |       |                    |        |       |   |                  |                      |                     |

**Calculations:**

Calculate-

- $R = (V / I_{RL}) \Omega$
- $X_L = (V / I_{RL}) \Omega$
- $L = (X_L / 2\pi f) H$
- $X_C = (V / I_C) \Omega$
- $C = (1 / 2\pi f X_C) F$
- $Y = \sqrt{(1/R)^2 + (\omega C - \frac{1}{\omega L})^2} \square$

7.  $\phi = \tan^{-1}\left[R\left(\omega C - \frac{1}{\omega L}\right)\right]$

8. Active Power = ( VIcos $\phi$  ) W

9. Reactive Power = ( VI sin $\phi$  ) VAR

10. Apparent Power = ( VI ) VA

**XVI Results**

- 1. Active Power = .....
- 2. Reactive Power = .....
- 3. Apparent Power = .....

**XVII Interpretation of results**

.....  
.....  
.....

**XVIII Conclusions and Recommendation**

.....  
.....  
.....

**XIX Practical related Questions**

- 1. How the selection of proper value of resistance is made for this experiment?
- 2. What is the effect on the p.f. of the circuit when-
  - a. Only resistance is varied and inductor is kept fixed.
  - b. Only inductor is varied and resistance is kept fixed.
  - c. Both resistance and inductor are varied.

**[Space for Answers]**

.....  
.....  
.....  
.....  
.....  
.....  
.....  
.....  
.....  
.....  
.....

**XX References / Suggestions for further Reading**

Sudhakar A., PalliShyammoan - Circuit and network - Tata McGraw Hill, New Delhi, 2006 ISBN :978-0-07-340458-5

V.K. Mehta ,Rohit Mehta - Basic Electrical Engineering - S. Chand Publication

- a. www.cesim.com/simulations
- b. www.youtube.com /electric circuits
- c. www.dreamtechpress.com /ebooks
- d. www.nptelvideos.in/electrical engineering/ circuit theory
- e. www.learnerstv.com/free-engineering

**XXI Assessment Scheme**

| Performance indicators            |   | Weightage    |
|-----------------------------------|---|--------------|
| <b>Process related (10 Marks)</b> |   | <b>40%</b>   |
| 1                                 | Selection of equipment, components, instruments | 10%          |
| 2                                 | Proper connection of circuit                    | 10%          |
| 3                                 | Neatness in the arrangement of circuit          | 10%          |
| 4                                 | Procedural steps followed                       | 10%          |
| <b>Product related (15 Marks)</b> |   | <b>60%</b>   |
| 5                                 | Accuracy in calculations                        | 20%          |
| 6                                 | Representation of phase diagram                 | 20%          |
| 7                                 | Interpretation of results                       | 10%          |
| 8                                 | Conclusion                                      | 05%          |
| 9                                 | Submitting the journal in time                  | 05%          |
| <b>Total (25 Marks)</b>           |   | <b>100 %</b> |

**Names of Student Team Members**

1. ....
2. ....
3. ....
4. ....

| Marks Obtained         |                        |               | Dated signature of<br>Teacher |
|------------------------|------------------------|---------------|-------------------------------|
| Process<br>Related(15) | Product<br>Related(10) | Total<br>(25) |                               |
|                        |                        |               |                               |

## **Practical No.06: Initial and Final condition across the capacitor**

### **I Practical Significance:**

Capacitors are the important components in the electronics circuits. It is very important to know the response of the capacitor before switching and after switching instant which helps in designing electronic circuits.

### **II Relevant Program Outcomes (POs)**

- **Discipline knowledge:** Apply knowledge of basic mathematics, sciences and basic engineering to solve the broad-based Digital Electronics/Industrial Electronics/ Electronics & Telecommunication related problems.
- **Experiments and practice:** Plan to perform experiments and practices to use the results to solve broad-based Digital Electronics/Industrial Electronics/Electronics & Telecommunication problems.
- **Engineering tools:** Apply relevant Digital Electronics/Industrial & Electronics /Electronics Telecommunication technologies and tools with an understanding of the limitations.

### **III Competency and Practical Skills**

The aim of this course is to help the student to attain the following industry identified Competency through various teaching learning experiences:

#### **Diagnose the electrical and electronic circuit problems.**

This practical is expected to develop the following skills in students.

1. Identify Electrical & Electronic components
2. Use electrical & electronic measuring instruments
3. Measure electrical quantities in various systems
4. Use of Capacitor Response in designing circuits

### **IV Relevant Course Outcomes:**

Use of capacitors in single phase A.C circuits

### **V Practical Outcome:**

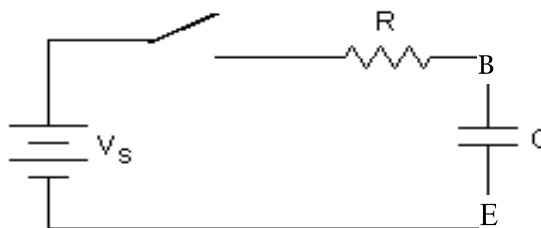
Determine initial and final voltage across the capacitor at  $t=0^-$  and  $t=0^+$

### **VI Relevant Affective domain related Outcome(s)**

- a. Practice good housekeeping
- b. Maintain tools and equipment properly

**VII Minimum Theoretical Background**

Before Switching at  $t=0^-$  Capacitor acts as a Short circuit and after switching at  $t = 0^+$  due to flow of current capacitor charges to a voltage and appears as open circuit.

**VIII Practical Circuit Diagram :****a) Sample****Figure 6. 1****b) Actual Circuit / Experimental set up used in laboratory****IX Resources required**

| S. No. | Instrument /Components | Specification                  | Quantity | Remarks |
|--------|------------------------|--------------------------------|----------|---------|
| 1.     | Resistances            | Suitable value                 | 1        |         |
| 2.     | Capacitor              | Non Polarity of suitable value | 1        |         |
| 3.     | Bread board            |                                | 1        |         |
| 4.     | Ammeter                | Suitable range                 | 1        |         |
| 5.     | Voltage source         | D C power supply 0-30 V 1 Amp  | 1        |         |
| 6.     | DSO                    | DSO CURRENT PROBE              | 1        |         |



**X Precautions**

1. Check the connection before connecting circuit to supply
2. Apply voltage as per rating of the resistor & capacitor series combination

**XI Procedure**

1. Identify the component as per the resources required
2. Connect the circuit as shown in figure
3. Switch on the supply
4. Read & note the Voltage across capacitor before switching and after switching.
5. Measure Current and voltage using DSO
6. Switch off the supply.

**XII Resources used (with major specifications)**

| S. No. | Instrument /Components | Specification | Quantity |
|--------|------------------------|---------------|----------|
| 1.     |                        |               |          |
| 2.     |                        |               |          |
| 3.     |                        |               |          |
| 4.     |                        |               |          |
| 5.     |                        |               |          |

**XIII Actual procedure followed**

.....

.....

.....

.....

.....

.....

.....

.....

**XIV Precautions followed**

.....

.....

.....

.....

.....

.....

.....

**XV Observations and Calculations:**

**Table 1: Observed and Calculated value of current through branch BE**

| Sr. No. | Observed Vc | Calculated Vc | Current In Amp |            |
|---------|-------------|---------------|----------------|------------|
|         |             |               | Observed       | Calculated |
| 1       |             |               |                |            |
| 2       |             |               |                |            |

**Calculations:** Write the voltage equation for the capacitor

**XVI Results**

1. Voltage across capacitor at  $t = 0^-$  .....
2. Voltage across capacitor at  $t = 0^+$  .....

**XVII Interpretation of Results**

.....  
 .....  
 .....

**XVIII Conclusions and Recommendation**

.....  
 .....  
 .....

**XIX Practical related Questions**

1. How does capacitor acts before switching and after switching.
2. Can we perform the experiment using DC supply? Justify your answer.

**[Space for Answers]**

.....  
 .....  
 .....  
 .....  
 .....  
 .....  
 .....  
 .....  
 .....  
 .....



**XX References / Suggestions for further Reading-**

Author: V.K. MEHTA, ROHIT MEHTA, Title: Basic Electrical Engineering, Publisher: S. Chand & Co.

**XXI Assessment Scheme**

| <b>Performance indicators</b>     |   | <b>Weightage</b> |
|-----------------------------------|---|------------------|
| <b>Process related (10 Marks)</b> |   | <b>40%</b>       |
| 1                                 | Selection of equipment, components, instruments | 10%              |
| 2                                 | Proper connection of circuit                    | 10%              |
| 3                                 | Neatness in the arrangement of circuit          | 10%              |
| 4                                 | Procedural steps followed                       | 10%              |
| <b>Product related (15 Marks)</b> |   | <b>60%</b>       |
| 5                                 | Accuracy in calculations                        | 20%              |
| 6                                 | Representation of phase diagram                 | 20%              |
| 7                                 | Interpretation of results                       | 10%              |
| 8                                 | Conclusion                                      | 05%              |
| 9                                 | Submitting the journal in time                  | 05%              |
| <b>Total (25 Marks)</b>           |   | <b>100 %</b>     |

*Names of Student Team Members*

1. ....
2. ....
3. ....
4. ....

| <b>Marks Obtained</b>      |                            |                   | <b>Dated signature of Teacher</b> |
|----------------------------|----------------------------|-------------------|-----------------------------------|
| <b>Process Related(15)</b> | <b>Product Related(10)</b> | <b>Total (25)</b> |                                   |
|                            |                            |                   |                                   |

## Practical No.07: Initial and final condition in inductor

### I Practical Significance:

Inductors are the important components in the electronics circuits. It is very important to know the response of the Inductor before switching and after switching instant which helps in designing electronic circuits.

### II Relevant Program Outcomes (POs)

- **Discipline knowledge:** Apply knowledge of basic mathematics, sciences and basic engineering to solve the broad-based Digital Electronics/Industrial Electronics/Electronics & Telecommunication related problems.
- **Experiments and practice:** Plan to perform experiments and practices to use the results to solve broad-based Digital Electronics/Industrial Electronics/Electronics & Telecommunication problems.
- **Engineering tools:** Apply relevant Digital Electronics/Industrial Electronics/Electronics & Telecommunication technologies and tools with an understanding of the limitations.

### III Competency and Practical Skills

The aim of this course is to help the student to attain the following industry identified Competency through various teaching learning experiences:

**Diagnose the electrical and electronic circuit problems.**

This practical is expected to develop the following skills in students.

1. Identify Electrical & Electronic components
2. Use electrical & electronic measuring instruments
3. Measure electrical quantities in various systems
4. Use of inductor response in designing the electronic circuits

### IV Relevant Course Outcomes:

Use of inductors/Capacitor in DC circuits.

### V Practical Outcome:

Determine initial and final current through the inductive coil at  $t = 0^-$  and at  $t = 0^+$

### VI Relevant Affective domain related Outcome(s)

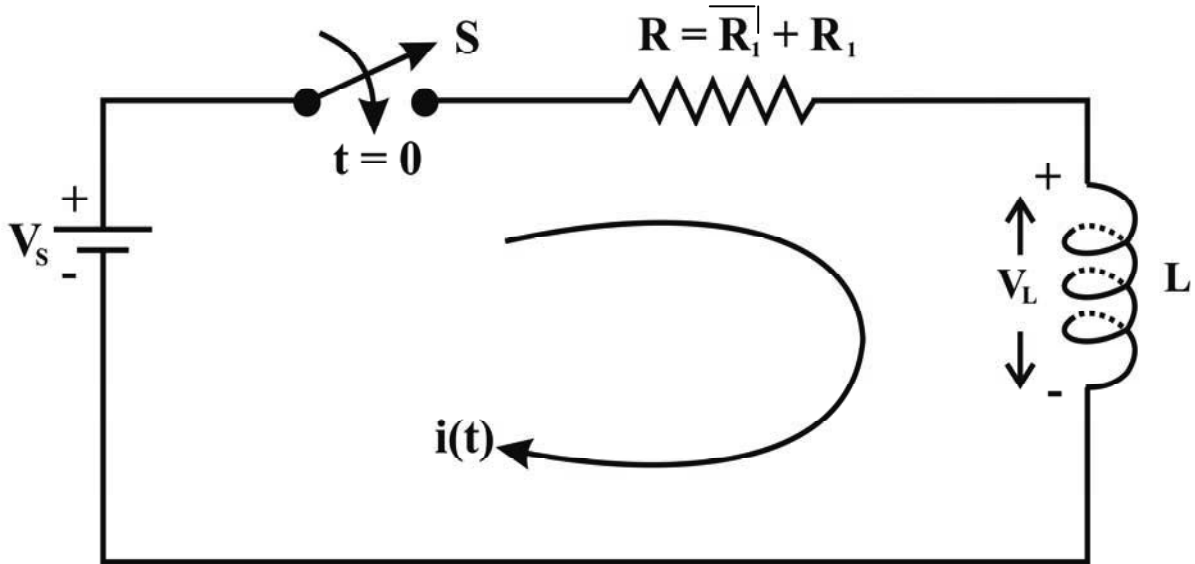
- a. Practice good housekeeping
- b. Maintain tools and equipment properly

### VII Minimum Theoretical Background

Before Switching at  $t=0^-$  Inductor acts as a open circuit and after switching at  $t = 0^+$  due to flow of current inductor appears as short circuit.

**VIII Practical Circuit Diagram :**

**a) Sample**



**Figure 1: FOR transient DC Source should used**

**b) Actual Circuit / Experimental set up used in laboratory**

**IX Resources required:**

| S. No. | Instrument /Components | Specification | Quantity | Remarks |
|--------|------------------------|---------------|----------|---------|
| 1.     | Resistance             | 1K -10 K Ohm  | 1        |         |
| 2.     | Inductor               | 100mH         | 1        |         |
| 3.     | Bread board            |               | 1        |         |
| 4.     | Ammeter                | 0-1 Amp DC    | 1        |         |
| 5.     | Voltage source         | 0-30 V 1 Amp  | 1        |         |
| 6.     | DSO                    | Current probe | 1        |         |

**X Precautions:**

1. Check the connection before connecting circuit to supply
2. Apply voltage as per rating of the resistor & inductor series combination

**XI Procedure**

1. Identify the component as per the resources required
2. Connect the circuit as shown in figure
3. Switch on the supply
4. Read & note the current value.
5. Switch off the supply

**XII Resources used (with major specifications)**

| S. No. | Instrument /Components | Specification | Quantity |
|--------|------------------------|---------------|----------|
| 1.     |                        |               |          |
| 2.     |                        |               |          |
| 3.     |                        |               |          |
| 4.     |                        |               |          |
| 5.     |                        |               |          |

**XIII Actual procedure followed**

.....  
.....  
.....  
.....  
.....  
.....  
.....  
.....

**XIV Precautions followed**

.....  
.....  
.....  
.....  
.....  
.....  
.....

**XV Observations and Calculations:**

**Table 1: Observed and Calculated value of current through branch BE**

| <b>Sr. No.</b> | <b>Observed<br/><math>I_L</math></b> | <b>Calculated<br/><math>I_L</math></b> |
|----------------|--------------------------------------|--|
| 1              |                                      |  |
| 2              |                                      |  |

**Calculations:** Write the current equation for the inductor.

**XVI Results**

1. Observed value of current through inductor = .....
2. Calculated value of current through inductor = .....

**XVII Interpretation of results**

.....  
.....  
.....

**XVIII Conclusions and Recommendation**

.....  
.....  
.....

**XIX Practical related Questions**

1. How does inductor acts before switching and after switching.
2. Can we perform the experiment using AC supply? Justify your answer.

**[Space for Answers]**

.....  
.....  
.....  
.....  
.....  
.....  
.....  
.....  
.....



.....

.....

.....

.....

.....

.....

**XX References / Suggestions for further Reading**

Author: V.K. MEHTA, ROHIT MEHTA, Title: Basic Electrical Engineering, Publisher: S. Chand & Co.

**XXI Assessment Scheme-**

| Performance indicators            |   | Weightage    |
|-----------------------------------|---|--------------|
| <b>Process related (10 Marks)</b> |   | <b>40%</b>   |
| 1                                 | Selection of equipment, components, instruments | 10%          |
| 2                                 | Proper connection of circuit                    | 10%          |
| 3                                 | Neatness in the arrangement of circuit          | 10%          |
| 4                                 | Procedural steps followed                       | 10%          |
| <b>Product related (15 Marks)</b> |   | <b>60%</b>   |
| 5                                 | Accuracy in calculations                        | 20%          |
| 6                                 | Representation of phasor diagram                | 20%          |
| 7                                 | Interpretation of results                       | 10%          |
| 8                                 | Conclusion                                      | 05%          |
| 9                                 | Submitting the journal in time                  | 05%          |
| <b>Total (25 Marks)</b>           |   | <b>100 %</b> |

***Names of Student Team Members***

1. ....
2. ....
3. ....
4. ....

| Marks Obtained      |                     |            | Dated signature of Teacher |
|---------------------|---------------------|------------|----------------------------|
| Process Related(15) | Product Related(10) | Total (25) |                            |
|                     |                     |            |                            |

## Practical No.08: Resonance in R-L-C Circuit

### I Practical Significance:

Concept of Resonance is used in tuning the Electronic communication circuits. concept of resonance is used in troubleshooting and designing the electronic communication circuit

### II Relevant Program Outcomes (POs)

- **Discipline knowledge:** Apply knowledge of basic mathematics, sciences and basic engineering to solve the broad-based Digital Electronics/Industrial Electronics/Electronics & Telecommunication related problems.
- **Experiments and practice:** Plan to perform experiments and practices to use the results to solve broad-based Digital Electronics/Industrial Electronics/Electronics & Telecommunication problems.
- **Engineering tools:** Apply relevant Digital Electronics/Industrial Electronics/Electronics & Telecommunication technologies and tools with an understanding of the limitations.

### III Competency and Practical Skills

The aim of this course is to help the student to attain the following industry identified Competency through various teaching learning experiences:

**Diagnose the electrical and electronic circuit problems.**

This practical is expected to develop the following skills in students.

1. Identify Electrical & Electronic components
2. Use electrical & electronic measuring instruments
3. Measure electrical quantities in various systems

### IV Relevant Course Outcomes:

Use the concept of resonance in tuning the electronic communication circuits.

### V Practical Outcome:

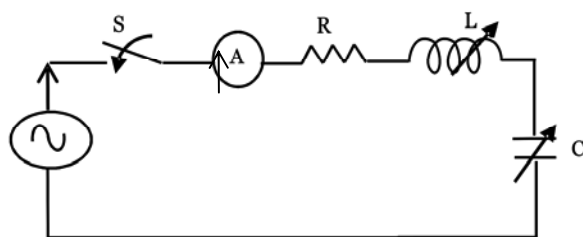
Create Resonance in given R-L-C circuit by varying L and C or by using variable frequency supply.

### VI Relevant Affective domain related Outcome(s)

- a. Practice good housekeeping
- b. Maintain tools and equipment properly

### VII Minimum Theoretical Background

In this method resonance occurs when the capacitive reactance and the inductive reactance becomes equal. The circuit becomes resistive and there is voltage magnification in series circuit and current magnification in parallel circuit.

**VIII Practical Circuit Diagram :****a) Sample****Figure 8.1:****b) Actual Circuit / Experimental set up used in laboratory****IX Resources required:**

| S. No. | Instrument /Components | Specification                 | Quantity | Remarks |
|--------|------------------------|-------------------------------|----------|---------|
| 1.     | Resistances            | Suitable Value                | 1        |         |
| 2.     | Capacitor              | Suitable Value variable       | 1        |         |
| 3.     | Inductor               | Suitable Value variable       | 1        |         |
| 4.     | Bread board            |                               | 1        |         |
| 5.     | Ammeter                | Suitable Range                | 1        |         |
| 6.     | Function generator     | 2 Mhz with variable amplitude | 1        |         |

**X Precautions:**

1. Check the connection before connecting circuit to supply
2. Apply voltage as per rating of the resistor & inductor series combination

**XI Procedure -**

1. Identify the component as per the resources required
2. Connect the circuit as shown in figure
3. Switch on the supply
4. Read & note the current value.
5. Switch off the supply

**XII Resources used (with major specifications)**

| S. No. | Instrument /Components | Specification | Quantity |
|--------|------------------------|---------------|----------|
| 1.     |                        |               |          |
| 2.     |                        |               |          |
| 3.     |                        |               |          |
| 4.     |                        |               |          |
| 5.     |                        |               |          |

**XIII Actual procedure followed**

.....  
 .....  
 .....

**XIV Precautions followed**

.....  
 .....  
 .....

**XV Observations and Calculations:**

**Table 8.1: Observed and Calculated value of current at Resonance**

| Sr. No. | Observed Value of current I | Frequency | Xc | X <sub>L</sub> | $Z = \sqrt{R^2 + (X_c - X_L)^2}$ | Calculated value of current I = V/Z |
|---------|-----------------------------|-----------|----|----------------|----------------------------------|-------------------------------------|
| 1       |                             |           |    |                |                                  |                                     |
| 2       |                             |           |    |                |                                  |                                     |
| 3       |                             |           |    |                |                                  |                                     |
| 4       |                             |           |    |                |                                  |                                     |
| 5       |                             |           |    |                |                                  |                                     |
| 6       |                             |           |    |                |                                  |                                     |
| 7       |                             |           |    |                |                                  |                                     |
| 8       |                             |           |    |                |                                  |                                     |
| 9       |                             |           |    |                |                                  |                                     |
| 10      |                             |           |    |                |                                  |                                     |

**Calculations:** Calculate the values of capacitive reactance and Inductive Reactance, Voltage and current at resonance.



.....

.....

.....

.....

.....

.....

**XX References / Suggestions for further Reading**

Author: V.K. MEHTA, ROHIT MEHTA, Title: Basic Electrical Engineering, Publisher: S. Chand & Co.

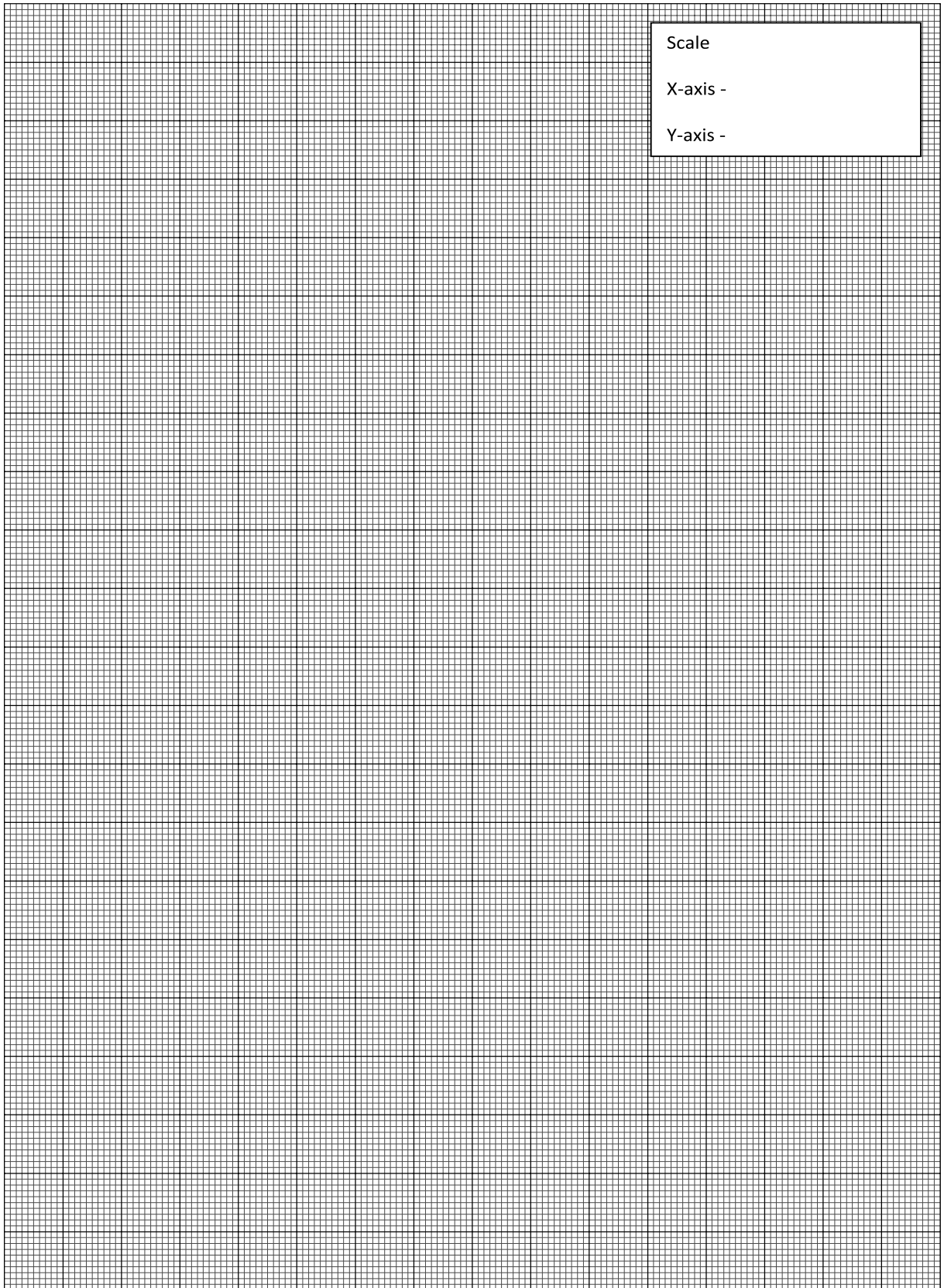
**XXI Assessment Scheme-**

| Performance indicators            |   | Weightage    |
|-----------------------------------|---|--------------|
| <b>Process related (10 Marks)</b> |   | <b>40%</b>   |
| 1                                 | Selection of equipment, components, instruments | 10%          |
| 2                                 | Proper connection of circuit                    | 10%          |
| 3                                 | Neatness in the arrangement of circuit          | 10%          |
| 4                                 | Procedural steps followed                       | 10%          |
| <b>Product related (15 Marks)</b> |   | <b>60%</b>   |
| 5                                 | Accuracy in calculations                        | 20%          |
| 6                                 | Representation of phasor diagram                | 20%          |
| 7                                 | Interpretation of results                       | 10%          |
| 8                                 | Conclusion                                      | 05%          |
| 9                                 | Submitting the journal in time                  | 05%          |
| <b>Total (25 Marks)</b>           |   | <b>100 %</b> |

***Names of Student Team Members***

1. ....
2. ....
3. ....
4. ....

| Marks Obtained      |                     |            | Dated signature of Teacher |
|---------------------|---------------------|------------|----------------------------|
| Process Related(15) | Product Related(10) | Total (25) |                            |
|                     |                     |            |                            |



## Practical No.09: Mesh Analysis

### I Practical Significance:

The Electrical & Electronic circuit for different systems involves a number of branches. Many a times as per the requirement, measurement of current, voltage & power across a branch is required. These parameters can be calculated using Mesh Analysis of the given circuit. This experiment will help you to verify the theoretically obtained current through a branch using mesh analysis.

### II Relevant Program Outcomes (POs)

- **Discipline knowledge:** Apply knowledge of basic mathematics, sciences and basic engineering to solve the broad-based Digital Electronics/Industrial Electronics/Electronics & Telecommunication related problems.
- **Experiments and practice:** Plan to perform experiments and practices to use the results to solve broad-based Digital Electronics/Industrial Electronics/Electronics & Telecommunication problems.
- **Engineering tools:** Apply relevant Digital Electronics/Industrial Electronics/Electronics & Telecommunication technologies and tools with an understanding of the limitations.

### III Competency and Practical Skills

The aim of this course is to help the student to attain the following industry identified Competency through various teaching learning experiences:

**Diagnose the electrical and electronic circuit problems.**

This practical is expected to develop the following skills in students.

1. Identify Electrical & Electronic components
2. Use electrical & electronic measuring instruments
3. Measure electrical quantities in various systems

### IV Relevant Course Outcomes:

Use the principles of circuit analysis to check the functionality

### V Practical Outcome:

Determine current through given branch of a electrical network by applying mesh analysis

### VI Relevant Affective domain related Outcome(s)

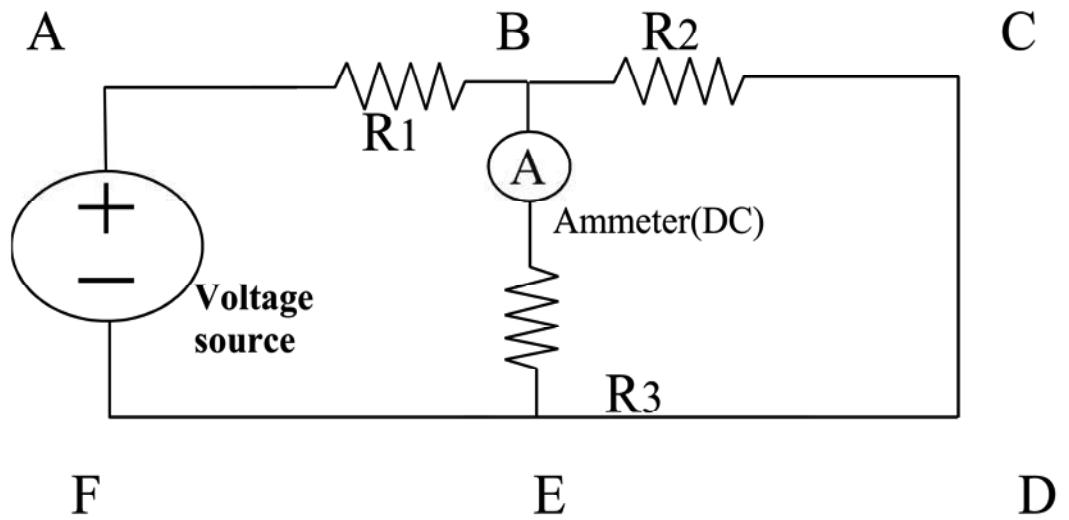
- a. Practice good housekeeping
- b. Maintain tools and equipment properly

### VII Minimum Theoretical Background

In this method of analysis, Kirchhoff's Voltage Law is applied to a network to write mesh equations in terms of mesh currents. By solving simultaneous linear equations for multiple meshes, current through particular branch can be found out.



**VIII Practical Circuit Diagram :**  
**a) Sample**



( Ammeter should be connected in each branch )

**Figure 9.1:**

**b) Actual Circuit / Experimental set up used in laboratory**

**IX Resources required:**

| S. No. | Instrument /Components | Specification                                 | Quantity | Remarks |
|--------|------------------------|---|----------|---------|
| 1.     | Resistances            | 0 -100ohm                                     | 3        |         |
| 2.     | Bread board            |   | 1        |         |
| 3.     | Ammeter                | meter range depend on resistance value} 1 Amp | 1        |         |
| 4.     | Voltage source         | 0 -30 V 1 Amp                                 | 2        |         |

**X Precautions:**

1. Check the connection before connecting circuit to supply
2. Apply voltage as per rating of the resistor & inductor series combination

**XI Procedure**

1. Identify the component as per the resources required
2. Connect the circuit as shown in figure
3. Switch on the supply
4. Read & note the current value.
5. Switch off the supply

**XII Resources used (with major specifications)**

| S. No. | Instrument /Components | Specification | Quantity |
|--------|------------------------|---------------|----------|
| 1.     |                        |               |          |
| 2.     |                        |               |          |
| 3.     |                        |               |          |
| 4.     |                        |               |          |
| 5.     |                        |               |          |

**XIII Actual procedure followed**

.....

.....

.....

.....

.....

.....

.....

.....

.....

.....

.....

**XIV Precautions followed**

.....

.....

.....

.....

.....

.....

.....

.....

.....

.....

**XV Observations and Calculations:-**

**Table 9.1: Observed and Calculated value of current through branch BE**

| Sr. No. | Observed<br>$I_{BE(A)}$ | Calculated<br>$I_{BE(A)}$ |
|---------|-------------------------|---------------------------|
| 1       |                         |                           |
| 2       |                         |                           |

**Calculations:** Write Kirchhoff's Voltage Equations for the meshes. Simplify the equations. Write the equations in matrix form and find the values of mesh currents. Current through the branch BE is the difference between mesh current 1 and mesh current 2

**XVI Results**

1. Observed value of current through branch BE = .....
2. Calculated value of current through branch BE = .....

**XVII Interpretation of results**

.....  
 .....  
 .....

**XVIII Conclusions & Recommendation**

.....  
 .....  
 .....

**XIX Practical related Questions**

1. Show meshes in the circuit connection
2. Can we perform the experiment using AC supply? Justify your answer.

**[Space for Answers]**

.....  
 .....  
 .....  
 .....  
 .....  
 .....

.....

.....

.....

.....

.....

.....

.....

**XX References / Suggestions for further Reading**

Author: V.K. MEHTA, ROHIT MEHTA, Title: Basic Electrical Engineering, Publisher: S. Chand & Co.

**XXI Assessment Scheme**

| Performance indicators            |   | Weightage    |
|-----------------------------------|---|--------------|
| <b>Process related (10 Marks)</b> |   | <b>40%</b>   |
| 1                                 | Selection of equipment, components, instruments | 10%          |
| 2                                 | Proper connection of circuit                    | 10%          |
| 3                                 | Neatness in the arrangement of circuit          | 10%          |
| 4                                 | Procedural steps followed                       | 10%          |
| <b>Product related (15 Marks)</b> |   | <b>60%</b>   |
| 5                                 | Accuracy in calculations                        | 20%          |
| 6                                 | Representation of phase diagram                 | 20%          |
| 7                                 | Interpretation of results                       | 10%          |
| 8                                 | Conclusion                                      | 05%          |
| 9                                 | Submitting the journal in time                  | 05%          |
| <b>Total (25 Marks)</b>           |   | <b>100 %</b> |

***Names of Student Team Members***

1. ....
2. ....
3. ....
4. ....

| Marks Obtained      |                     |            | Dated signature of Teacher |
|---------------------|---------------------|------------|----------------------------|
| Process Related(15) | Product Related(10) | Total (25) |                            |
|                     |                     |            |                            |

## Practical No.10: Nodal Analysis

### I **Practical Significance:**

The Electrical and Electronic circuits in industrial applications involve a number of branches. Many a times current, power & voltage across a branch is required. It can be found out by using Nodal Analysis.

### II **Relevant Program Outcomes (POs)**

- **Discipline knowledge:** Apply knowledge of basic mathematics, sciences and basic engineering to solve the broad-based Digital Electronics/Industrial Electronics/Electronics & Telecommunication related problems.
- **Experiments and practice:** Plan to perform experiments and practices to use the results to solve broad-based Digital Electronics/Industrial Electronics/Electronics & Telecommunication problems.
- **Engineering tools:** Apply relevant Digital Electronics/Industrial Electronics/Electronics & Telecommunication technologies and tools with an understanding of the limitations.

### III **Competency and Practical Skills**

The aim of this course is to help the student to attain the following industry identified Competency through various teaching learning experiences:

#### **Maintain the electrical and electronic circuit.**

This practical is expected to develop the following skills in students.

1. Identify Electrical & Electronic components
2. Use Digital multimeter, ammeter, to measure the voltage, current
3. Calculate & compare voltage values

### IV **Relevant Course Outcomes:**

Use the principles of circuit analysis to check the functionality

### V **Practical Outcome:**

Determine voltage at the particular node and current through any given branch of the network by applying nodal analysis.

### VI **Relevant Affective domain related Outcome(s)**

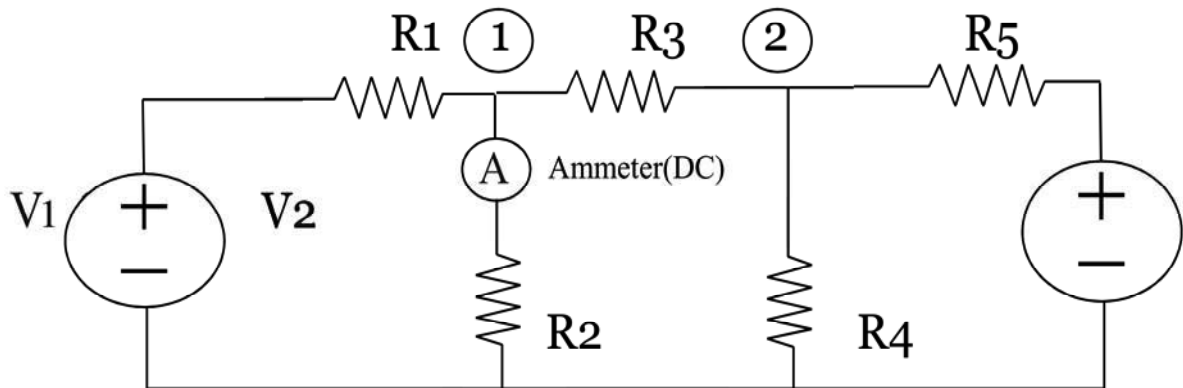
- a. Practice good housekeeping
- b. Maintain tools and equipment
- c. Observe step by step sequence of operations.

### VII **Minimum Theoretical Background**

In this method of analysis, Kirchhoff's Current Law is applied to a network to write nodal equations in terms of nodal voltages. By solving simultaneous linear equations for multiple nodes, voltage at particular node can be found out

**VIII Practical Circuit Diagram :**

**a) Sample**



(Ammeter should be connected in each branch )

**Figure 10.1**

**b) Actual Circuit / Experimental set up used in laboratory**

**IX Resources required**

Following Table Format Should be Single Line

| S. No. | Instrument /Components | Specification                                   | Quantity | Remarks |
|--------|------------------------|---|----------|---------|
| 1.     | Resistances            | 0 -100ohm                                       | 3        |         |
| 2.     | Bread board            |   | 1        |         |
| 3.     | Ammeter                | ( Meter range depend on resistance value} 1 Amp | 1        |         |
| 4.     | Voltage source         | 0 -30 V 1 Amp                                   | 2        |         |

**X Precautions**

1. Keep the resistances at maximum position
2. Check the connection before connecting circuit to supply
3. Apply voltage as per rating of the resistors, ammeter

**XI Procedure**

1. Connect the circuit as shown in figure
2. Switch on the supply
3. Read voltage values at nodes1 & node 2
4. Switch off the supply

**XII Resources used (with major specifications)**

| S. No. | Instrument /Components | Specification | Quantity |
|--------|------------------------|---------------|----------|
| 1.     |                        |               |          |
| 2.     |                        |               |          |
| 3.     |                        |               |          |
| 4.     |                        |               |          |
| 5.     |                        |               |          |

**XIII Actual procedure followed**

.....

.....

.....

.....

.....

.....

.....

.....

**XIV Precautions followed**

.....  
 .....  
 .....

**XV Observations and Calculations:**

**Table 10.1: Observed and Calculated value of voltage at node1 and node 2**

| Sr. No. | Observed $V_1(V)$ | Calculated $V_1(V)$ | Observed $V_2 (V)$ | Calculated $V_2 (V)$ | Current through $R_3$ |            |
|---------|-------------------|---------------------|--------------------|----------------------|-----------------------|------------|
|         |                   |                     |                    |                      | Observed              | Calculated |
| 1       |                   |                     |                    |                      |                       |            |
| 2       |                   |                     |                    |                      |                       |            |

**Calculations:** Write Kirchhoff’s Current Equations for the nodes. Simplify the equations. Write the equations in matrix form & find the values of nodal voltages using determinants method. Voltage at the node is the voltage difference between node 1 & ground (Zero potential)

**XVI Results**

1. Observed value of voltage at node 1= .....
2. Calculated value of voltage at node 1 = .....
3. Observed value of voltage at node 2 = .....
4. Calculated value of voltage at node 2 = .....

**XVII Interpretation of results:**

.....  
 .....  
 .....

**XVIII Conclusions and Recommendation:**

.....  
 .....  
 .....

**XIX Practical related Questions**

1. Can we perform the experiment with ac supply also? Justify.
2. Can we use the nodal voltage to find branch currents? If yes explain.

**[Space for Answers]**

.....  
 .....





**XX References / Suggestions for further Reading->**

Author: V.K. MEHTA, ROHIT MEHTA, Title: Basic Electrical Engineering, Publisher: S. Chand & Co.

**XXI Assessment Scheme**

| <b>Performance indicators</b>     |   | <b>Weightage</b> |
|-----------------------------------|---|------------------|
| <b>Process related (10 Marks)</b> |   | <b>40%</b>       |
| 1                                 | Selection of equipment, components, instruments | 10%              |
| 2                                 | Proper connection of circuit                    | 10%              |
| 3                                 | Neatness in the arrangement of circuit          | 10%              |
| 4                                 | Procedural steps followed                       | 10%              |
| <b>Product related (15 Marks)</b> |   | <b>60%</b>       |
| 5                                 | Accuracy in calculations                        | 20%              |
| 6                                 | Representation of phasor diagram                | 20%              |
| 7                                 | Interpretation of results                       | 10%              |
| 8                                 | Conclusion                                      | 05%              |
| 9                                 | Submitting the journal in time                  | 05%              |
| <b>Total (25 Marks)</b>           |   | <b>100 %</b>     |

***Names of Student Team Members***

1. ....
2. ....
3. ....
4. ....

| <b>Marks Obtained</b>      |                            |                   | <b>Dated signature of Teacher</b> |
|----------------------------|----------------------------|-------------------|-----------------------------------|
| <b>Process Related(15)</b> | <b>Product Related(10)</b> | <b>Total (25)</b> |                                   |
|                            |                            |                   |                                   |

## Practical No.11: Superposition Theorem

### I **Practical Significance:**

The Electrical & Electronic circuit for different systems involves a number of branches. Many a times as per the requirement, measurement of current, voltage & power across a branch is required. These parameters of the circuit can be calculated using Superposition theorem. This experiment will help you to verify the theoretically obtained current through a branch using super position theorem.

### II **Relevant Program Outcomes (POs)**

- **Discipline knowledge:** Apply knowledge of basic mathematics, sciences and basic engineering to solve the broad-based Digital Electronics/Industrial Electronics/Electronics & Telecommunication related problems.
- **Experiments and practice:** Plan to perform experiments and practices to use the results to solve broad-based Digital Electronics/Industrial Electronics/Electronics & Telecommunication problems.
- **Engineering tools:** Apply relevant Digital Electronics/Industrial Electronics/Electronics & Telecommunication technologies and tools with an understanding of the limitations.

### III **Competency and Practical Skills**

The aim of this course is to help the student to attain the following industry identified Competency through various teaching learning experiences:

#### **Diagnose the electrical and electronic circuit problem.**

This practical is expected to develop the following skills in students.

1. Use Digital multimeter, ammeter to measure the voltage, current and power.
2. Calculate & compare voltage values

### IV **Relevant Course Outcomes:**

Use the principles of circuit analysis to check the functionality.

### V **Practical Outcome:**

Determine the current through given branch & voltage across the given element of circuit by applying Superposition theorem

### VI **Relevant Affective domain related Outcome(s)**

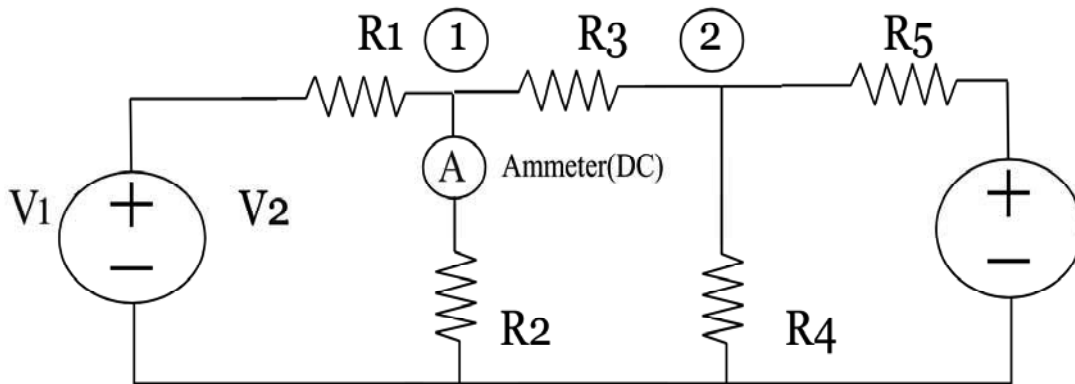
- a. Practice good housekeeping
- b. Maintain tools and equipment
- c. Follow standard test procedures.

**VII Minimum Theoretical Background**

Definition of Superposition theorem- For a linear system the response (voltage or current) in any branch of a bilateral linear circuit having more than one independent sources equals the algebraic sum of the responses caused by each independent sources acting alone, where all the other independent sources are replaced by their internal impedances.

**VIII Practical Circuit Diagram :**

**a) Sample**



**Figure 11.1**  
(Ammeter should be connected in each branch )

**b) Actual Circuit / Experimental set up used in laboratory**

**IX Resources required**

| S. No. | Instrument /Components | Specification | Quantity | Remarks |
|--------|------------------------|---------------|----------|---------|
| 1.     | Resistances            | 0- 100 Ohm    | 3        |         |
| 2.     | Bread board            |               | 1        |         |
| 3.     | Ammeter                | 1 Amp         | 1        |         |
| 4.     | Voltage source         | 0 -30 V 1 Amp | 2        |         |

**X Precautions**

1. Keep the resistances at maximum position
2. Check the connection before connecting circuit to supply
3. Apply voltage as per rating of the resistors, ammeter

**XI Procedure:**

1. Connect the circuit as shown in figure
2. Initially keep both the switches open
3. Switch on one of the supplies,
4. Read current values  $I_1$
5. Switch off the supply
6. Switch on the other supply
7. Read current value for  $I_2$
8. Switch off the supply
9. Switch on both supplies measure current  $I$
10. Read current value for  $I$
11. Switch off the supply

**XII Resources used (with major specifications)**

| S. No. | Instrument /Components | Specification | Quantity |
|--------|------------------------|---------------|----------|
| 1.     |                        |               |          |
| 2.     |                        |               |          |
| 3.     |                        |               |          |
| 4.     |                        |               |          |
| 5.     |                        |               |          |

**XIII Actual procedure followed**

.....

.....

.....

.....

.....

.....  
.....  
.....

**XIV Precautions followed**

.....  
.....  
.....  
.....

**XV Observations and Calculations:-**

**Table 11.1: Observed values of current through BD**

| Sr.No. | I <sub>1</sub> (A) | I <sub>2</sub> (A) | I <sub>1</sub> (A)+ I <sub>2</sub> (A) | I(A) |
|--------|--------------------|--------------------|--|------|
| 1      |                    |                    |  |      |
| 2      |                    |                    |  |      |

**Calculations:** Determine the current through the branch BD using Superposition theorem

**XVI Results**

1. Observed value of current through branch BD  $I_1(A) + I_2(A) =$  .....
2. Observed value of current through branch BD  $I(A) =$  .....

**XVII Interpretation of results:**

.....  
.....  
.....

**XVIII Conclusions and Recommendation:**

.....  
.....  
.....

**XIX Practical related Questions**

1. Can we perform the experiment with ac supply also? Justify.
2. Can we use the nodal voltage to find branch currents? If yes explain.
3. State why to use switches

**[Space for Answers]**

.....  
.....

.....

.....

.....

.....

.....

.....

.....

**XX References / Suggestions for further Reading**

Author: V.K. MEHTA, ROHIT MEHTA, Title: Basic Electrical Engineering, Publisher: S. Chand & Co.

**XXI Assessment Scheme**

| <b>Performance indicators</b>     |   | <b>Weightage</b> |
|-----------------------------------|---|------------------|
| <b>Process related (10 Marks)</b> |   | <b>40%</b>       |
| 1                                 | Selection of equipment, components, instruments | 10%              |
| 2                                 | Proper connection of circuit                    | 10%              |
| 3                                 | Neatness in the arrangement of circuit          | 10%              |
| 4                                 | Procedural steps followed                       | 10%              |
| <b>Product related (15 Marks)</b> |   | <b>60%</b>       |
| 5                                 | Accuracy in calculations                        | 20%              |
| 6                                 | Representation of phasor diagram                | 20%              |
| 7                                 | Interpretation of results                       | 10%              |
| 8                                 | Conclusion                                      | 05%              |
| 9                                 | Submitting the journal in time                  | 05%              |
| <b>Total (25 Marks)</b>           |   | <b>100 %</b>     |

***Names of Student Team Members***

1. ....
2. ....
3. ....
4. ....

| <b>Marks Obtained</b>      |                            |                   | <b>Dated signature of Teacher</b> |
|----------------------------|----------------------------|-------------------|-----------------------------------|
| <b>Process Related(15)</b> | <b>Product Related(10)</b> | <b>Total (25)</b> |                                   |
|                            |                            |                   |                                   |

## Practical No.12: Thevenin's theorem & Norton's theorem

### I Practical Significance:

The Electrical & Electronic circuit for different systems involves a number of branches. Many a times as per the requirement, measurement of current, voltage & power across a branch is required. These parameters of the circuit can be calculated using Thevenin's theorem and Norton's theorem. This experiment will help you to verify the theoretically obtained current through a branch using Thevenin's theorem & Norton's theorem.

### II Relevant Program Outcomes (POs)

- **Discipline knowledge:** Apply knowledge of basic mathematics, sciences and basic engineering to solve the broad-based Digital Electronics/Industrial Electronics/Electronics & Telecommunication related problems.
- **Experiments and practice:** Plan to perform experiments and practices to use the results to solve broad-based Digital Electronics/Industrial Electronics/Electronics & Telecommunication problems.
- **Engineering tools:** Apply relevant Digital Electronics/Industrial Electronics/Electronics & Telecommunication technologies and tools with an understanding of the limitations.

### III Competency and Practical Skills

The aim of this course is to help the student to attain the following industry identified Competency through various teaching learning experiences:

#### Diagnose the electrical and electronic circuit problem.

This practical is expected to develop the following skills in students.

1. Use Digital multimeter, ammeter to measure the voltage, current, equivalent resistance
2. Calculate voltage values

### IV Relevant Course Outcomes:

Use network theorems to determine the various parameters in circuits.

### V Practical Outcome:

Determine equivalent circuit parameter in a given circuit by applying Thevenin's and Norton's theorem.

### VI Relevant Affective domain related Outcome(s)

- a. Maintain tools and equipment.
- b. Follow standard test procedures.



## VII Minimum Theoretical Background

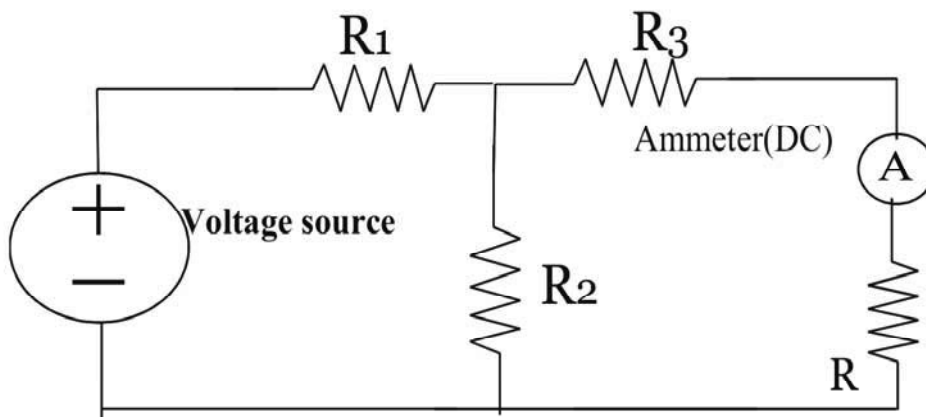
Statement of Thevenin's theorem: Any linear, bilateral network having terminals A & B can be replaced by a single source of e.m.f.  $V_{TH}$  in series with a single resistance.  $R_N$  is the voltage obtained across the terminals A and B with load, if any removed. The resistance  $R_{TH}$  is the resistance of the network measured between terminals A and B with load removed and sources of e.m.f. replaced by their internal resistances. Ideal voltage sources removed with short circuits and ideal current sources replaced with open circuit.

Statement of Norton's theorem:- Any linear bilateral network having two terminals A and B can be replaced by a current source of a current output  $I_N$  in parallel with a resistance  $R_N$ . The output current  $I_N$  of the current source is equal to the current that would flow through AB when A and B are short circuited. The resistance  $R_N$  is the resistance of the network measured between A and B with load removed & the sources of e.m.f. replaced by their internal resistances. Ideal voltage sources replaced with short circuits and ideal current sources are replaced with open circuit.

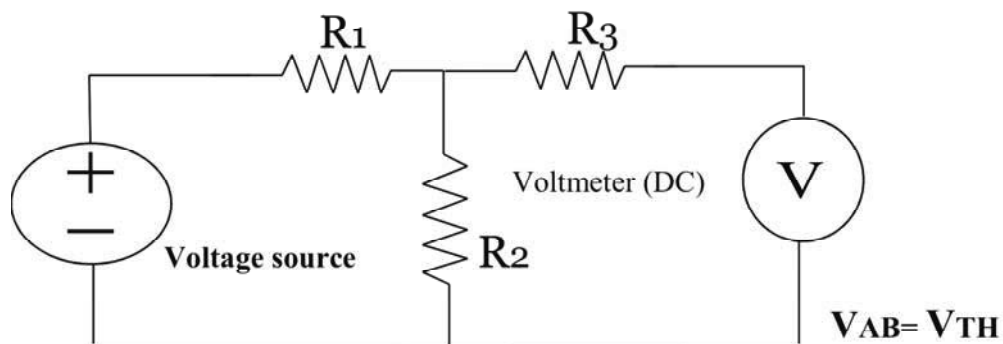
## VIII Practical Circuit Diagram :

### a) Sample

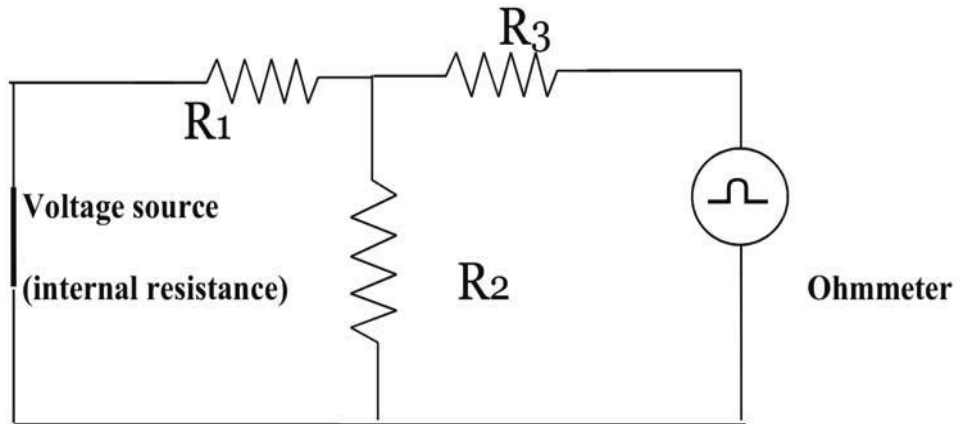
(A) To find actual current through R



(B) To measure Thevenin's voltage



(C) To measure resistance  $R_N$  or  $R_{TH}$



(D) To find Norton's Equivalent  $I_N$

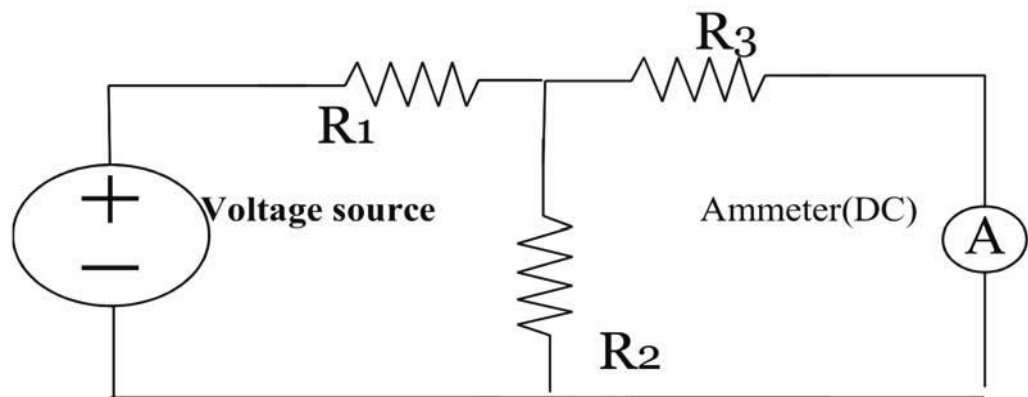


Figure 11.1:

b) Actual Circuit / Experimental set up used in laboratory

**IX Resources required**

| S. No. | Instrument /Components | Specification    | Quantity | Remarks |
|--------|------------------------|------------------|----------|---------|
| 1.     | Resistances            | 0 -100 Ohm       | 3        |         |
| 2.     | Bread board            |                  | 1        |         |
| 3.     | Ammeter                | 1 Amp            | 1        |         |
| 4.     | Voltage source         | 0 -30 V DC 1 Amp | 1        |         |

**X Precautions**

1. Keep the resistances at maximum position
2. Check the connection before connecting circuit to supply
3. Apply voltage as per rating of the resistors, ammeter

**XI Procedure:****A. To find Thevenin's equivalent**

1. Remove the resistance through which current is to be found out
2. Switch on the supply
3. Using multi meter measure voltage across the open terminals  $V_{TH}$  i.e. removed resistance terminals
4. Switch off the supply
5. Remove the source by internal resistance i.e. voltage source by short circuit.
6. Measure the resistance across open terminals,  $R_{TH}$

**B. To find Norton's equivalent**

1. Replace the resistance through which current is to be found out, with an ammeter.
2. Switch on the supply.
3. Note down the reading of the ammeter  $I_N$  i.e. across removed resistance terminals.
4. Switch off the supply.

**XII Resources used (with major specifications)**

| S. No. | Instrument /Components | Specification | Quantity |
|--------|------------------------|---------------|----------|
| 1.     | Resistances            |               |          |
| 2.     | Bread board            |               |          |
| 3.     | Ammeter                |               |          |
| 4.     | Voltage source         |               |          |

**XIII Actual procedure followed**

.....

.....

.....

.....

.....

.....

.....

.....

**XIV Precautions followed**

.....

.....

.....

**XV Observations and Calculations:**

**Table 11.1: Observed and Calculated value of current through branch AB**

| Sr. No. | Supply Voltage | V <sub>TH</sub> (Observed) | V <sub>TH</sub> (Calculated) | R <sub>TH</sub> |
|---------|----------------|----------------------------|------------------------------|-----------------|
| 1       |                |                            |                              |                 |
| 2       |                |                            |                              |                 |

**Table2 : Observed & Calculated value of current through branch AB**

| Sr. No. | Supply Voltage | I <sub>N</sub> (Observed) | I <sub>N</sub> (Calculated) | R <sub>N</sub> |
|---------|----------------|---------------------------|-----------------------------|----------------|
| 1       |                |                           |                             |                |
| 2       |                |                           |                             |                |

**Calculations:** Determine the current through the branch AB using Thevenin’s theorem and Norton’s theorem

**XVI Results**

1. Thevenin’s equivalent circuit parameter V<sub>TH</sub>& R<sub>TH</sub>.....
2. Norton’s equivalent circuit parameters=I<sub>N</sub>& R<sub>N</sub>.....



.....

.....

.....

.....

.....

.....

**XX References / Suggestions for further Reading**

Author: V.K. MEHTA, ROHIT MEHTA, Title: Basic Electrical Engineering, Publisher: S. Chand & Co.

**XXI Assessment Scheme**

| Performance indicators            |   | Weightage    |
|-----------------------------------|---|--------------|
| <b>Process related (10 Marks)</b> |   | <b>40%</b>   |
| 1                                 | Selection of equipment, components, instruments | 10%          |
| 2                                 | Proper connection of circuit                    | 10%          |
| 3                                 | Neatness in the arrangement of circuit          | 10%          |
| 4                                 | Procedural steps followed                       | 10%          |
| <b>Product related (15 Marks)</b> |   | <b>60%</b>   |
| 5                                 | Accuracy in calculations                        | 20%          |
| 6                                 | Representation of phasor diagram                | 20%          |
| 7                                 | Interpretation of results                       | 10%          |
| 8                                 | Conclusion                                      | 05%          |
| 9                                 | Submitting the journal in time                  | 05%          |
| <b>Total (25 Marks)</b>           |   | <b>100 %</b> |

***Names of Student Team Members***

1. ....
2. ....
3. ....
4. ....

| Marks Obtained      |                     |            | Dated signature of Teacher |
|---------------------|---------------------|------------|----------------------------|
| Process Related(15) | Product Related(10) | Total (25) |                            |
|                     |                     |            |                            |

## Practical No.: 13 Maximum power transfer theorem

### I Practical Significance:

The Electrical & Electronic circuit for different systems involves a number of branches. Many a times as per the requirement, measurement of current, voltage & power across a branch is required. Maximum power transfer theorem is useful to make the circuit efficient, so the power loss will be minimum compared to power transferred.

### II Relevant Program Outcomes (POs)

- **Discipline knowledge:** Apply knowledge of basic mathematics, sciences and basic engineering to solve the broad-based Digital Electronics/Industrial Electronics/Electronics & Telecommunication related problems.
- **Experiments and practice:** Plan to perform experiments and practices to use the results to solve broad-based Digital Electronics/Industrial Electronics/Electronics & Telecommunication problems.
- **Engineering tools:** Apply relevant Digital Electronics/Industrial Electronics/Electronics & Telecommunication technologies and tools with an understanding of the limitations.

### III Competency and Practical Skills

The aim of this course is to help the student to attain the following industry identified Competency through various teaching learning experiences:

#### Diagnose the electrical and electronic circuit problem.

This practical is expected to develop the following skills in students.

1. To change load resistance precisely
2. Observe the power values with respect to change in load resistance

### IV Relevant Course Outcomes:

Use network theorems to determine the various parameters in circuits.

### V Practical Outcome:

Determine the load resistance for maximum power transfer for a given circuit by applying maximum power transfer theorem

### VI Relevant Affective domain related Outcome(s)

- a. Control the current
- b. Maintain tools and equipment
- c. Note the reading carefully

**VII Minimum Theoretical Background**

From Thevenin's theorem, Thevenin's equivalent circuit or from Norton's theorem Norton's equivalent circuit is obtained. The condition for maximum power to transfer is Load resistance = Internal resistance i.e. Load resistance =  $R_{TH}$  or  $R_N$

**Statement of Maximum Power transfer theorem:-** In any linear bilateral circuit Maximum Power transfer will take place only when load Resistance is equal to source resistance ( $R_L = R_{TH}$  or  $R_N$ )

**VIII Practical Circuit Diagram :**

a) Sample

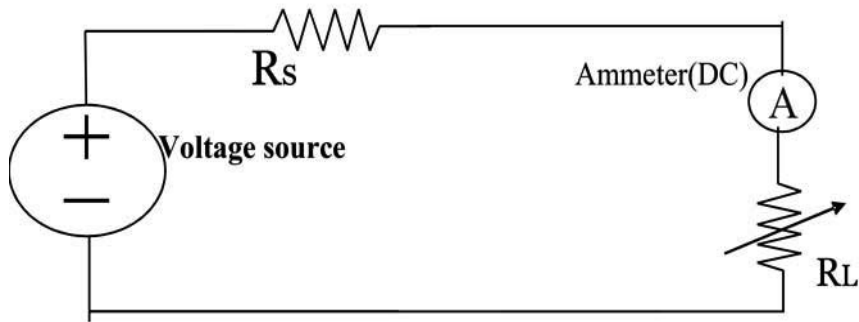


Figure 13.1

b) Actual Circuit / Experimental set up used in laboratory



**IX Resources required**

| Sr. No | Instrument /Components | Specification    | Quantity | Remarks |
|--------|------------------------|------------------|----------|---------|
| 1      | Resistances            |                  | 3        |         |
| 2      | Bread board            |                  | 1        |         |
| 3      | Ammeter                | 1 Amp            | 1        |         |
| 4      | Voltage source         | 0 -30 V DC 1 Amp | 2        |         |

**X Precautions**

1. Keep the resistances at maximum position
2. Check the connection before connecting circuit to supply
3. Apply voltage as per rating of the resistors, ammeter

**XI Procedure:**

1. Connect the circuit as shown in figure
2. Switch on the supply
3. Read the power through load, by varying the load resistance in steps
4. Reduce the supply voltage
5. Switch off the supply
6. Measure the load resistance according to steps

**XII Resources used (with major specifications)**

| S. No. | Instrument /Components | Specification | Quantity |
|--------|------------------------|---------------|----------|
| 1.     |                        |               |          |
| 2.     |                        |               |          |
| 3.     |                        |               |          |
| 4.     |                        |               |          |
| 5.     |                        |               |          |

**XIII Actual procedure followed**

.....

.....

.....

.....

.....

.....

.....

.....

**XIV Precautions followed**

.....  
 .....  
 .....

**XV Observations and Calculations:**

**Table 1:**

| Sr. No. | Supply Voltage (V) | Power delivered to load (watts) | Internal resistance( $\Omega$ ) | Load Resistance ( $\Omega$ ) | Calculated Power $I^2 R_L$ |
|---------|--------------------|---------------------------------|---------------------------------|------------------------------|----------------------------|
| 1       |                    |                                 |                                 |                              |                            |
| 2       |                    |                                 |                                 |                              |                            |
| 3       |                    |                                 |                                 |                              |                            |
| 4       |                    |                                 |                                 |                              |                            |
| 5       |                    |                                 |                                 |                              |                            |
| 6       |                    |                                 |                                 |                              |                            |

**Calculations:**

**XVI Results**

1. Maximum power transferred=                      watts
2. Value of load resistance corresponding to maximum power=  $\Omega$

**XVII Interpretation of results:**

.....  
 .....  
 .....

**XVIII Conclusions and Recommendation:**

.....  
 .....  
 .....



**XX References / Suggestions for further Reading-**

Author: V.K. MEHTA, ROHIT MEHTA, Title: Basic Electrical Engineering, Publisher: S. Chand & Co.

**XXI Assessment Scheme**

| <b>Performance indicators</b>     |   | <b>Weightage</b> |
|-----------------------------------|---|------------------|
| <b>Process related (10 Marks)</b> |   | <b>40%</b>       |
| 1                                 | Selection of equipment, components, instruments | 10%              |
| 2                                 | Proper connection of circuit                    | 10%              |
| 3                                 | Neatness in the arrangement of circuit          | 10%              |
| 4                                 | Procedural steps followed                       | 10%              |
| <b>Product related (15 Marks)</b> |   | <b>60%</b>       |
| 5                                 | Accuracy in calculations                        | 20%              |
| 6                                 | Representation of phasor diagram                | 20%              |
| 7                                 | Interpretation of results                       | 10%              |
| 8                                 | Conclusion                                      | 05%              |
| 9                                 | Submitting the journal in time                  | 05%              |
| <b>Total (25 Marks)</b>           |   | <b>100 %</b>     |

*Names of Student Team Members*

1. ....
2. ....
3. ....
4. ....

| <b>Marks Obtained</b>      |                            |                   | <b>Dated signature of Teacher</b> |
|----------------------------|----------------------------|-------------------|-----------------------------------|
| <b>Process Related(15)</b> | <b>Product Related(10)</b> | <b>Total (25)</b> |                                   |
|                            |                            |                   |                                   |

## Practical No.14: Reciprocity theorem

### I **Practical Significance:**

The Electrical & Electronic circuit for different systems involves a number of branches. Many a times as per the requirement, measurement of current, voltage & power across a branch is required. Reciprocity theorem provides convenience of converting voltage response into current response & vice versa.

### II **Relevant Program Outcomes (POs)**

- **Discipline knowledge:** Apply knowledge of basic mathematics, sciences and basic engineering to solve the broad-based Digital Electronics/Industrial Electronics/Electronics & Telecommunication related problems.
- **Experiments and practice:** Plan to perform experiments and practices to use the results to solve broad-based Digital Electronics/Industrial Electronics/Electronics & Telecommunication problems.
- **Engineering tools:** Apply relevant Digital Electronics/Industrial Electronics/Electronics & Telecommunication technologies and tools with an understanding of the limitations.

### III **Competency and Practical Skills**

The aim of this course is to help the student to attain the following industry identified Competency through various teaching learning experiences:

#### **Diagnose the electrical and electronic circuit problem.**

This practical is expected to develop the following skills in students.

1. Use ammeter to measure current
2. Compare current values with changed position of ammeter & source

### IV **Relevant Course Outcomes:**

Use network theorems to determine the various parameters in circuits.

### V **Practical Outcome:**

Test the response of the given circuit by applying reciprocity theorem.

### VI **Relevant Affective domain related Outcome(s)**

- a. Carefully interchange the place of devices.

**VII Minimum Theoretical Background**

In any linear, bilateral network, if an e.m.f.  $E$  acting in a branch  $X$  causes a current  $I$  in branch  $Y$ , then the same e.m.f.  $E$  located in branch  $Y$  will cause a current  $I$  in branch  $X$ . However, currents in the other parts of the network will not remain the same.

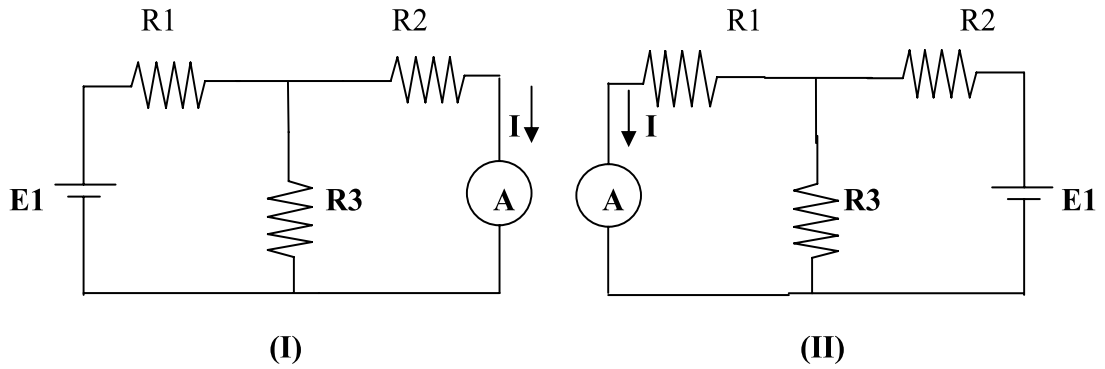
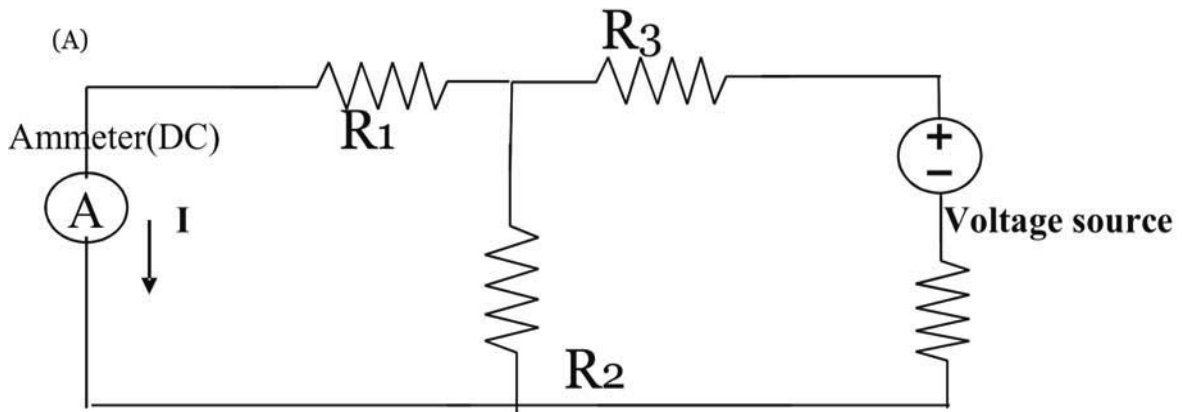


Figure 14.1

**VIII Practical Circuit Diagram :-**

a) Sample



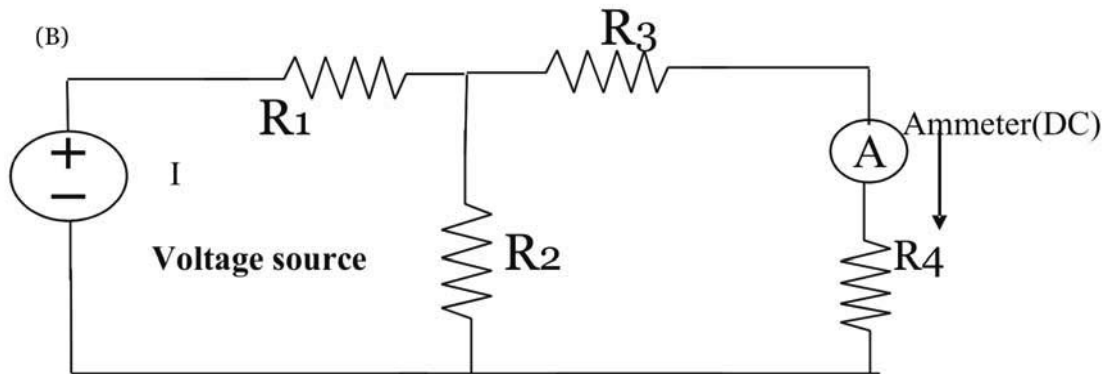


Figure 14. 2:

**b) Actual Circuit / Experimental set up used in laboratory**

**IX Resources required**

| S. No. | Instrument /Components | Specification | Quantity | Remarks |
|--------|------------------------|---------------|----------|---------|
| 1      | Resistances            |               | 2        |         |
| 2      | Bread board            |               | 1        |         |
| 3      | Ammeter                | 50mA          | 1        |         |
| 4      | Voltage source         | 5V DC         | 2        |         |

**X Precautions**

1. Keep the resistances at maximum position
2. Check the connection before connecting circuit to supply
3. Apply voltage as per rating of the resistors, ammeter.

**XI Procedure:**

1. Connect the circuit as shown in figure 1.(I)
2. Switch on the supply
3. Read current of ammeter
4. Switch off the supply
5. Connect the circuit as shown in figure 1.(II)
6. Switch on the supply again
7. Read the current of ammeter
8. Switch off the supply

**XII Resources used (with major specifications)**

| S. No. | Instrument /Components | Specification | Quantity |
|--------|------------------------|---------------|----------|
| 1.     |                        |               |          |
| 2.     |                        |               |          |
| 3.     |                        |               |          |
| 4.     |                        |               |          |

**XIII Actual procedure followed**

.....  
 .....  
 .....  
 .....  
 .....  
 .....  
 .....  
 .....

**XIV Precautions followed**

.....  
 .....  
 .....

**XV Observations and Calculations:**

**Table 1: Observed value of current**

| Sr. No. | Supply Voltage (V) | I(A) Fig. (I) | I(A) Fig. (II) |
|---------|--------------------|---------------|----------------|
| 1       |                    |               |                |
| 2       |                    |               |                |





.....

.....

.....

.....

.....

**XX References / Suggestions for further Reading**

Author: V.K. MEHTA, ROHIT MEHTA, Title: Basic Electrical Engineering, Publisher: S. Chand & Co.

**XXI Assessment Scheme**

| Performance indicators            |   | Weightage    |
|-----------------------------------|---|--------------|
| <b>Process related (10 Marks)</b> |   | <b>40%</b>   |
| 1                                 | Selection of equipment, components, instruments | 10%          |
| 2                                 | Proper connection of circuit                    | 10%          |
| 3                                 | Neatness in the arrangement of circuit          | 10%          |
| 4                                 | Procedural steps followed                       | 10%          |
| <b>Product related (15 Marks)</b> |   | <b>60%</b>   |
| 5                                 | Accuracy in calculations                        | 20%          |
| 6                                 | Representation of phasor diagram                | 20%          |
| 7                                 | Interpretation of results                       | 10%          |
| 8                                 | Conclusion                                      | 05%          |
| 9                                 | Submitting the journal in time                  | 05%          |
| <b>Total (25 Marks)</b>           |   | <b>100 %</b> |

***Names of Student Team Members***

1. ....
2. ....
3. ....
4. ....

| Marks Obtained      |                     |            | Dated signature of Teacher |
|---------------------|---------------------|------------|----------------------------|
| Process Related(15) | Product Related(10) | Total (25) |                            |
|                     |                     |            |                            |

## Practical No.15: Z Parameters

### I **Practical Significance:**

A two port network is an electric circuit with two input ports & two output ports. The examples of two port network are bridge circuits, filters, transformers, etc. At the input terminals the external signals are fed & are transmitted through the network to the output terminals. It is useful in determining the performance of the circuit network & design filters. Z parameters represent the circuit performance.

### II **Relevant Program Outcomes (POs)**

- **Discipline knowledge:** Apply knowledge of basic mathematics, sciences and basic engineering to solve the broad-based Digital Electronics/Industrial Electronics/Electronics & Telecommunication related problems.
- **Experiments and practice:** Plan to perform experiments and practices to use the results to solve broad-based Digital Electronics/Industrial Electronics/Electronics & Telecommunication problems.
- **Engineering tools:** Apply relevant Digital Electronics/Industrial Electronics/Electronics & Telecommunication technologies and tools with an understanding of the limitations.

### III **Competency and Practical Skills**

The aim of this course is to help the student to attain the following industry identified Competency through various teaching learning experiences:

#### **Diagnose the electrical and electronic circuit problem.**

This practical is expected to develop the following skills in students.

1. Interpret the circuit parameters Z in terms of voltage & current
2. Connect the resistors as network & create port

### IV **Relevant Course Outcomes:**

Use two port networks to determine the circuit parameters

### V **Practical Outcome:**

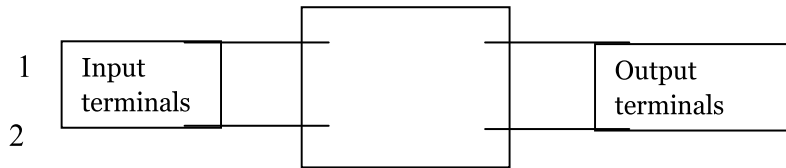
Determine open circuit (Z) parameters for the given network.

### VI **Relevant Affective domain related Outcome(s)**

To designate terminals of a port

**VII Minimum Theoretical Background**

$V_1$  = Input voltage,  $V_2$  = Output voltage,  $I_1$  = Input current,  $I_2$  = Output current



**Figure 15.1**

Z Parameters

$$V_1 = Z_{11}I_1 + Z_{12} I_2$$

$$V_2 = Z_{21}I_1 + Z_{22} I_2$$

Let  $I_1$  or  $I_2$  be zero. For this condition,

$$Z_{11} = V_1/I_1 \text{ at } I_2 = 0;$$

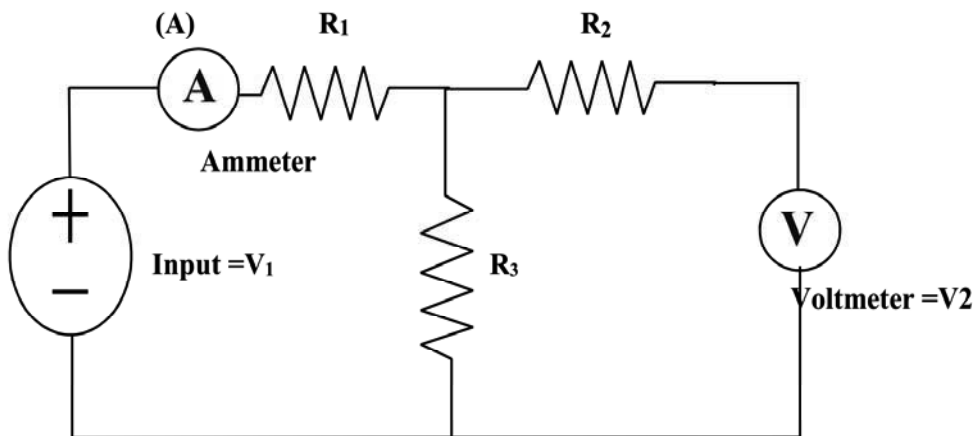
$$Z_{21} = V_2/I_1 \text{ at } I_2 = 0;$$

$$Z_{12} = V_1/I_2 \text{ at } I_1 = 0;$$

$$Z_{22} = V_2/I_2 \text{ at } I_1 = 0$$

**VIII Practical Circuit Diagram :**

a) Sample



**Figure15. 2**

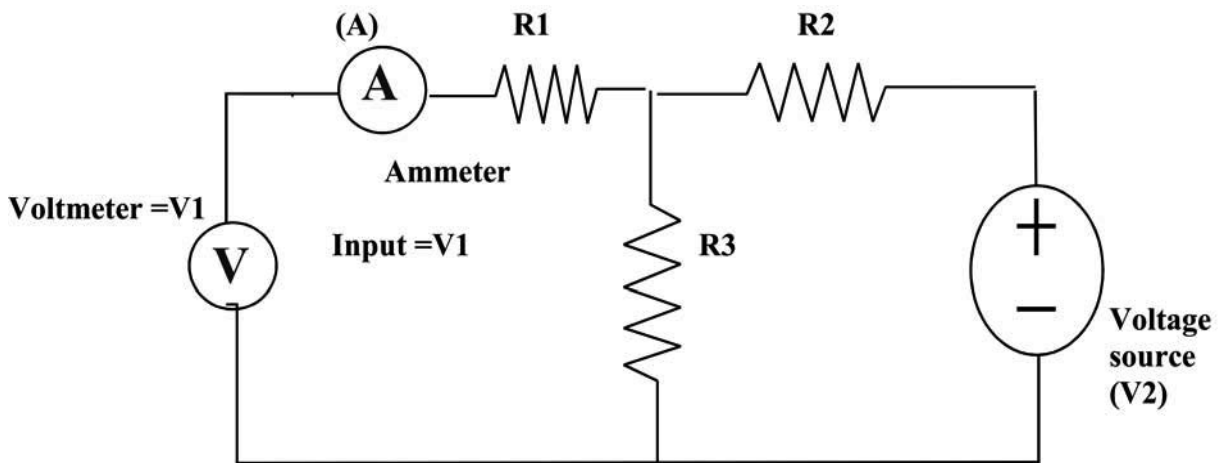


Figure 15.3

**b) Actual Circuit / Experimental set up used in laboratory**

**IX Resources required**

Following Table Format Should be Single Line

| S. No. | Instrument /Components | Specification | Quantity | Remarks |
|--------|------------------------|---------------|----------|---------|
| 1      | Resistances            |               | 3        |         |
| 2      | Bread board            |               | 1        |         |
| 3      | Ammeter                | 1 Amp         | 1        |         |
| 4      | Voltage source         | 0 -30 V 1 Amp | 2        |         |

**X Precautions**

1. Keep the resistances at maximum position.
2. Check the connection before connecting circuit to supply.
3. Apply voltage as per rating of the resistors, ammeter.

**XI Procedure:**

1. Connect the circuit as shown in figure 1
2. Switch on the supply
3. Measure the voltage across terminal 2
4. Read ammeter reading for I1
5. Switch off the supply
6. Connect the circuit as shown in figure 2
7. Switch on the supply
8. Measure the voltage across terminal 1
9. Read ammeter reading for I2

**XII Resources used (with major specifications)**

| S. No. | Instrument /Components | Specification | Quantity |
|--------|------------------------|---------------|----------|
| 1.     |                        |               |          |
| 2.     |                        |               |          |
| 3.     |                        |               |          |
| 4.     |                        |               |          |
| 5.     |                        |               |          |
| 6.     |                        |               |          |

**XIII Actual procedure followed**

.....  
 .....  
 .....

**XIV Precautions followed**

.....  
 .....  
 .....

**XV Observations and Calculations:**

**Table15. 1: Observed value of Z parameters**

| Sr. No. | V1(V) | V2(V) | I1(A) | I2(A) | Parameter       | Observed Value( $\Omega$ ) |
|---------|-------|-------|-------|-------|-----------------|----------------------------|
| 1       |       |       |       | 0     | Z <sub>11</sub> |                            |
| 2       |       |       | 0     |       | Z <sub>12</sub> |                            |
| 3       |       |       |       | 0     | Z <sub>21</sub> |                            |
| 4       |       |       | 0     |       | Z <sub>22</sub> |                            |

**Calculations:**

$$Z_{11} = V_1 / I_1 \text{ at } I_2 = 0;$$

$$Z_{21} = V_2 / I_1 \text{ at } I_2 = 0;$$

$$Z_{12} = V_1 / I_2 \text{ at } I_1 = 0;$$

$$Z_{22} = V_2 / I_2 \text{ at } I_1 = 0$$

**XVI Results**

**XVII Interpretation of results:**

.....  
.....  
.....

**XVIII Conclusions and Recommendation:**

.....  
.....  
.....

**XIX Practical related Questions**

1. Can we find the values without supply?

**[Space for Answers]**

.....  
.....  
.....  
.....  
.....  
.....  
.....  
.....  
.....

.....

.....

.....

.....

.....

.....

.....

**XX References / Suggestions for further Reading**

Author: V.K. MEHTA, ROHIT MEHTA, Title: Basic Electrical Engineering, Publisher: S. Chand & Co.

**XXI Assessment Scheme**

| Performance indicators            |   | Weightage    |
|-----------------------------------|---|--------------|
| <b>Process related (10 Marks)</b> |   | <b>40%</b>   |
| 1                                 | Selection of equipment, components, instruments | 10%          |
| 2                                 | Proper connection of circuit                    | 10%          |
| 3                                 | Neatness in the arrangement of circuit          | 10%          |
| 4                                 | Procedural steps followed                       | 10%          |
| <b>Product related (15 Marks)</b> |   | <b>60%</b>   |
| 5                                 | Accuracy in calculations                        | 20%          |
| 6                                 | Representation of phasor diagram                | 20%          |
| 7                                 | Interpretation of results                       | 10%          |
| 8                                 | Conclusion                                      | 05%          |
| 9                                 | Submitting the journal in time                  | 05%          |
| <b>Total (25 Marks)</b>           |   | <b>100 %</b> |

***Names of Student Team Members***

1. ....
2. ....
3. ....
4. ....

| Marks Obtained      |                     |            | Dated signature of Teacher |
|---------------------|---------------------|------------|----------------------------|
| Process Related(15) | Product Related(10) | Total (25) |                            |
|                     |                     |            |                            |



## Practical No.16: Y Parameters

### I **Practical Significance:**

A two port network is an electric circuit with two input ports & two output ports. The examples of two port network are bridge circuits, filters, transformers, etc. At the input terminals the external signals are fed & are transmitted through the network to the output terminals. It is useful in determining the performance of the circuit network & design filters. Y parameters represents the circuit.

### II **Relevant Program Outcomes (POs)**

- **Discipline knowledge:** Apply knowledge of basic mathematics, sciences and basic engineering to solve the broad-based Digital Electronics/Industrial Electronics/Electronics & Telecommunication related problems.
- **Experiments and practice:** Plan to perform experiments and practices to use the results to solve broad-based Digital Electronics/Industrial Electronics/Electronics & Telecommunication problems.
- **Engineering tools:** Apply relevant Digital Electronics/Industrial Electronics/Electronics & Telecommunication technologies and tools with an understanding of the limitations.

### III **Competency and Practical Skills**

The aim of this course is to help the student to attain the following industry identified Competency through various teaching learning experiences:

#### **Diagnose the electrical and electronic circuit problem.**

This practical is expected to develop the following skills in students.

1. Interpret the circuit parameters Y in terms of voltage & current
2. Connect the resistors as network & create port

### IV **Relevant Course Outcomes:**

Use two port networks to determine the circuit parameters.

### V **Practical Outcome:**

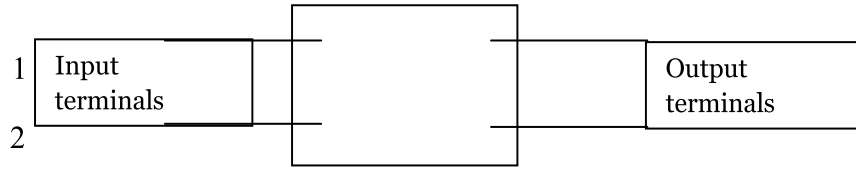
Determine short circuit (Y) parameters for the given network.

### VI **Relevant Affective domain related Outcome(s)**

- a. To designate terminals of a port

**VII Minimum Theoretical Background**

$V_1$  = Input voltage,  $V_2$  = Output voltage,  $I_1$  = Input current,  $I_2$  = Output current



**Figure 16.1**

Y Parameters

$$I_1 = Y_{11}V_1 + Y_{12}V_2$$

$$I_2 = Y_{21}V_1 + Y_{22}V_2$$

Let  $V_1$  or  $V_2$  be zero. For this condition,

$$Y_{11} = I_1/V_1 \text{ at } V_2 = 0;$$

$$Y_{21} = I_2/V_1 \text{ at } V_2 = 0;$$

$$Y_{12} = I_1/V_2 \text{ at } V_1 = 0;$$

$$Y_{22} = I_2/V_2 \text{ at } V_1 = 0$$

**VIII Practical Circuit Diagram :**

a) Sample

(A)

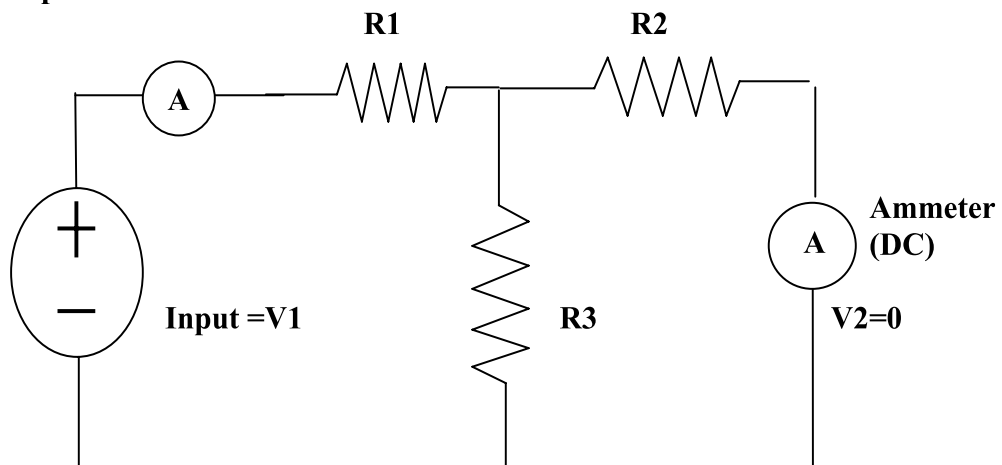


Figure 16.2:

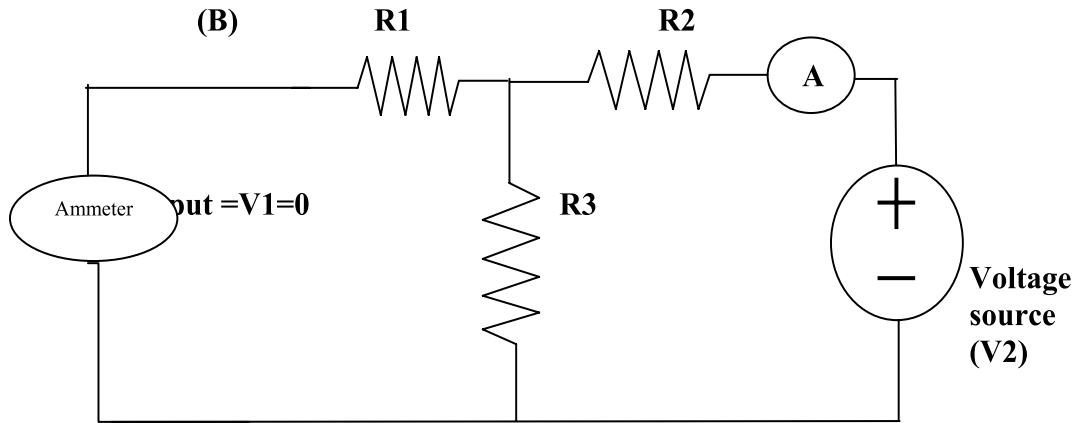


Figure 16.3

b) Actual Circuit / Experimental set up used in laboratory

**IX Resources required**

| S. No. | Instrument /Components | Specification | Quantity | Remarks |
|--------|------------------------|---------------|----------|---------|
| 1.     | Resistances            |               |          |         |
| 2.     | Breadboard             |               |          |         |
| 3.     | Power supply           | 0 -30 V 1 Amp |          |         |
| 4.     | Connecting leads       |               |          |         |
| 5.     | Voltmeter              | 0 -50 V       |          |         |
| 6.     | Ammeter                | 1 Amp         |          |         |

**X Precautions**

1. Keep the resistances at maximum position
2. Check the connection before connecting circuit to supply
3. Apply voltage as per rating of the resistors, ammeter

**XI Procedure:**

1. Connect the circuit as shown in figure 1
2. First short the output terminals & connect the 5V supply to Input terminals
3. Read ammeter reading for I1
4. Read ammeter reading for I2
5. Switch off the supply
6. Connect the circuit as shown in figure 2
7. Short the input terminals & connect the 5V supply Output terminals
8. Read ammeter reading for I1
9. Read ammeter reading for I2
10. Switch off the supply

**XII Resources used (with major specifications)**

| S. No. | Instrument /Components | Specification | Quantity |
|--------|------------------------|---------------|----------|
| 1.     |                        |               |          |
| 2.     |                        |               |          |
| 3.     |                        |               |          |
| 4.     |                        |               |          |
| 5.     |                        |               |          |
| 6.     |                        |               |          |

**XIII Actual procedure followed**

.....

.....

.....

.....

.....

.....

**XIV Precautions followed**

.....

.....

.....

.....

.....

.....

**XV Observations and Calculations:**

**Table 16.1: Observed value of Y parameters**

| Sr. No. | V1(V) | V2(V) | I1(A) | I2(A) | Parameter       | Observed Value ( $\Omega^{-1}$ ) |
|---------|-------|-------|-------|-------|-----------------|----------------------------------|
| 1       |       | 0     |       | -     | Y <sub>11</sub> |                                  |
| 2       |       | 0     |       | -     | Y <sub>12</sub> |                                  |
| 3       | 0     |       | -     |       | Y <sub>21</sub> |                                  |
| 4       | 0     |       | -     |       | Y <sub>22</sub> |                                  |

**Calculations:**

**XVI Results**

**XVII Interpretation of results:**

.....  
 .....  
 .....

**XVIII Conclusions and Recommendation:**

.....  
 .....  
 .....

**XIX Practical related Questions**

1. Can we use active sources in the network?
2. Can we find the values without supply?



**XX References / Suggestions for further Reading**

Author: V.K. MEHTA, ROHIT MEHTA, Title: Basic Electrical Engineering, Publisher: S. Chand & Co.

**XXI Assessment Scheme**

| <b>Performance indicators</b>     |   | <b>Weightage</b> |
|-----------------------------------|---|------------------|
| <b>Process related (10 Marks)</b> |   | <b>40%</b>       |
| 1                                 | Selection of equipment, components, instruments | 10%              |
| 2                                 | Proper connection of circuit                    | 10%              |
| 3                                 | Neatness in the arrangement of circuit          | 10%              |
| 4                                 | Procedural steps followed                       | 10%              |
| <b>Product related (15 Marks)</b> |   | <b>60%</b>       |
| 5                                 | Accuracy in calculations                        | 20%              |
| 6                                 | Representation of phasor diagram                | 20%              |
| 7                                 | Interpretation of results                       | 10%              |
| 8                                 | Conclusion                                      | 05%              |
| 9                                 | Submitting the journal in time                  | 05%              |
| <b>Total (25 Marks)</b>           |   | <b>100 %</b>     |

***Names of Student Team Members***

1. ....
2. ....
3. ....
4. ....

| <b>Marks Obtained</b>      |                            |                   | <b>Dated signature of Teacher</b> |
|----------------------------|----------------------------|-------------------|-----------------------------------|
| <b>Process Related(15)</b> | <b>Product Related(10)</b> | <b>Total (25)</b> |                                   |
|                            |                            |                   |                                   |

## Practical No.: 17 ABCD parameters

### I Practical Significance:

A two port network is an electric circuit with two input ports & two output ports. The examples of two port network are bridge circuits, filters, transformers, etc. At the input terminals the external signals are fed & are transmitted through the network to the output terminals. It is useful in determining the performance of the circuit network & design filters. It is also known as transmission line parameters. They express voltage & current at output port in terms of those at input port. They are useful in determining the transmission line performance

### II Relevant Program Outcomes (POs)

- **Discipline knowledge:** Apply knowledge of basic mathematics, sciences and basic engineering to solve the broad-based Digital Electronics/Industrial Electronics/Electronics & Telecommunication related problems.
- **Experiments and practice:** Plan to perform experiments and practices to use the results to solve broad-based Digital Electronics/Industrial Electronics/Electronics & Telecommunication problems.
- **Engineering tools:** Apply relevant Digital Electronics/Industrial Electronics/Electronics & Telecommunication technologies and tools with an understanding of the limitations.
- 4. **The engineer and society:** Assess societal, health, safety, legal and cultural issues and the consequent responsibilities relevant to practice in field of Industrial Electronics.

### III Competency and Practical Skills

The aim of this course is to help the student to attain the following industry identified Competency through various teaching learning experiences:

#### Diagnose the electrical and electronic circuit problem.

This practical is expected to develop the following skills in students.

1. Interpret the transmission line parameters A, B, C, D in terms of voltage & current
2. Connect the resistors as network & create port

### IV Relevant Course Outcomes:

Use two port networks to determine the circuit parameters

### V Practical Outcome:

Determine transmission line parameters A, B, C, and D for the given network.

### VI Relevant Affective domain related Outcome(s)

- a. To designate terminals of a port



## VII Minimum Theoretical Background

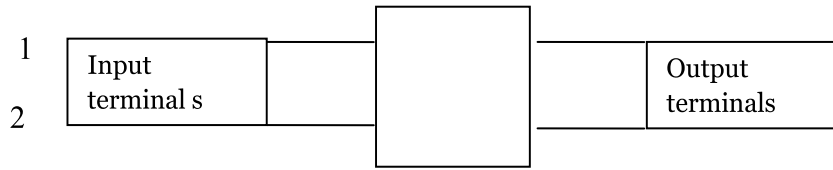


Figure 17.1:

A, B, C, D Parameters

$$V_1 = AV_2 - BI_2$$

$$I_1 = CV_2 - DI_2$$

$$A = V_1/V_2 \text{ at } I_2 = 0;$$

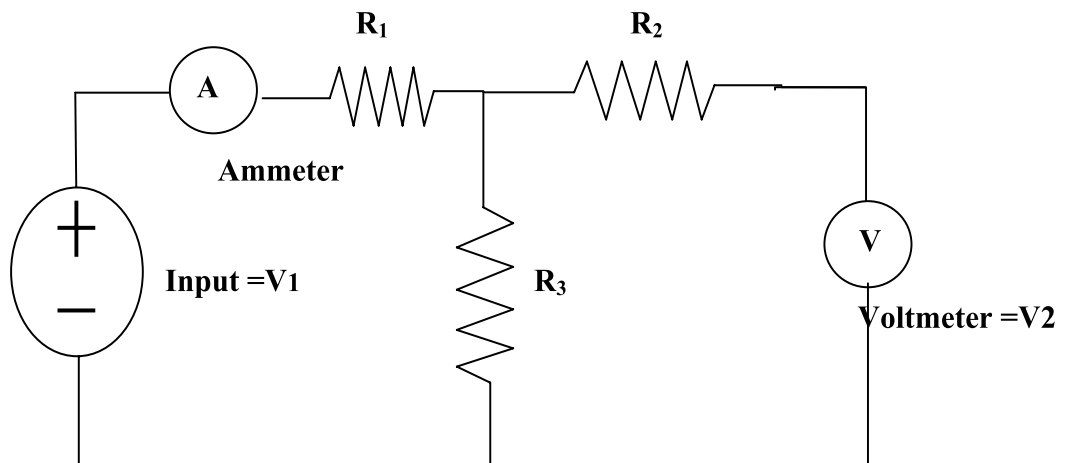
$$B = V_1/I_2 \text{ at } V_2 = 0;$$

$$C = I_1/V_2 \text{ at } I_2 = 0;$$

$$D = I_1/I_2 \text{ at } V_2 = 0$$

## VIII Practical Circuit Diagram :

a) Sample



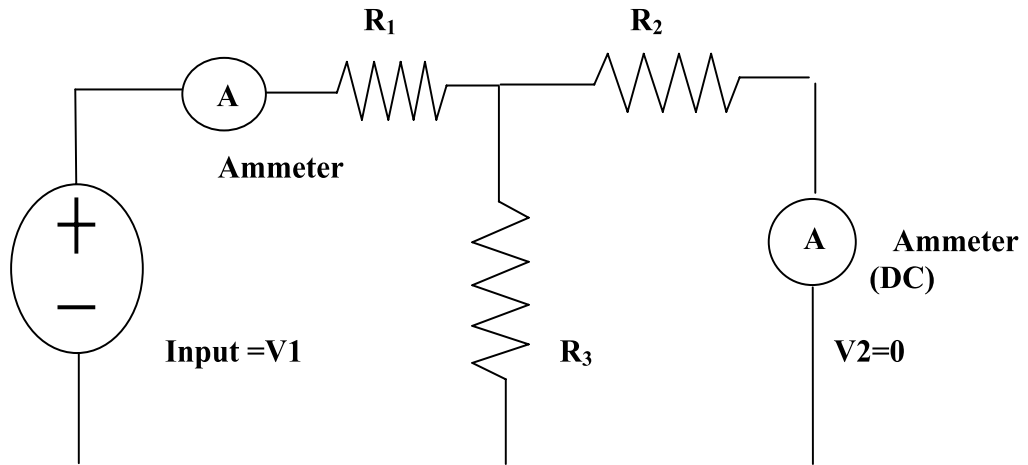


Figure 17.2:

b) Actual Circuit / Experimental set up used in laboratory

## IX Resources required

| S. No. | Instrument /Components | Specification    | Quantity | Remarks |
|--------|------------------------|------------------|----------|---------|
| 1.     | Resistances            |                  |          |         |
| 2.     | Breadboard             |                  |          |         |
| 3.     | Power supply           | 0 -30 v 1 Amp DC |          |         |
| 4.     | Connecting leads       |                  |          |         |
| 5.     | Voltmeter              | 0 -50 V          |          |         |
| 6.     | Ammeter                | 1 Amp            |          |         |

**X Precautions**

1. Keep the resistances at maximum position
2. Check the connection before connecting circuit to supply
3. Apply voltage as per rating of the resistors, ammeter

**XI Procedure:**

1. Connect the circuit as shown in figure 1
2. First keep the output terminals open & connect the 5V supply to Input terminals
3. Read ammeter reading for I1
4. Read voltmeter reading for V2
5. Switch off the supply
6. Connect the circuit as shown in figure 2
7. First short the output terminals & connect the 5V supply to Input terminals
8. Read ammeter reading for I1
9. Read ammeter reading for I2

**XII Resources used (with major specifications)**

| S. No. | Instrument /Components | Specification | Quantity |
|--------|------------------------|---------------|----------|
| 1.     |                        |               |          |
| 2.     |                        |               |          |
| 3.     |                        |               |          |
| 4.     |                        |               |          |
| 5.     |                        |               |          |
| 6.     |                        |               |          |

**XIII Actual procedure followed**

.....

.....

.....

.....

.....

.....

**XIV Precautions followed**

.....

.....

.....

**XV Observations and Calculations:**

**Table 17.1: Observed value of A, B, C, D parameters**

| Sr. No. | V1(V) | V2(V) | I1(A) | I2(A) | Parameter                          | Observed Value |
|---------|-------|-------|-------|-------|------------------------------------|----------------|
| 1       |       |       | -     | 0     | <b>A</b>                           |                |
| 2       |       | 0     | -     |       | <b>B(<math>\Omega</math>)</b>      |                |
| 3       | -     |       |       | 0     | <b>C(<math>\Omega^{-1}</math>)</b> |                |
| 4       | -     | 0     |       |       | <b>D</b>                           |                |

**Calculations:**

**XVI Results**

.....  
 .....  
 .....

**XVII Interpretation of results:**

.....  
 .....  
 .....

**XVIII Conclusions and Recommendation:**

.....  
 .....  
 .....

**XIX Practical related Questions**

1. Why we can call the network as transmission network
2. Can we perform the experiment with ac supply also? Justify.
3. Can we find the values without supply?

**[Space for Answers]**

.....  
 .....



.....

.....

.....

.....

.....

.....

**XX References / Suggestions for further Reading**

Author: V.K. MEHTA, ROHIT MEHTA, Title: Basic Electrical Engineering, Publisher: S. Chand & Co.

**XXI Assessment Scheme**

| Performance indicators            |   | Weightage    |
|-----------------------------------|---|--------------|
| <b>Process related (10 Marks)</b> |   | <b>40%</b>   |
| 1                                 | Selection of equipment, components, instruments | 10%          |
| 2                                 | Proper connection of circuit                    | 10%          |
| 3                                 | Neatness in the arrangement of circuit          | 10%          |
| 4                                 | Procedural steps followed                       | 10%          |
| <b>Product related (15 Marks)</b> |   | <b>60%</b>   |
| 5                                 | Accuracy in calculations                        | 20%          |
| 6                                 | Representation of phasor diagram                | 20%          |
| 7                                 | Interpretation of results                       | 10%          |
| 8                                 | Conclusion                                      | 05%          |
| 9                                 | Submitting the journal in time                  | 05%          |
| <b>Total (25 Marks)</b>           |   | <b>100 %</b> |

***Names of Student Team Members***

1. ....
2. ....
3. ....
4. ....

| Marks Obtained      |                     |            | Dated signature of Teacher |
|---------------------|---------------------|------------|----------------------------|
| Process Related(15) | Product Related(10) | Total (25) |                            |
|                     |                     |            |                            |

## List Of Laboratory Manuals Developed by MSBTE

### First Semester:

|   |                           |       |
|---|---------------------------|-------|
| 1 | Fundamentals of ICT       | 22001 |
| 2 | English                   | 22101 |
| 3 | English Work Book         | 22101 |
| 4 | Basic Science (Chemistry) | 22102 |
| 5 | Basic Science (Physics)   | 22102 |

### Second Semester:

|    |   |       |
|----|---|-------|
| 1  | Business Communication Using Computers      | 22009 |
| 2  | Computer Peripherals & Hardware Maintenance | 22013 |
| 3  | Web Page Design with HTML                   | 22014 |
| 4  | Applied Science (Chemistry)                 | 22202 |
| 5  | Applied Science (Physics)                   | 22202 |
| 6  | Applied Machines                            | 22203 |
| 7  | Basic Surveying                             | 22205 |
| 8  | Applied Science (Chemistry)                 | 22211 |
| 9  | Applied Science (Physics)                   | 22211 |
| 10 | Fundamental of Electrical Engineering       | 22212 |
| 11 | Elements of Electronics                     | 22213 |
| 12 | Elements of Electrical Engineering          | 22215 |
| 13 | Basic Electronics                           | 22216 |
| 14 | 'C' programming Language                    | 22218 |
| 15 | Basic Electronics                           | 22225 |
| 16 | Programming in "C"                          | 22226 |
| 17 | Fundamentals of Chemical Engineering        | 22231 |

### Third Semester:

|    |   |       |
|----|---|-------|
| 1  | Applied Multimedia Techniques             | 22024 |
| 2  | Advanced Surveying                        | 22301 |
| 3  | Highway Engineering                       | 22302 |
| 4  | Mechanics of Structures                   | 22303 |
| 5  | Building Construction                     | 22304 |
| 6  | Concrete Technology                       | 22305 |
| 7  | Strength Of Materials                     | 22306 |
| 8  | Automobile Engines                        | 22308 |
| 9  | Automobile Transmission System            | 22309 |
| 10 | Mechanical Operations                     | 22313 |
| 11 | Technology Of Inorganic Chemicals         | 22314 |
| 12 | Object Oriented Programming Using C++     | 22316 |
| 13 | Data Structure Using 'C'                  | 22317 |
| 14 | Computer Graphics                         | 22318 |
| 15 | Database Management System                | 22319 |
| 16 | Digital Techniques                        | 22320 |
| 17 | Principles Of Database                    | 22321 |
| 18 | Digital Techniques & Microprocessor       | 22323 |
| 19 | Electrical Circuits                       | 22324 |
| 20 | Electrical & Electronic Measurement       | 22325 |
| 21 | Fundamental Of Power Electronics          | 22326 |
| 22 | Electrical Materials & Wiring Practice    | 22328 |
| 23 | Applied Electronics                       | 22329 |
| 24 | Electrical Circuits & Networks            | 22330 |
| 25 | Electronic Measurements & Instrumentation | 22333 |
| 26 | Principles Of Electronics Communication   | 22334 |
| 27 | Thermal Engineering                       | 22337 |
| 28 | Engineering Metrology                     | 22342 |
| 29 | Mechanical Engineering Materials          | 22343 |
| 30 | Theory Of Machines                        | 22344 |

### Fourth Semester:

|    |  |       |
|----|--|-------|
| 1  | Hydraulics   | 22401 |
| 2  | Geo Technical Engineering                            | 22404 |
| 3  | Chemical Process Instrumentation & Control           | 22407 |
| 4  | Fluid Flow Operation                                 | 22409 |
| 5  | Technology Of Organic Chemicals                      | 22410 |
| 6  | Java Programming                                     | 22412 |
| 7  | GUI Application Development Using VB.net             | 22034 |
| 8  | Microprocessor                                       | 22415 |
| 9  | Database Management                                  | 22416 |
| 10 | Electric Motors And Transformers                     | 22418 |
| 11 | Industrial Measurements                              | 22420 |
| 12 | Digital Electronics And Microcontroller Applications | 22421 |
| 13 | Linear Integrated Circuits                           | 22423 |
| 14 | Microcontroller & Applications                       | 22426 |
| 15 | Basic Power Electronics                              | 22427 |

|    |                                     |       |
|----|-------------------------------------|-------|
| 16 | Digital Communication Systems       | 22428 |
| 17 | Mechanical Engineering Measurements | 22443 |
| 18 | Fluid Mechanics and Machinery       | 22445 |
| 19 | Fundamentals Of Mechatronics        | 22048 |

### Fifth Semester:

|    |   |       |
|----|---|-------|
| 1  | Design of Steel and RCC Structures                                      | 22502 |
| 2  | Public Health Engineering   | 22504 |
| 3  | Heat Transfer Operation   | 22510 |
| 4  | Environmental Technology  | 22511 |
| 5  | Operating Systems   | 22516 |
| 6  | Advanced Java Programming   | 22517 |
| 7  | Software Testing  | 22518 |
| 8  | Control Systems and PLC's   | 22531 |
| 9  | Embedded Systems  | 22532 |
| 10 | Mobile and Wireless Communication                                       | 22533 |
| 11 | Industrial Machines   | 22523 |
| 12 | Switchgear and Protection   | 22524 |
| 13 | Energy Conservation and Audit   | 22525 |
| 14 | Power Engineering and Refrigeration                                     | 22562 |
| 15 | Solid Modeling and Additive Manufacturing                               | 22053 |
| 16 | Guidelines & Assessment Manual for Micro Projects & Industrial Training | 22057 |

### Sixth Semester:

|    |  |       |
|----|--|-------|
| 1  | Solid Modeling                                 | 17063 |
| 2  | Highway Engineering                            | 17602 |
| 3  | Contracts & Accounts                           | 17603 |
| 4  | Design of R.C.C. Structures                    | 17604 |
| 5  | Industrial Fluid Power                         | 17608 |
| 6  | Design of Machine Elements                     | 17610 |
| 7  | Automotive Electrical and Electronic Systems   | 17617 |
| 8  | Vehicle Systems Maintenance                    | 17618 |
| 9  | Software Testing                               | 17624 |
| 10 | Advanced Java Programming                      | 17625 |
| 11 | Mobile Computing                               | 17632 |
| 12 | System Programming                             | 17634 |
| 13 | Testing & Maintenance of Electrical Equipments | 17637 |
| 14 | Power Electronics                              | 17638 |
| 15 | Illumination Engineering                       | 17639 |
| 16 | Power System Operation & Control               | 17643 |
| 17 | Environmental Technology                       | 17646 |
| 18 | Mass Transfer Operation                        | 17648 |
| 19 | Advanced Communication System                  | 17656 |
| 20 | Mobile Communication                           | 17657 |
| 21 | Embedded System                                | 17658 |
| 22 | Process Control System                         | 17663 |
| 23 | Industrial Automation                          | 17664 |
| 24 | Industrial Drives                              | 17667 |
| 25 | Video Engineering                              | 17668 |
| 26 | Optical Fiber & Mobile Communication           | 17669 |
| 27 | Therapeutic Equipment                          | 17671 |
| 28 | Intensive Care Equipment                       | 17672 |
| 29 | Medical Imaging Equipment                      | 17673 |

### Pharmacy Lab Manual

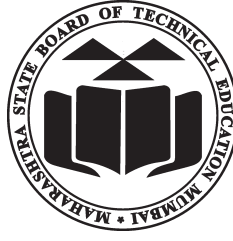
#### First Year:

|   |                                     |      |
|---|-------------------------------------|------|
| 1 | Pharmaceutics - I                   | 0805 |
| 2 | Pharmaceutical Chemistry - I        | 0806 |
| 3 | Pharmacognosy                       | 0807 |
| 4 | Biochemistry and Clinical Pathology | 0808 |
| 5 | Human Anatomy and Physiology        | 0809 |

#### Second Year:

|   |                                |      |
|---|--------------------------------|------|
| 1 | Pharmaceutics - II             | 0811 |
| 2 | Pharmaceutical Chemistry - II  | 0812 |
| 3 | Pharmacology & Toxicology      | 0813 |
| 4 | Hospital and Clinical Pharmacy | 0816 |

## HEAD OFFICE



Secretary,

Maharashtra State Board of Technical Education

49, Kherwadi, Bandra (East), Mumbai - 400 051

Maharashtra (INDIA)

Tel: (022)26471255 (5 -lines)

Fax: 022 - 26473980

Email: -secretary@msbte.com

**Web -[www.msbte.org.in](http://www.msbte.org.in)**

## REGIONAL OFFICES:

### MUMBAI

Deputy Secretary (T),  
Mumbai Sub-region,  
2<sup>nd</sup> Floor, Govt. Polytechnic Building,  
49, Kherwadi, Bandra (East)  
Mumbai - 400 051  
Phone: 022-26473253 / 54  
Fax: 022-26478795  
Email: rbtemumbai@msbte.com

### PUNE

Deputy Secretary (T),  
M.S. Board of Technical Education,  
Regional Office,  
412-E, Bahirat Patil Chowk,  
Shivaji Nagar, Pune  
Phone: 020-25656994 / 25660319  
Fax: 020-25656994  
Email: rbtepn@msbte.com

### NAGPUR

Deputy Secretary (T),  
M.S. Board of Technical Education  
Regional Office,  
Mangalwari Bazar, Sadar, Nagpur - 440 001  
Phone: 0712-2564836 / 2562223  
Fax: 0712-2560350  
Email: rbteeng@msbte.com

### AURANGABAD

Deputy Secretary (T),  
M.S. Board of Technical Education,  
Regional Office,  
Osmanpura, Aurangabad -431 001.  
Phone: 0240-2334025 / 2331273  
Fax: 0240-2349669  
Email: rbteau@msbte.com