

0



Zeal Education Society's
**ZEAL POLYTECHNIC,
PUNE.**

NARHE | PUNE -41 | INDIA

FIRST YEAR (FY)

DIPLOMA IN CIVIL ENGINEERING

SCHEME: I

SEMESTER: IV

NAME OF SUBJECT: Building Planning and Drawing

Subject Code: 22405

MSBTE QUESTION PAPERS & MODEL ANSWERS

1. MSBTE SUMMER-19 EXAMINATION

2. MSBTE WINTER-19 EXAMINATION

22405

21819

4 Hours / 70 Marks

Seat No.

--	--	--	--	--	--	--	--	--

- Instructions :**
- (1) All Questions are *compulsory*.
 - (2) Answer each next main Question on a new page.
 - (3) Illustrate your answers with neat sketches wherever necessary.
 - (4) Figures to the right indicate full marks.
 - (5) Assume suitable data, if necessary.
 - (6) Use of Non-programmable Electronic Pocket Calculator is permissible.
 - (7) Mobile Phone, Pager and any other Electronic Communication devices are not permissible in Examination Hall.

Marks

1. **Attempt any THREE of the following :** **12**
 - (a) Draw graphical symbols for (1) Concrete (2) Wood work (3) Sliding door (4) UCR Masonary
 - (b) Draw neat sketches for following lines
(1) Section line (2) Hidden line (3) Dimension line (4) Extension line
 - (c) Define Orientation and Grouping in Principles of Planning.
 - (d) State the importance of site plan and openings schedule in civil engineering drawing.
 - (e) Give the necessity of perspective drawing.

2. Draw to suitable scale the line plan of bank building. Label all units with their sizes. Clearly indicate position of openings. **10**

- 3. Attempt the following :** **12**
- Fig. No. 1 show a line plan of residential building. Draw to a scale of 1 : 50 the developed plan. Show all dimensions and label the units. Use following data plinth height 600 mm.
- Super structure in Brick Masonary with walls 300 mm thick and internal walls for bath and W.C. 100 mm thick.
- Assume Chajja projection 450 mm. Assume suitable data if necessary.
- 4. Attempt any TWO of the following :** **12**
- (a) Write any four purposes of construction notes and any two purposes of north line.
- (b) Explain important rules and byelaws of sanctioning authorities for construction in rural area.
- (c) Draw a neat sketch showing RCC components of lintel with 1 : 20 scale.
- 5. Attempt any TWO of the following :** **12**
- (a) Prepare schedule of openings in the standard format and area statement for building in Q. No. 2.
- (b) Enlist units of primary Health Center and write minimum dimension of each unit.
- (c) List any three purposes of submission drawing and working drawing in civil engineering works.
- 6. Attempt any ONE of the following :** **12**
- (a) Draw to a suitable scale two point perspective drawing of the object shown below in fig. No.2 or fig. No. 3. Assume eye level 1.5 m above GL and station point at 3.0 m from PP. Retain all construction lines.
- (b) Draw a plan and section of a single flight of a RCC stair case from the following data :
- Number of risers - 10 of 160 mm height
Number of treads - 9 of 250 mm height
Width of stairs case is 1000 mm
Landing at top is 1000 × 1000 mm.
-



**MAHARASHTRA STATE BOARD OF TECHNICAL EDUCATION
(Autonomous)**

(ISO/IEC -270001 – 2005 certified)

SUMMER -2019 EXAMINATION





Subject code: 22405



Model Answer

Page No: 01/ 07

Important Instructions to examiners:

- 1) The answer should be examined by keywords and not as word-to-word as given in the model answer scheme.
- 2) The model answer and the answer written by candidate may vary but the examiner may try to assess the understanding level of the candidate.
- 3) The language error such as grammatical, spelling errors should not be given more importance. (Not applicable for subject English and communication skill).
- 4) While assessing figures, examiner may give credit for principal components indicated in the figure. The figure drawn by candidate and model answer may vary. The examiner may give credit for any equivalent figure drawn.
- 5) Credits may be given stepwise for numerical problems. In the some cases, the assumed constants values may vary and there may be some difference in the candidates answer and model answer.
- 6) In case of some questions credit may be given by judgment on part of examiner of relevant answer based on candidates understanding

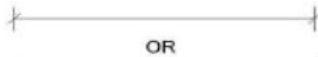
Q.No.	Question and Model Answers	Marks
Q.1	Answer any THREE of the following:	12M
(a)	Draw Graphical Symbols for (1) Concrete (2) Wood work (3) Sliding door (4) UCR Masonry	4M
	<p>Ans: Graphical Symbols for-</p> <p>(1) Concrete </p> <p>(2) Wood work </p> <p>(3) Sliding door </p> <p>(4) UCR Masonry </p> <p style="text-align: center;"><i>*(Note- 01 mark each)</i></p>	1M each
(b)	Draw neat sketches for following lines (1) Section line (2) Hidden line (3) Dimension line (4) Extension line	4M
	<p>Ans:</p> <p>(a) Hidden Line </p>	1M each

	<p>(b) Section Line </p> <p>(c) Dimension Line </p> <p>(d) Extension Line </p>	
(c)	Define orientation and grouping Principles of Planning.	4M
	<p>Ans:</p> <p>(1) Orientation: Orientation is the method of proper placement of planned unit of the building in relation to natural elements like sun, rain, wind, topography, etc. The position of building is decided with respect to North to place the different units of room to achieve natural ventilation, air circulation and lighting.</p> <p>(2) Grouping: It is an arrangement of various rooms with reference to their functions or in other words, making group of units of building depending upon their functional co-relations.</p>	<p>2M</p> <p>2M</p>
(d)	State the importance of site plan and openings schedule in civil engineering drawing.	4M
	<p>Ans:</p> <p>Importance of Site plan –</p> <ol style="list-style-type: none"> 1) It gives idea of site i.e. plot size and size or shape of proposed building. 2) It is helpful to calculate plot area and plinth area. 3) It gives details of side margins. 4) It shows adjacent road and road width. 5) With north direction, plot orientation can be decided. 6) It gives idea about water & drainage line. 7) It shows adjacent plots, survey number, plot number, nearby permanent structure like temple, etc. <p>Importance of openings schedule or schedule of openings –</p> <ol style="list-style-type: none"> 1) To check opening area for ventilation. 2) To know the type of openings proposed. 3) To give purchase order. 4) To give the details and number of opening or gates to the fabricator. 5) For billing purpose. 6) To make alteration in type of opening, if required. 	<p>2M (for any four points)</p> <p>2M (for any four points)</p>
(e)	Give the necessity of perspective drawing.	4M
	<p>Ans:</p> <p>Necessity of perspective drawing –</p> <ol style="list-style-type: none"> 1) Perspective drawing gives a three dimensional feeling of a flat image. 2) It is helpful for architects or designer to decide the elevation and overall structure's look. 3) It is helpful for the owner to get idea about how the building will look after construction. 	<p>4M (for any four points)</p>

- 4) It is required for model making of the building.
- 5) It is necessary for advertisements of commercial projects.
- 6) It helps in landscaping around the structure.

Q.2 Draw to suitable scale the line plan of bank building. Label all units with their sizes. Clearly indicate position of openings.

10M

Ans:

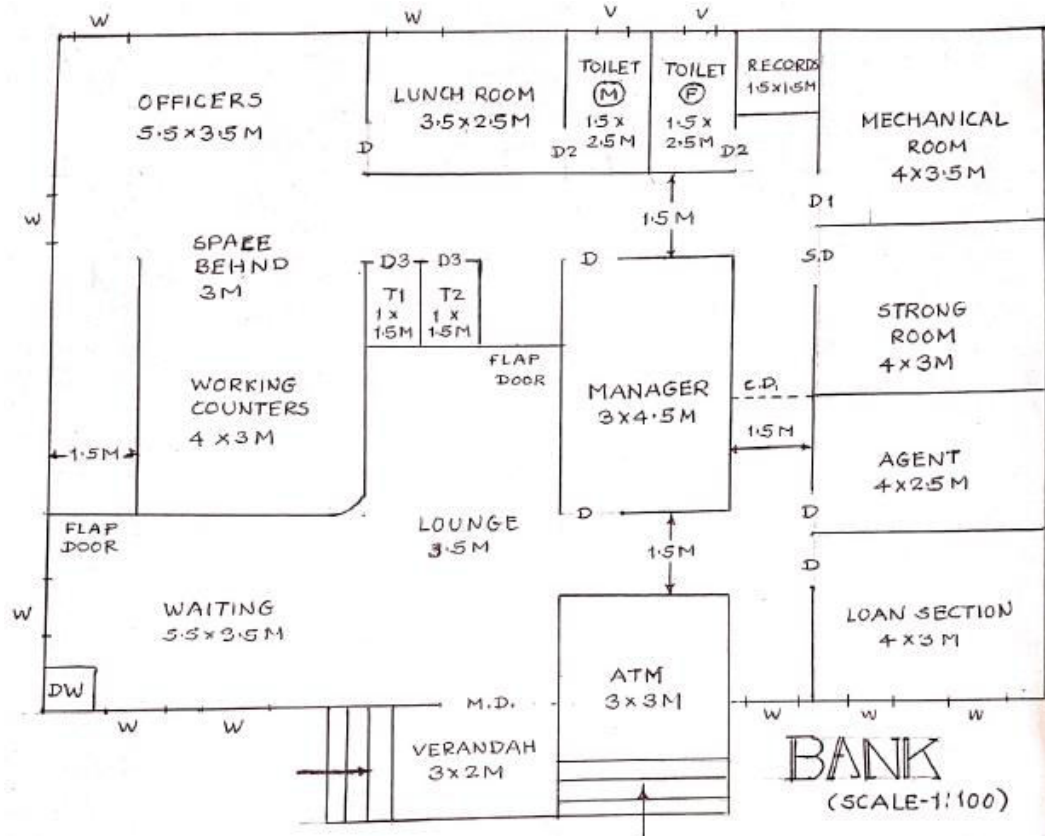

10M*

Bank

**(Note- for neat and suitable line plan with scale 05 marks, for proper sizes – 02 marks, for door and window position -02 marks and 01 mark for labeling)*

Important Note: Student may draw any other line plan of Bank Building. So give credit accordingly.

Q.3 Fig. No. 1 shows a line plan of a residential building. Draw to a Scale of 1:50, the developed plan. Show all dimensions and label the units. Use following data. Plinth height 600 mm.

12M

Super structure in Brick Masonary with walls 300 mm thick and internal walls for bath and WC 100 mm thick.
Assume Chajja Projection 450 mm. Assume suitable data if necessary.

Important Note:

As fig. No. 1 is not given in the question paper,

Not to assess and give ZERO marks.

Q.4	Attempt any TWO of the following:	12M
(a)	Write any four purposes of construction notes and any two purposes of north line.	6M
	<p>Ans: Purposes of Construction notes – 1) These include additional information about the structure which can not be shown in drawing. 2) These are useful for better understanding of drawing. 3) To give idea about any special work. 4) To know materials, finishes, thickness, proportions, etc. 5) To avoid any confusions. 6) To provide information about finishing work, especially like flooring, colouring, pointing, ornamental work etc., which is difficult to show in drawing.</p> <p>Purposes of North direction – 1) For orientation of Building. 2) It helps in planning of various units and their placement. 3) To keep uniformity in drawing with common reference direction. 4) To avoid discrepancies in understanding of drawing.</p>	<p>4M (for any four)</p> <p>2M (for any two)</p>
(b)	Explain important rules and byelaws of sanctioning authorities for construction in rural area.	6M
	<p>Ans: Important rules and byelaws of sanctioning authorities for construction in rural area are – 1) The minimum height of plinth shall be regulated on the basis of environmental and topographical condition and higher plinth height may be required in areas prone to flooding. 2) Every dwelling unit to be provided should have at least two habitable rooms. First room shall not be less than 9.0 m² with minimum width of 2.5 m and second room shall not be less than 6.5 m² with a minimum width of 2.1 m provided the total area of both the rooms is not less than 15.5 m². 3) The minimum size of such a mezzanine floor should not be lesser than 6.5 m² and such a floor should occupy not more than 50 percent of room area. 4) Minimum clear height below and above the mezzanine floor should be 2.4 m and 2.1 m respectively. 5) The size of independent water-closet shall be 0.9 m²; with minimum width of 90 cm. 6) The size of independent bathroom shall be 1.2 m with minimum width 1m. 7) The size of a cooking alcove serving as cooking space shall not be less than 2.4 m² with a minimum width of 1.2 m. 8) The minimum height of rooms/spaces shall be a) Habitable room 2.75 m, b) Kitchen 2.6 m, c) Bath/water-closet 2.2 m, d) Corridor 2.1 m 9) One water tap per dwelling unit may be provided, where adequate drinking water supply is available. 10) Water from drains shall be connected to village ponds and appropriate eco-friendly methods like growing of duck weed plants shall be adopted to treat waste water.</p> <p>*(Note- Student may write byelaws in municipal area. Give credit to any six.)</p>	6M* (for any six)

(c)	Draw a neat sketch showing RCC components of lintel with 1:20 scale.	6M																																													
	<p>Ans:</p> <p style="text-align: center;">RCC components of Lintel</p> <p style="text-align: right;">(Scale 1:20)</p> <p style="text-align: center;"><i>*(Note-for L-section 02 marks, cross section 02 marks, 01 mark for scale, 01 mark for labeling)</i></p>	6M*																																													
Q.5	Attempt any TWO of the following :	12M																																													
(a)	Prepare schedule of openings in the standard format and area statement for building in Q. No. 2.	6M																																													
	<p>Ans:</p> <p style="text-align: center;">For Bank building in Q.NO.2</p> <p>Schedule of Openings –</p> <table border="1" data-bbox="256 994 1321 1375"> <thead> <tr> <th>Sr.No.</th> <th>Symbol</th> <th>Description</th> <th>Size in m</th> <th>Nos.</th> </tr> </thead> <tbody> <tr> <td>1</td> <td>M.D.</td> <td>Fully Glass Panelled door (with Collapsible door and Rolling Shutter)</td> <td>2.0 x 2.5</td> <td>1</td> </tr> <tr> <td>2</td> <td>D</td> <td>Partially paneled and partially glazed.</td> <td>1.0 x 2.1</td> <td>5</td> </tr> <tr> <td>2</td> <td>D1</td> <td>Flush door</td> <td>1.0 x 2.1</td> <td>1</td> </tr> <tr> <td>3</td> <td>D2</td> <td>Flush door or PVC door</td> <td>0.9 x 2.1</td> <td>2</td> </tr> <tr> <td>4</td> <td>S.D.</td> <td>Heavy steel door with safety grill</td> <td>1.2 x 2.0</td> <td>1</td> </tr> <tr> <td>5</td> <td>C.D.</td> <td>Collapsible Gate with grill above</td> <td>1.5 x 2.4</td> <td>1</td> </tr> <tr> <td>6</td> <td>W</td> <td>T.W. Panelled window</td> <td>1.2 x 1.4</td> <td>9</td> </tr> <tr> <td>7</td> <td>V</td> <td>Louvered window</td> <td>0.5 x 0.7</td> <td>2</td> </tr> </tbody> </table> <p style="text-align: center;"><i>*(Note- for Correct Symbols - 01 mark, Opening type - 03 marks, Opening sizes - 03 marks, No. of openings – 01 Mark)</i></p> <p style="text-align: center;"><u>Important Note: Student may take another type of door or window, with different sizes, give credits accordingly.</u></p> <p>Area Statement –</p> <p>1) Plot area (Assuming front margin as 4 M and all other as 3 M) $= (12 + 4 + 3) \times (17.5 + 3 + 3)$ $= 19 \times 23.5$ $= 446.5 \text{ Sq.M.}$</p> <p>2) Built up Area = 15% more of floor area $= \text{approx. } [(17.5 \times 12) + (3 \times 1.5)] \times 1.15$ $= 246.675 \text{ Sq.M.}$</p> <p>3) F.S.I. allowed = 1</p> <p>4) F.S.I. Consumed = Built up area/ Plot area $= 246.675/446.5$ $= 0.55$</p>	Sr.No.	Symbol	Description	Size in m	Nos.	1	M.D.	Fully Glass Panelled door (with Collapsible door and Rolling Shutter)	2.0 x 2.5	1	2	D	Partially paneled and partially glazed.	1.0 x 2.1	5	2	D1	Flush door	1.0 x 2.1	1	3	D2	Flush door or PVC door	0.9 x 2.1	2	4	S.D.	Heavy steel door with safety grill	1.2 x 2.0	1	5	C.D.	Collapsible Gate with grill above	1.5 x 2.4	1	6	W	T.W. Panelled window	1.2 x 1.4	9	7	V	Louvered window	0.5 x 0.7	2	3M*
Sr.No.	Symbol	Description	Size in m	Nos.																																											
1	M.D.	Fully Glass Panelled door (with Collapsible door and Rolling Shutter)	2.0 x 2.5	1																																											
2	D	Partially paneled and partially glazed.	1.0 x 2.1	5																																											
2	D1	Flush door	1.0 x 2.1	1																																											
3	D2	Flush door or PVC door	0.9 x 2.1	2																																											
4	S.D.	Heavy steel door with safety grill	1.2 x 2.0	1																																											
5	C.D.	Collapsible Gate with grill above	1.5 x 2.4	1																																											
6	W	T.W. Panelled window	1.2 x 1.4	9																																											
7	V	Louvered window	0.5 x 0.7	2																																											
		3M																																													

	<u>Important Note: Student may take another side margin or different % for built up area, give credits accordingly.</u>																
(b)	Enlist various units of primary Health Center and write minimum dimension of each unit.	6M															
	<p>Ans: Units required for <u>Primary health centre:</u></p> <ol style="list-style-type: none"> Entrance or reception - 2.5 m wide Doctor's Room – 3 m x 3.6 m Examination Room – 3 m x 4 m Operation Theatre – 4 m x 5.5 m Circulation Space – 3 m wide Laboratory – 15 sq. m Ward (general/ maternity) – area 8 to 10 sq. m per bed Medical Store or Pharmacy – 3 x 4.5 m Office – 12 sq. m Family Planning Unit – 3 m x 4 m Parking - Scooter/ Motorcycle – 3 sq.m./ vehicle, Cycle- 1.2 sq.m./ cycle Sanitary block <table border="1" style="margin-left: auto; margin-right: auto;"> <thead> <tr> <th>Unit</th> <th>Male</th> <th>Female</th> </tr> </thead> <tbody> <tr> <td>W.C.</td> <td>1 in 100</td> <td>1 in 50</td> </tr> <tr> <td>Urinal</td> <td>1 in 50</td> <td>---</td> </tr> <tr> <td>Wash basin</td> <td>1 in 100</td> <td>1 in 100</td> </tr> <tr> <td>Bath</td> <td>2 per ward</td> <td>2 per ward</td> </tr> </tbody> </table> <p style="text-align: center;"><u>*(Note- 1/2 mark for stating six units and 1/2 mark for their respective minimum sizes. i.e. 3 + 3 = 6 marks.)</u></p>	Unit	Male	Female	W.C.	1 in 100	1 in 50	Urinal	1 in 50	---	Wash basin	1 in 100	1 in 100	Bath	2 per ward	2 per ward	6M* (for any six)
Unit	Male	Female															
W.C.	1 in 100	1 in 50															
Urinal	1 in 50	---															
Wash basin	1 in 100	1 in 100															
Bath	2 per ward	2 per ward															
(c)	List any three purposes of submission drawing and working drawing in civil engineering works.	6M															
	<p>Ans:</p> <p>Purposes of submission drawing –</p> <ol style="list-style-type: none"> To get sanction from competent authority before starting actual work. To check whether the proposed construction is as per bye-laws or not. To decide the taxation of building by municipal authority. Without sanction of submission drawing, any construction, if constructed is illegal. To regularize the construction as per bye laws. <p>Purposes of working drawing –</p> <ol style="list-style-type: none"> To carry out actual construction work. To get better idea of work. To know the sizes of R.C.C. sections, steel reinforcement, etc. To understand the exact nature of work. To carry out the work as per design. To check the work carried out and record measurements. 	1M each (for any three)															
Q.6	Attempt any ONE of the following:	12M															
(a)	Draw to a suitable scale a two point perspective drawing of the object shown below in fig. No. 2 or fig. No. 3. Assume eye level 1.5 m above G.L. and station point at 3.0 m from PP. Retain all construction lines.	12M															

Ans:

Important Note:
As fig. No. 2 and fig. No. 3 are not given in the question paper,
Not to assess and give ZERO marks.

- (b) Draw a plan and section of a single flight of a R.C.C. stair case from following data:
 Number of risers- 10 of 160 mm height
 Number of treads – 9 of 250 mm height
 Width of stair case is 1000 mm
 Landing at top is 1000 x 1000 mm

12M

Ans:

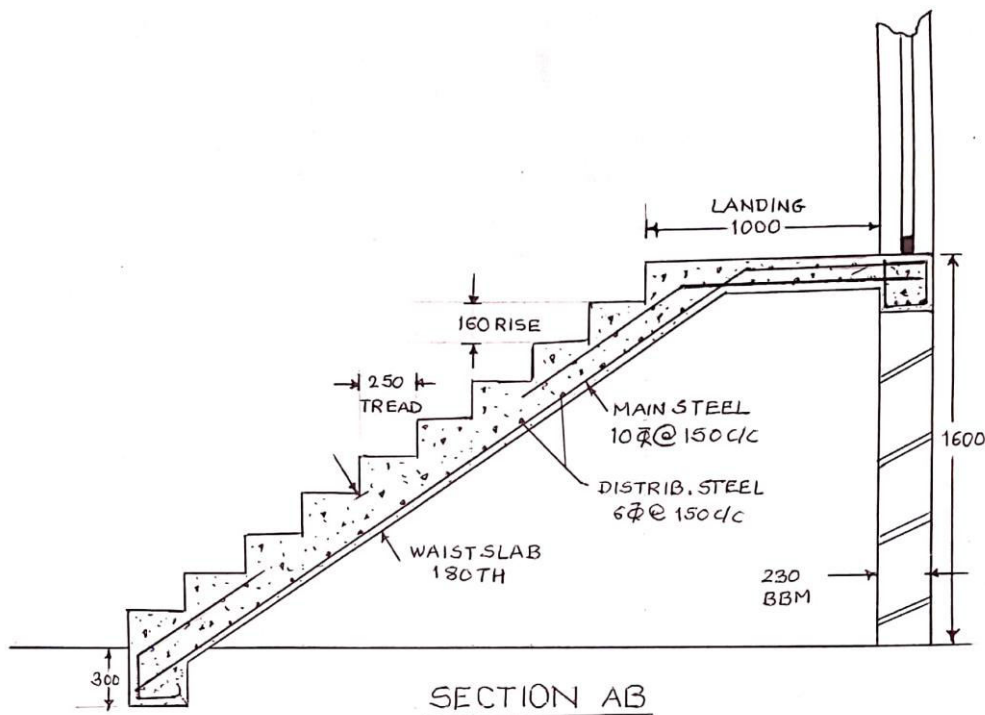

6M*

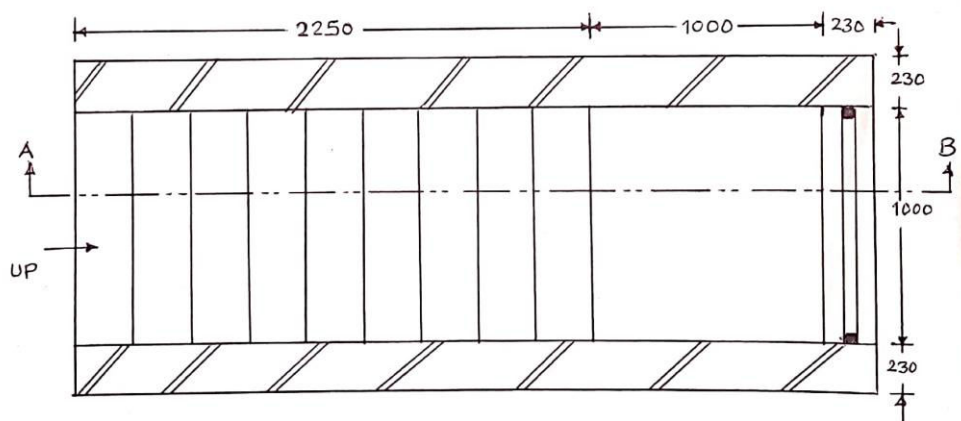

6M*

PLAN (ALL DIMENSIONS IN MM)
 SCALE - 1:25

*(Note- Distribution of 6 marks for plan and section each is as below-
 04 marks for arrangement, 01 mark for dimensions, 01 mark for labeling)

22405

11920

4 Hours / 70 Marks

Seat No.

--	--	--	--	--	--	--	--

- Instructions :**
- (1) All Questions are *compulsory*.
 - (2) Illustrate your answers with neat sketches wherever necessary.
 - (3) Figures to the right indicate full marks.
 - (4) Assume suitable data, if necessary.
 - (5) Use of Non-programmable Electronic Pocket Calculator is permissible.
 - (6) Mobile Phone, Pager and any other Electronic Communication devices are not permissible in Examination Hall.

Marks

1. Attempt any THREE of the following :

3 × 4 = 12

- (a) Draw graphical symbols as per IS 962 – 1989.
 - (i) Brickwork
 - (ii) Partition Block
 - (iii) Wood
 - (iv) Single shutter door
- (b) (i) Suggest suitable scale for following :
 - (1) Location plan
 - (2) Door details
 - (ii) Define prospect and ventilation in principles of planning.
- (c) State the purpose of writing the construction notes in the working drawing.
- (d) Define the terms :
 - (i) Centre of vision
 - (ii) Picture plane
- (e) State the purpose of preparing data drawing and measures drawing. (At least two purposes each)

2. Draw to a suitable scale the line plan of a post office for a taluka place with different units. Also, show position of doors, windows and dimensions of each room. **10**

3. **Attempt the following :** **12**

Fig. No. 1 shows a line plane of residential building. Draw developed plan with suitable scale. Show all dimensions and label the parts.

Given data :

- (1) Super structure consists of B.B. Masonry with walls 230 mm thick and internal walls for bath and W.C. 110 mm thick.
- (2) Assume Chajja projection 450 mm.
- (3) Plinth height 600 mm.
- (4) Width of main door 1.2 m, internal door 0.9 m and window 1.2 m, ventilator/louvres – 0.8 m.

Assume suitable data if necessary.

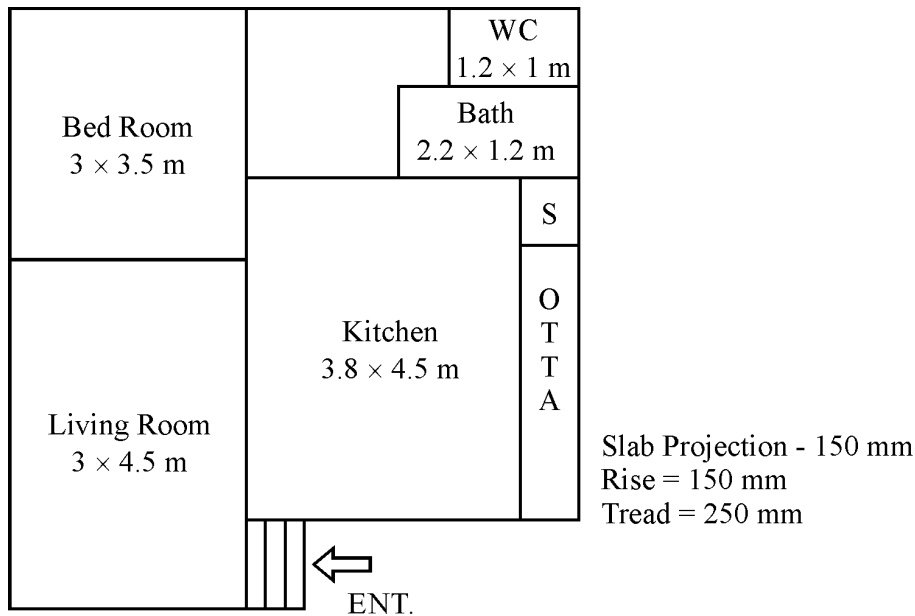

Fig. 1

4. Attempt any TWO of the following :

2 × 6 = 12

- (a) State the importance of submission drawing and working drawing in civil engineering works.
- (b) Prepare schedule of openings and area statement table for fig. No. 1.

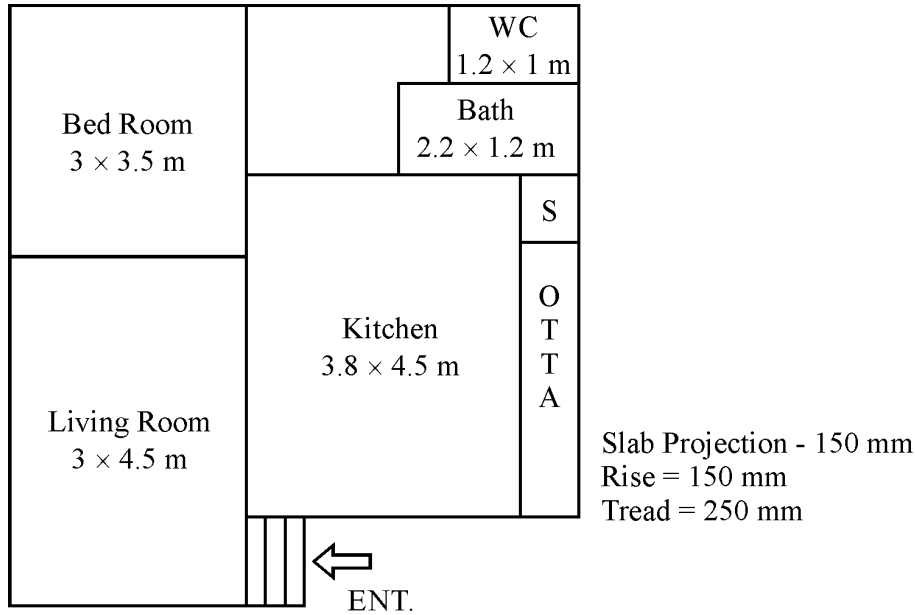

Fig. 1

- (c) Differentiate between load bearing and framed structure.

5. Attempt any TWO of the following :

2 × 6 = 12

- (a) Enlist the various documents and drawings required for municipal sanction.
- (b) Define following :
- Floor Area
 - Super built up Area
 - Carpet Area
- (c) Suggest various units and their sizes for primary health centre for the structure constructed in a village.

6. Attempt any ONE of the following :

1 × 12 = 12

- (a) A plan and elevation of pedestal is shown in fig. No. 2. Corner 'A' touches the picture plane and observer is exactly opposite the corner at 5 m distance. Eye level is 1.5 m. Draw two point perspective with 30-60 angles.

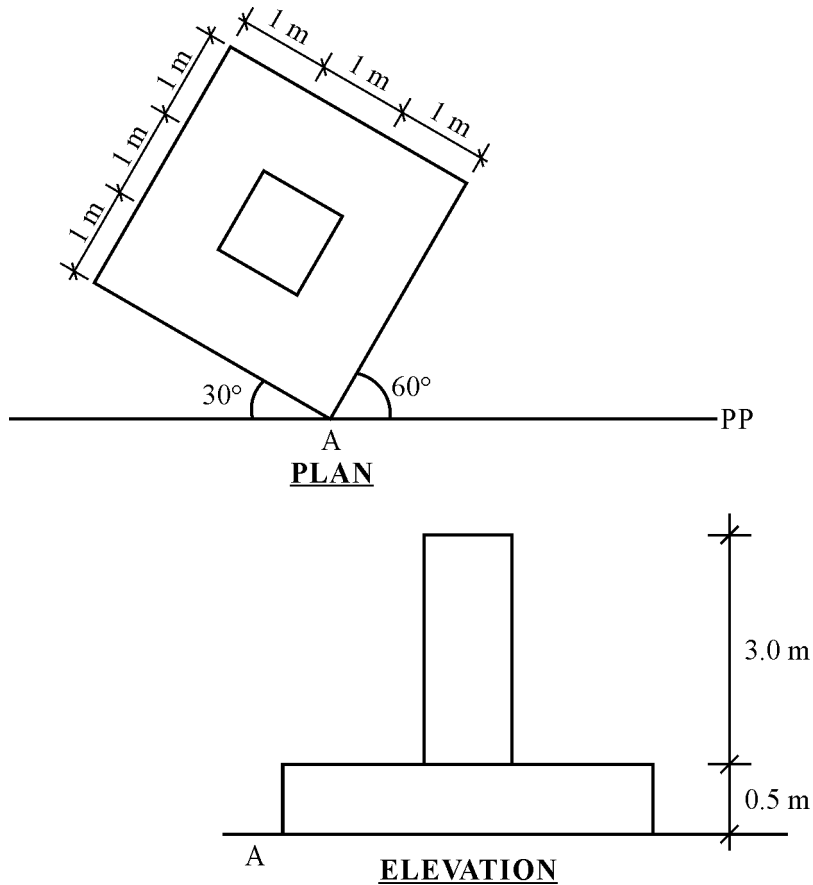

Fig. 2

- (b) Draw a plan and section of single flight of an RCC stair case from following data :
- (i) Number of Risers – 10 Nos. of 160 mm height.
 - (ii) Number of treads – 9 Nos. of 250 mm width
 - (iii) Width of stair case – 1000 mm
 - (iv) Landing at top is – 1000 × 1000 mm



MAHARASHTRA STATE BOARD OF TECHNICAL EDUCATION
(Autonomous)

(ISO/IEC -270001 – 2005 certified)

WINTER -2019 EXAMINATION



Subject code: **22405**

Model Answer

Total Pages - 09

Important Instructions to examiners:

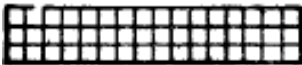
- 1) The answers should be examined by keywords and not as word-to-word as given in the model answer scheme.
- 2) The model answer and the answer written by candidate may vary but the examiner may try to assess the understanding level of the candidate.
- 3) The language error such as grammatical, spelling errors should not be given more importance. (Not applicable for subject English and communication skill).
- 4) While assessing figures, examiner may give credit for principal components indicated in the figure. The figure drawn by candidate and model answer may vary. The examiner may give credit for any equivalent figure drawn.
- 5) Credits may be given step wise for numerical problems. In the some cases, the assumed constant values may vary and there may be some difference in the candidate's answer and model answer.
- 6) In case of some questions credit may be given by judgment on part of examiner of relevant answer based on candidates understanding.
- 7) For programming language papers, credit may be given to any other program based on equivalent concept.

Q. No.	Question and Model Answers	Marks
1.	Attempt any THREE of the following:	3 x 4 = 12
(a)	Draw graphical symbols as per IS 962 – 1989. (i) Brickwork (ii) Partition Block (iii) Wood (iv) Single shutter door	4M
	Ans: Graphical Symbols as per IS 962 – 1989, for- (i) Brickwork  (ii) Partition Block  (iii) Wood  (iv) Single shutter door 	1M each

(b)	(i) Suggest suitable scale for following: (1) Location plan (2) Poor details	2M
	Ans: Suitable scale for- (1) Location plan – 1:1000 (2) Poor details – 1:20 or 1:10 <i>*(Note- if the student has written scale for door details or poor details, as given above, give credit of 01 mark)</i>	1M* each
	(ii) Define prospect and ventilation in principle of planning.	2M
	Ans: Prospect – It is defined as the art of positioning of openings like doors and windows to have a desirable view like gardens, lake, sea, river, mountains, greenery, etc. and blocking un desirable views, such as slums, garbage dump, gutters, railway tracks, etc. Ventilation – It is defined as the circulation of natural air from outside to inside of house and vice a versa. OR Ventilation is the process of fresh air entering a building via a window, door or other opening	1M 1M
(c)	State the purpose of writing the construction notes in the working drawing.	4M
	Ans: Purposes of Construction notes – 1) These include additional information about the structure which can not be shown in drawing. 2) These are useful for better understanding of drawing. 3) To give idea about any special work. 4) To know materials, finishes, thickness, proportions, etc. 5) To avoid any confusions. 6) To provide information about finishing work, especially like flooring, colouring, pointing, ornamental work etc., which is difficult to show in drawing.	4M (for any four)
(d)	Define the terms: (i) Centre of vision (ii) Picture plane	4M
	Ans: (i) Centre of vision The orthographic projection of the station point on the picture plane is called as centre of vision or principal vanishing point. (ii) Picture plane An imaginary transparent plane set up between the observer's eye and the object is called as picture plane.	2M 2M

(e)	<p>State the purpose of preparing data drawing and measures drawing. (At least two purposes each)</p>	<p>4M</p>
	<p>Ans:</p> <p>Purpose of preparing Data drawing –</p> <ol style="list-style-type: none"> 1) Data drawing is necessary to prepare line plan of proposed structure as per requirements of owner like, number of family members, number of units required, sizes, locations, floors required, etc. 2) It is helpful for owner to get better idea of proposed building and finalize the plan or arrangement of units. 3) It helps an architect to prepare detailed drawings. <p>Purpose of Measured Drawing –</p> <ol style="list-style-type: none"> 1) For billing of work. 2) For valuation of building. 3) For altering or making modifications in existing structure. 4) For taking judgement in case of any dispute about area. 	<p>2M (for any two)</p> <p>2M (for any two)</p>
<p>2.</p>	<p>Draw to a suitable scale the line plan of a post office for a taluka place with different units. Also, show position of doors, windows and dimension of each room.</p>	<p>10M</p>
	<p>Ans:</p> <p>POST OFFICE</p> <p>SIZES OF OPENING</p> <p>D' = 2.00X2.50 D = 1.00X2.50 D₁ = 0.70X2.10 W = 1.40X1.50 V = 0.60X0.70 P.B. = POST BOX</p> <p>NOTE:- ALL DIMENSIONS ARE IN METER</p> <p><i>*(Note- for neat and suitable line plan with scale 05 marks, for proper sizes – 02 marks, for door and window position -02 marks and 01 mark for labeling)</i></p> <p><u>Important Note: Student may draw any other line plan of Post office building. So give credit accordingly.</u></p>	<p>10M*</p>

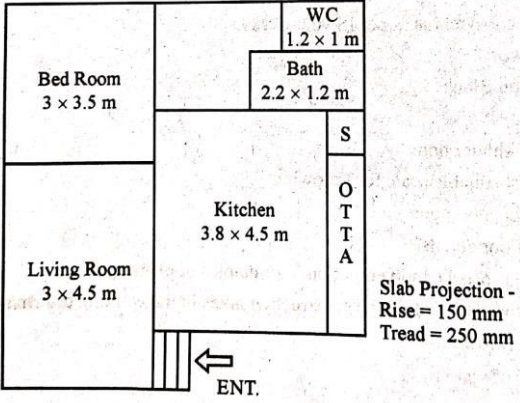
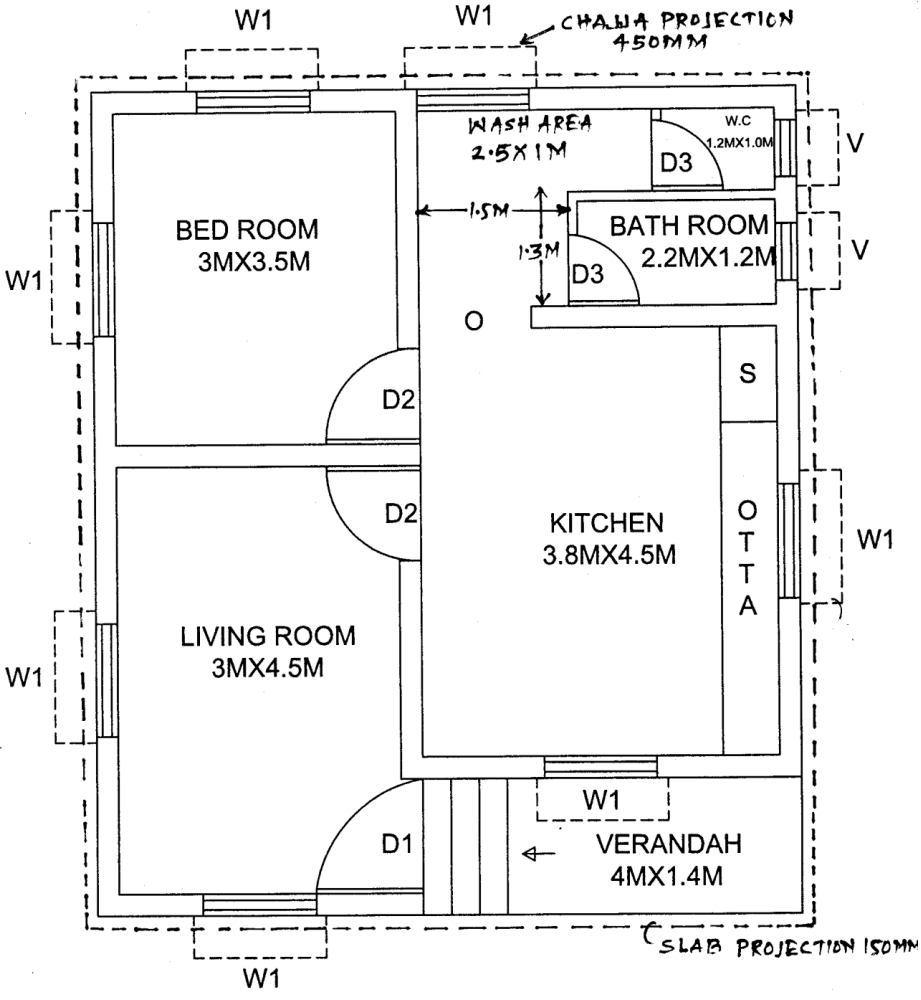
<p>3.</p>	<p>Attempt the following:</p> <p>Fig. No. 1 shows a line plan of residential building. Draw developed plan with suitable scale. Show all dimensions and label the parts.</p> <p>Given data:</p>  <p>(1) Super structure consists of B.B. Masonry with walls 230 mm thick and internal walls for bath and W.C. 110 mm thick.</p> <p>(2) Assume Chajja projection 450 mm.</p> <p>(3) Plinth height 600 mm.</p> <p>(4) Width of main door 1.2 m, internal door of 0.9 m and window 1.2 m, ventilator/louvers – 0.8 m.</p> <p>Assume suitable data if necessary.</p>	<p>12M</p>
<p>Ans:</p>	 <p>DEVELOPED PLAN (SCALE 1:100)</p> <p><i>*(Note- for Wall thickness - 04 marks, Position of Window & Door- 03 marks, Labeling and Dimension- 03 marks, Neatness and Scale – 02 Marks)</i></p>	<p>12M*</p>

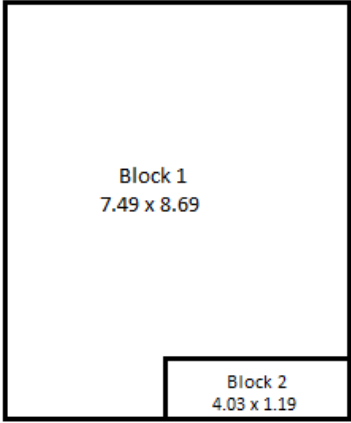
4.	Attempt any TWO of the following:	2 x 6 = 12																																			
(a)	State the importance of submission drawing and working drawing in civil engineering works.	6M																																			
	<p>Ans:</p> <p>Purposes of submission drawing –</p> <ol style="list-style-type: none"> 1) To get sanction from competent authority before starting actual work. 2) To check whether the proposed construction is as per bye-laws or not. 3) To decide the taxation of building by municipal authority. 4) Without sanction of submission drawing, any construction, if constructed is illegal. 5) To regularize the construction as per bye laws. <p>Purposes of working drawing –</p> <ol style="list-style-type: none"> 1) To carry out actual construction work. 2) To get better idea of work. 3) To know the sizes of R.C.C. sections, steel reinforcement, etc. 4) To understand the exact nature of work. 5) To carry out the work as per design. 6) To check the work carried out and record measurements. 	<p>1M each (for any three)</p> <p>1M each (for any three)</p>																																			
(b)	Prepare schedule of openings and area statement table for fig. No. 1.	6M																																			
	<p>Ans:</p> <p style="text-align: center;">For building in Q.NO. 3, Fig. No. 1</p> <p>Schedule of Openings –</p> <table border="1" data-bbox="240 1055 1310 1361"> <thead> <tr> <th>Sr.No.</th> <th>Symbol</th> <th>Description</th> <th>Size in m</th> <th>Nos.</th> </tr> </thead> <tbody> <tr> <td>1</td> <td>D1</td> <td>T.W. Panelled door or Decorative type door</td> <td>1.2 x 2.1</td> <td>1</td> </tr> <tr> <td>2</td> <td>D2</td> <td>Flush door</td> <td>0.9 x 2.0</td> <td>2</td> </tr> <tr> <td>3</td> <td>D3</td> <td>Flush door or PVC door</td> <td>0.8 x 1.8</td> <td>2</td> </tr> <tr> <td>4</td> <td>O</td> <td>Opening</td> <td>1.0 x 2.0</td> <td>1</td> </tr> <tr> <td>5</td> <td>W1</td> <td>Alluminium Sliding Window</td> <td>1.2 x 1.2</td> <td>6</td> </tr> <tr> <td>6</td> <td>V</td> <td>Louvered window</td> <td>0.8 x 0.8</td> <td>2</td> </tr> </tbody> </table> <p style="text-align: center;"><u>Important Note: Student may take another type of door or window, with different sizes, give credits accordingly.</u></p> <p>Area Statement –</p> <div style="text-align: center;">  </div> <p style="text-align: center;">Block diagram</p>	Sr.No.	Symbol	Description	Size in m	Nos.	1	D1	T.W. Panelled door or Decorative type door	1.2 x 2.1	1	2	D2	Flush door	0.9 x 2.0	2	3	D3	Flush door or PVC door	0.8 x 1.8	2	4	O	Opening	1.0 x 2.0	1	5	W1	Alluminium Sliding Window	1.2 x 1.2	6	6	V	Louvered window	0.8 x 0.8	2	<p>3M</p>
Sr.No.	Symbol	Description	Size in m	Nos.																																	
1	D1	T.W. Panelled door or Decorative type door	1.2 x 2.1	1																																	
2	D2	Flush door	0.9 x 2.0	2																																	
3	D3	Flush door or PVC door	0.8 x 1.8	2																																	
4	O	Opening	1.0 x 2.0	1																																	
5	W1	Alluminium Sliding Window	1.2 x 1.2	6																																	
6	V	Louvered window	0.8 x 0.8	2																																	

	<p>1) Plot area (Assuming all side margin as 3 M) $= (7.49 + 3 + 3) \times (8.69 + 3 + 3)$ $= 13.49 \times 14.69$ $= 198.17 \text{ Sq.M.}$</p> <p>2) Built up Area $= [(7.49 \times 8.69) - (4.03 \times 1.19)]$ $= 60.29 \text{ Sq.M.}$</p> <p>3) F.S.I. allowed 1</p> <p>4) F.S.I. Consumed $= \text{Built up area/ Plot area}$ $= 60.29/ 198.17$ $= 0.304$</p> <p><u>Note: Student may take any other side margin, give credits accordingly.</u></p>	3M																											
(c)	Differentiate between load bearing and framed structure.	6M																											
	<p>Ans;</p> <table border="1" style="width: 100%; border-collapse: collapse;"> <thead> <tr> <th style="width: 10%;">Sr. No.</th> <th style="width: 45%;">Load Bearing Structure</th> <th style="width: 45%;">Framed Structure</th> </tr> </thead> <tbody> <tr> <td>1)</td> <td>Load is transferred to ground or foundation through walls.</td> <td>Load is transferred to ground or foundation through columns.</td> </tr> <tr> <td>2)</td> <td>Walls play an important role as a structural element for taking & transfer of loads.</td> <td>Walls don't transfer load but acts as partition only.</td> </tr> <tr> <td>3)</td> <td>Structure consist slabs, beams and walls.</td> <td>Structure consist slabs, beams, walls and columns.</td> </tr> <tr> <td>4)</td> <td>Continuous wall footing under every wall.</td> <td>Continuous wall footing under every wall.</td> </tr> <tr> <td>5)</td> <td>More space utilised for walls.</td> <td>Less space utilised for walls.</td> </tr> <tr> <td>6)</td> <td>Every floor arrangement shall be same.</td> <td>Scope for changes in arrangement.</td> </tr> <tr> <td>7)</td> <td>(G+2) structure can be constructed at the max.</td> <td>No restriction over no. of floors.</td> </tr> <tr> <td>8)</td> <td>U.C.R. masonry for plinth.</td> <td>U.C.R. masonry may not be used as plinth.</td> </tr> </tbody> </table>	Sr. No.	Load Bearing Structure	Framed Structure	1)	Load is transferred to ground or foundation through walls.	Load is transferred to ground or foundation through columns.	2)	Walls play an important role as a structural element for taking & transfer of loads.	Walls don't transfer load but acts as partition only.	3)	Structure consist slabs, beams and walls.	Structure consist slabs, beams, walls and columns.	4)	Continuous wall footing under every wall.	Continuous wall footing under every wall.	5)	More space utilised for walls.	Less space utilised for walls.	6)	Every floor arrangement shall be same.	Scope for changes in arrangement.	7)	(G+2) structure can be constructed at the max.	No restriction over no. of floors.	8)	U.C.R. masonry for plinth.	U.C.R. masonry may not be used as plinth.	6M (for any six points of difference)
Sr. No.	Load Bearing Structure	Framed Structure																											
1)	Load is transferred to ground or foundation through walls.	Load is transferred to ground or foundation through columns.																											
2)	Walls play an important role as a structural element for taking & transfer of loads.	Walls don't transfer load but acts as partition only.																											
3)	Structure consist slabs, beams and walls.	Structure consist slabs, beams, walls and columns.																											
4)	Continuous wall footing under every wall.	Continuous wall footing under every wall.																											
5)	More space utilised for walls.	Less space utilised for walls.																											
6)	Every floor arrangement shall be same.	Scope for changes in arrangement.																											
7)	(G+2) structure can be constructed at the max.	No restriction over no. of floors.																											
8)	U.C.R. masonry for plinth.	U.C.R. masonry may not be used as plinth.																											
5.	Attempt any TWO of the following:	2 x 6 = 12																											
(a)	Enlist the various documents and drawings required for municipal sanction.	6M																											
	<p>Ans:</p> <p>The various drawings required for municipal sanction are –</p> <ol style="list-style-type: none"> 1) Site Plan : Along with block plan showing plinth outline and area statement 2) Ground floor plan, first floor plan, plans of higher floors. Basement floor plan, terrace plan and car park plan. 3) Elevation 4) Section passing through staircase, W.C., bath etc giving details upto foundation. 5) Schedule of doors, windows and grill work. 6) Schedule giving notes for type of construction. Foundation, R.C.C. work etc. <p>The various documents required for municipal sanction are –</p> <ol style="list-style-type: none"> 1) Notice to execute the proposed work in the standard form. 2) Undertaking from the architect in the standard form. 3) Extract from property register stating the details regarding the owner and land. 4) Plan from city survey office showing boundaries of the plot and adjoining survey numbers. 5) Certificate regarding to area of plot given by a corporation or town planning department. 	1M each (for any six points)																											

(b)	Define following: (i) Floor Area (ii) Super built up Area (iii) Carpet Area	6M															
	<p>Ans:</p> <p>(i) Floor Area – This is the usable covered area of the building at any floor level. Floor area is calculated by deducting area of walls from plinth area.</p> <p>(ii) Super built up Area – When area of common use like staircase, corridors, lift lobbies, lift walls, machine rooms, duct walls, pump rooms, security cabins, panel room, water tanks, servant rooms/toilets, clubhouse, etc. is added proportionally to built up area, it is called as super built up area. This term is mostly used for flats in multi dwelling units like apartments.</p> <p>(iii) Carpet Area – This is the floor area of the usable rooms at any floor OR the area where carpet can be laid.</p>	<p>2M</p> <p>2M</p> <p>2M</p>															
(c)	Suggest various units and their sizes for primary health centre for the structure constructed in a village.	6M															
	<p>Ans:</p> <p>Units required for <u>Primary health centre</u>:</p> <p>a) Entrance or reception - 2.5 m wide b) Doctor's Room – 3 m x 3.6 m c) Examination Room – 3 m x 4 m d) Operation Theatre – 4 m x 5.5 m e) Circulation Space – 3 m wide f) Laboratory – 15 sq. m g) Ward (general/ maternity) – area 8 to 10 sq. m per bed h) Medical Store or Pharmacy – 3 x 4.5 m i) Office – 12 sq. m j) Family Planning Unit – 3 m x 4 m k) Parking - Scooter/ Motorcycle – 3 sq.m./ vehicle, Cycle- 1.2 sq.m./ cycle l) Sanitary block</p> <table border="1" data-bbox="359 1601 1085 1792"> <thead> <tr> <th>Unit</th> <th>Male</th> <th>Female</th> </tr> </thead> <tbody> <tr> <td>W.C.</td> <td>1 in 100</td> <td>1 in 50</td> </tr> <tr> <td>Urinal</td> <td>1 in 50</td> <td>---</td> </tr> <tr> <td>Wash basin</td> <td>1 in 100</td> <td>1 in 100</td> </tr> <tr> <td>Bath</td> <td>2 per ward</td> <td>2 per ward</td> </tr> </tbody> </table> <p><i>*(Note- 1/2 mark for stating six units and 1/2 mark for their respective minimum sizes. i.e. 3 + 3 = 6 marks.)</i></p>	Unit	Male	Female	W.C.	1 in 100	1 in 50	Urinal	1 in 50	---	Wash basin	1 in 100	1 in 100	Bath	2 per ward	2 per ward	<p>6M* (for any six)</p>
Unit	Male	Female															
W.C.	1 in 100	1 in 50															
Urinal	1 in 50	---															
Wash basin	1 in 100	1 in 100															
Bath	2 per ward	2 per ward															

6.	<p>Attempt any <u>ONE</u> of the following:</p> <p>(a) A plan and elevation of pedestal is shown in fig. No. 2. Corner 'A' touches the picture plane and observer is exactly opposite the corner at 5 m distance. Eye level is 1.5 m. Draw two point perspective with 30-60 angles.</p>	<p>1 x 12 = 12</p> <p>12M</p>
<p style="text-align: center;">Fig. 2</p>		
<p>Ans:</p>		
<p><i>*(Note- For drawing neatly picture plane-01 mark, plan-01 mark, elevation-01 mark, two vanishing points-01 mark, construction lines-01 mark, true heights-01 mark, base or body of object-03 marks, top of object-03 marks = total 12)</i></p>		

(b)	Draw a plan and section of single flight of an RCC stair case from following data: (i) Number of Risers – 10 Nos. of 160 mm height. (ii) Number of treads – 9 Nos. of 250 mm width (iii) Width of stair case – 1000 mm (iv) Landing at top is – 1000 x 1000 mm	12M
-----	---	------------

Ans:

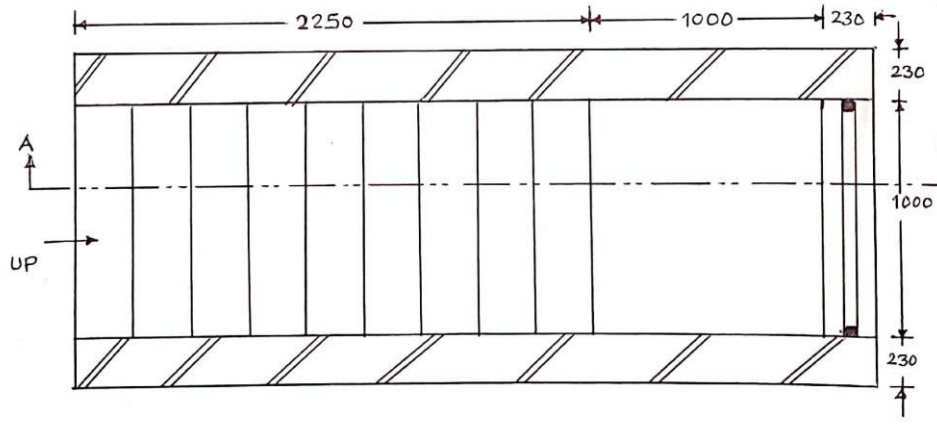
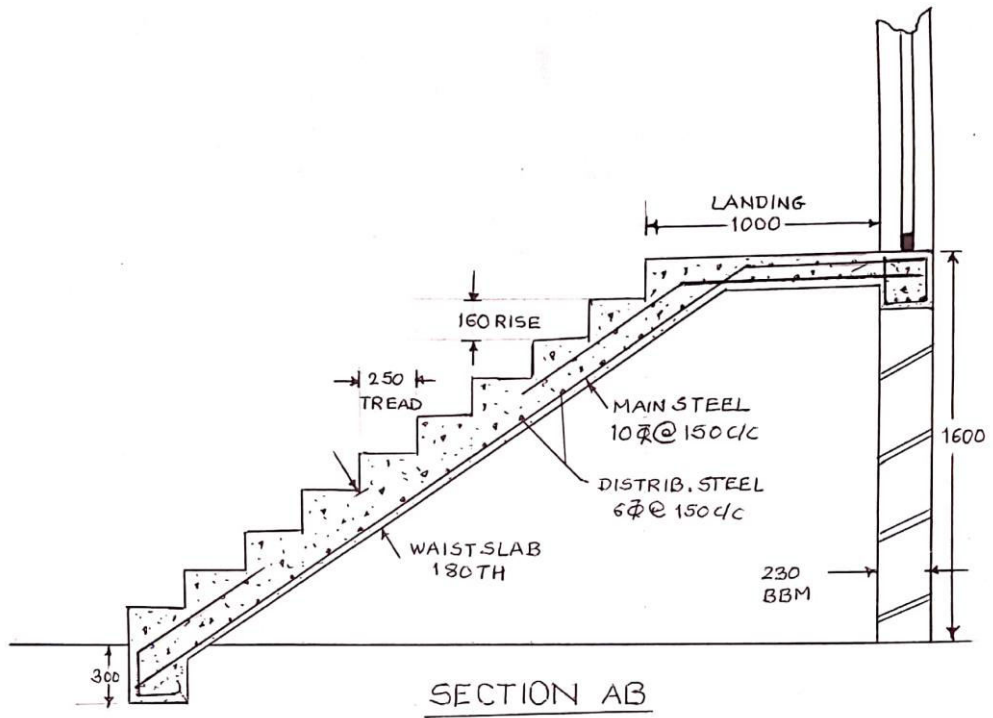

(ALL DIMENSIONS IN MM)
SCALE - 1:25

**(Note- Distribution of 6 marks for plan and section each is as below- 04 marks for arrangement, 01 mark for dimensions, 01 mark for labeling)*

6M*

6M*