

VISION

To ensure that the Diploma level Technical Education constantly matches the latest requirements of technology and industry and includes the all-round personal development of students including social concerns and to become globally competitive, technology led organization.

MISSION

To provide high quality technical and managerial manpower, information and consultancy services to the industry and community to enable the industry and community to face the changing technological and environmental challenges.

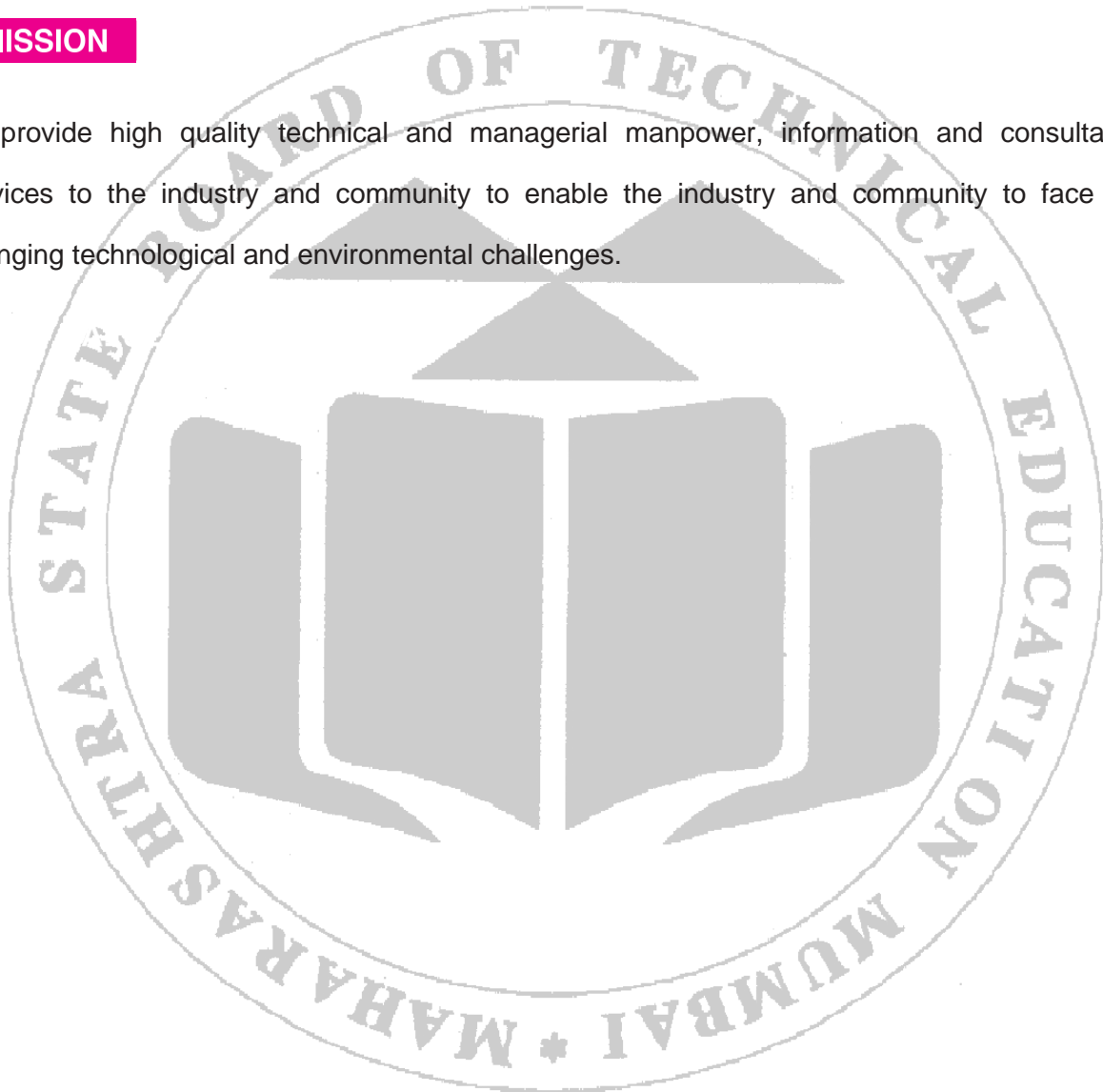

A Laboratory Manual for
Basic Science - Physics
(311305)

Semester-I

Diploma in Engineering and Technology
(All Programme)



Maharashtra State
Board of Technical Education, Mumbai
(Autonomous) (ISO:9001:2015) (ISO/IEC 27001:2013)

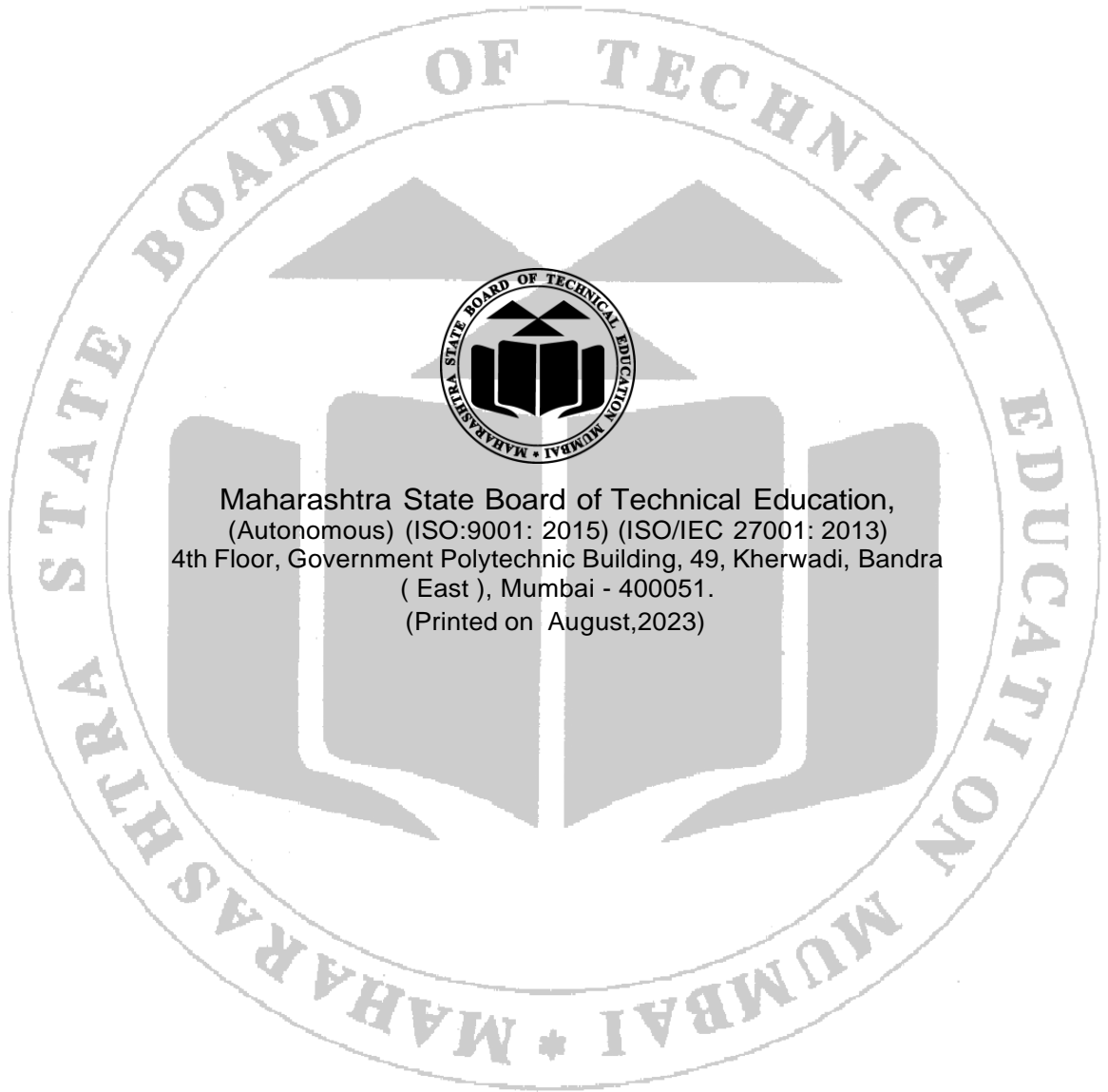

Maharashtra State Board of Technical Education,
(Autonomous) (ISO:9001: 2015) (ISO/IEC 27001: 2013)
4th Floor, Government Polytechnic Building, 49, Kherwadi, Bandra
(East), Mumbai - 400051.
(Printed on August,2023)



Maharashtra State Board of Technical Education Certificate

This is to certify that Mr./Ms.....
Roll No.....of First Semester of Diploma in
.....of
Institute
.....(Code.....)
has completed the term work satisfactorily in course of Basic Science- Physics
(311305) for the academic year 20 ... to 20 As prescribed in the
curriculum.

Place..... Enrollment No.....

Date..... Exam Seat No.....

Course Teacher

Head of the Department

Principal



Preface

The need and importance of fundamental or basic sciences have been established in all walks of technology and everyone has experience that the most important component of basic science are physics and chemistry. The role of physics and chemistry are well accepted in the development of future technology. Therefore it has become essential for every diploma student irrespective of their core discipline to acquire basic knowledge and skills to develop insight not only into its potential and application but also to utilize technology effectively.

Focus in writing this manual has been on developing highly readable experiments that will provide learner with a successful learning experience. Method for developing laboratories begins with identifying concepts that are for particular interest or challenge to students and which would benefit from clarification through laboratory work. From this, experimental learning outcomes are developed and which serve as a key focus point for aspects of given experiment. The pedagogical approach of the laboratory is then chosen to make the most of the topics are trying to be learned. For example, some laboratories benefits from a discovery type approach while others are based taught following a more traditional expository approach.

In particular through this course the students acquire knowledge and skills related to basic physics and chemistry that equip them with the ability to measure, observe keenly, analyze critically, creates the documents for various purpose. The laboratory manual provides detailed guidance to perform the practicals in the right way with necessary resources required to achieve desired outcome.

This lab manual is designed in a way that it is helpful to both the instructors and the students. The manual provides guidelines to help instructors effectively facilitate student-centered activities to be carried out in the lab though practical thus arranging and managing necessary resources, practical outcomes, skills to be achieved through given practical and let students follow the procedures and precautions ensuring the achievement of outcomes and assessing the performance of students.

For students it gives complete guidance regarding minimum theoretical background required to undertake the practical, skills they achieve through the given practical, procedure and necessary precautions to be followed by them. Students can use the acquired knowledge and skills achieved through hands on to solve real-world problems in their professional life. To do this, student must first understand the topic and acquire sufficient background knowledge and implications and limitations of this knowledge.

Programme Outcomes (POs) to be achieved through Practical's

- PO1. Basic and Discipline Specific Knowledge:** Apply knowledge of basic mathematics, science and engineering fundamentals and engineering specialization to solve the engineering problems.
- PO2. Problem Analysis:** Identify and analyse well-defined engineering problems using codified standard methods.
- PO3. Design/Development of Solutions:** Design solutions for well-defined technical problems and assist with the design of systems components or processes to meet specified needs.
- PO4. Engineering Tools, Experimentation and Testing:** Apply modern engineering tools and appropriate technique to conduct standard tests and measurements.
- PO5. Engineering practices for Society, Sustainability and Environment:** Apply appropriate technology in context of society, sustainability, environment and ethical practices.
- PO6. Project Management:** Use engineering management principles individually, as a team member or a leader to manage projects and effectively communicate about well-defined engineering activities.
- PO7. Life-Long learning:** Ability to analyse individual needs and engage in updating in the context of technological changes.

Practical- Course Outcome matrix

Course Outcomes (COs)				
a. Use basic instruments to measure the physical quantities in various engineering situations. b. Apply the basic principles of electromagnetics to solve given engineering problems. c. Apply basic principles of thermometry and fibre optics to solve engineering problems.				
Sr. No.	Title of the Practical	CO1 a.	CO2 b.	CO3 c.
1.	Measurements of dimensions of given object by Vernier caliper.	√		
2.	Measurements of dimensions of given objects by micrometer screw gauge.	√		
3.	Determination of resistance by Ohm's law.		√	
4.	Determination of specific resistance of given wire.		√	
5.	Determination of equivalent resistance in series connection of resistors.		√	
6.	Determination of equivalent resistance in parallel connection of resistors.		√	
7.	Determination of neutral points by magnetic compass.		√	
8.	Determination of static and dynamic resistance of given P N junction diode.		√	
9.	Determination of forbidden energy band gap in semiconductors.		√	
10.	Determination of Joule's mechanical equivalent of heat by Joule's law.		√	
11.	Determination of pressure-volume relation using Boyle's law.			√
12.	Determination of the rate of heat loss due to convection by Newton's law of cooling.			√
13.	Determination of Coefficient of thermal conductivity.			√
14.	Determination of the refractive index of glass slab.			√
15.	Determination of the Numerical Aperture (NA) of a given step index optical fiber			√

List of relevant skills

1. Intellectual Skills
2. Psychomotor Skills
3. Affective Domain Skills
4. Teamwork
5. Prioritisation
6. Communication
7. Interpersonal skills
8. Research skill

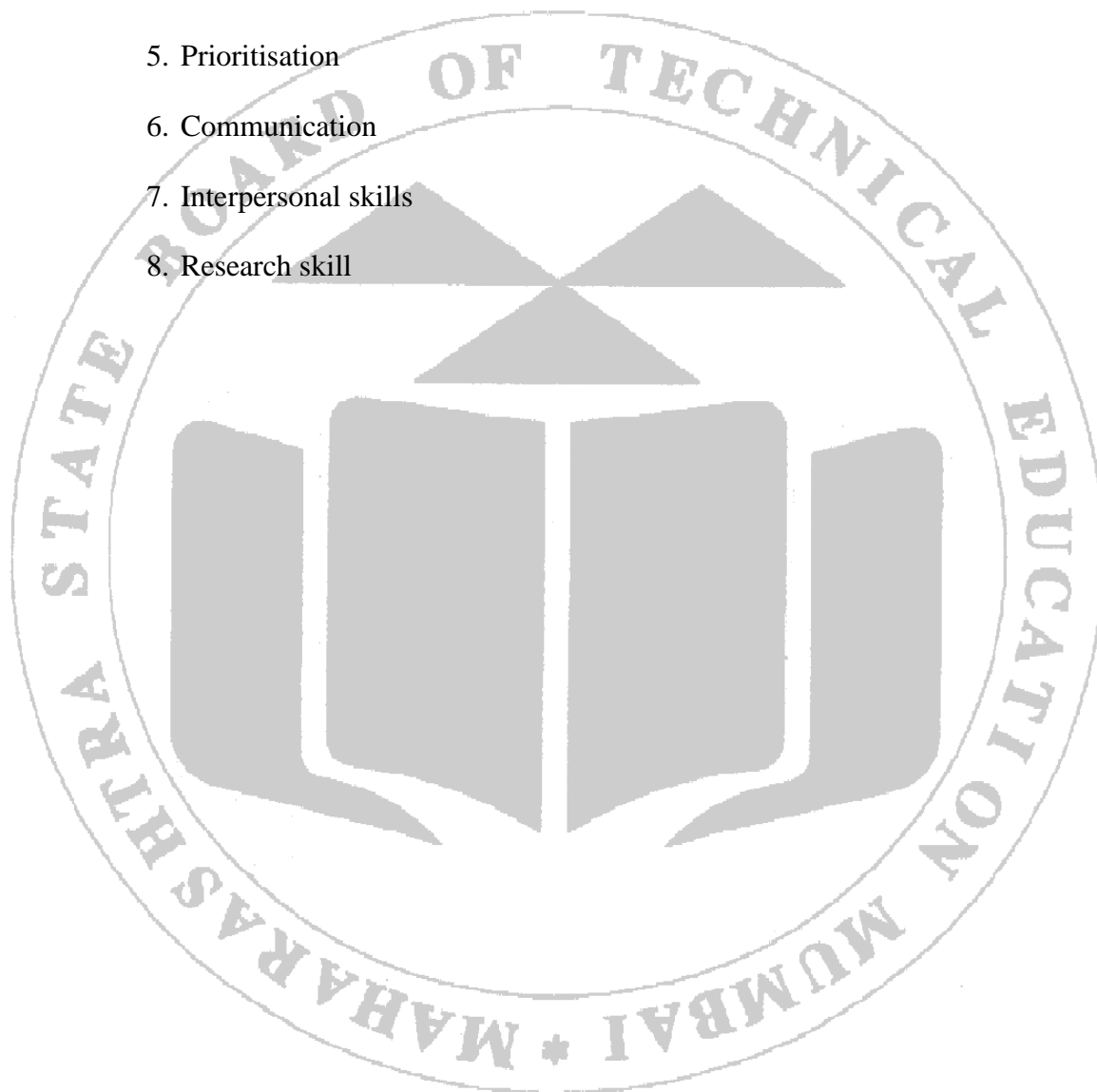

Brief Guidelines to Teachers

1. For incidental writing on the day of each practical session every student should maintain a dated log book for the whole semester, apart from this laboratory manual which s/he has to submit for assessment to the teacher in the next practical session.
2. There will be two sheets of blank pages after every practical for the student to report other matters which is not mentioned in the printed practicals.
3. For difficult practicals if required, teacher could provide the demonstration of the practical emphasizing of the skills which the student should achieve.
4. Teachers should give opportunity to students for hands-on after the demonstration.
5. Assess the skill achievement of the students and COs of each unit.

Instructions to Students

1. Students should listen carefully the procedure of practical, method of assessment, tentative plan of work in laboratory and total amount of work to be completed in the whole semester.
2. Students should be well prepared while submitting the practical work and submit it for assessment to the teacher in the next practical session, which will develop continuity in the studies.

Content Page

List of Practical's and Progressive Assessment Sheet

Sr. No.	Practical outcomes	Page No.	Date of performance	Date of Submission	Assessment marks(25)	Dated sign. of teacher
1.	*Measurements of dimensions of given object by Vernier caliper.	1				
2.	*Measurements of dimensions of given objects by micrometer screw gauge.	8				
3.	*Determination of resistance by Ohm's law.	15				
4.	Determination of specific resistance of given wire.	23				
5.	*Determination of equivalent resistance in series connection of resistors.	31				
6.	Determination of equivalent resistance in parallel connection of resistors.	39				
7.	*Determination of neutral points by magnetic compass.	47				
8.	*Determination of static and dynamic resistance of given P N junction diode.	54				
9.	Determination of forbidden energy band gap in semiconductors.	63				
10.	*Determination of Joule's mechanical equivalent of heat by Joule's law.	71				
11.	Determination of pressure-volume relation using Boyle's law.	79				
12.	Determination of the rate of heat loss due to convection by Newton's law of cooling.	86				
13.	Determination of Coefficient of thermal conductivity.	93				
14.	*Determination of the refractive index of glass slab.	99				
15.	Determination of the Numerical Aperture (NA) of a given step index optical fiber	105				
					Marks out of 25	

Note : Out of above suggestive LLOs -

- '*' Marked Practical's (LLOs) are mandatory.
- Minimum 80% of above list of lab experiment are to be performed.
- Judicial mix of LLOs are to be performed to achieve desired outcomes.

Practical No. 01: Measurements of dimensions of given object by Vernier caliper.**I Practical Significance**

In industries measurement of inner diameter, outer diameter, height and depth of objects with utmost accuracy and precision is a prime requirement. For the measurement of the objects having dimensions less than 1mm or to measure the dimensions of curved surfaces, normal scales cannot be used. Such kind of measurements are possible using measuring instruments like Vernier caliper, micrometer screw gauge etc. In this lab experiment we use Vernier caliper to measure the dimensions of objects in centimeters up to two significant figures.

II Industry/ Employer Expected Outcome

Apply principles of physics and chemistry to solve broad based relevant engineering problems.

III Course Level Learning Outcome

Use basic instruments to measure the physical quantities in various engineering situations

IV Laboratory Learning Outcome(s)

- Use Vernier caliper to: Measure dimensions of given objects. Measure the dimensions of objects of known dimensions.
- Estimate the errors in measurement.

V Relevant Affective domain related Outcomes

- a. Handle tools and equipment carefully.
- b. Select proper instrument.

VI Relevant Theoretical Background

Vernier Caliper is an instrument used to measure dimensions such as inner diameter, outer diameter, height, depth, thickness of an object. Least count (L.C) of instrument is the smallest measurement that can be taken by using an instrument. Range of Vernier caliper is the maximum measurement that can be taken by using the instrument. There are two separate scales on Vernier caliper namely Main Scale and Vernier scale. Least count of Vernier Caliper is given by

Least count = Smallest reading on main scale (m) / Total Number of divisions on Vernier scale (n)

Zero error occurs in an instrument due to non coincidence of zero of main scale with zero of vernier scale when the jaws are closed.

VII Circuit Diagram / Experimental Set Up/ Work Situation

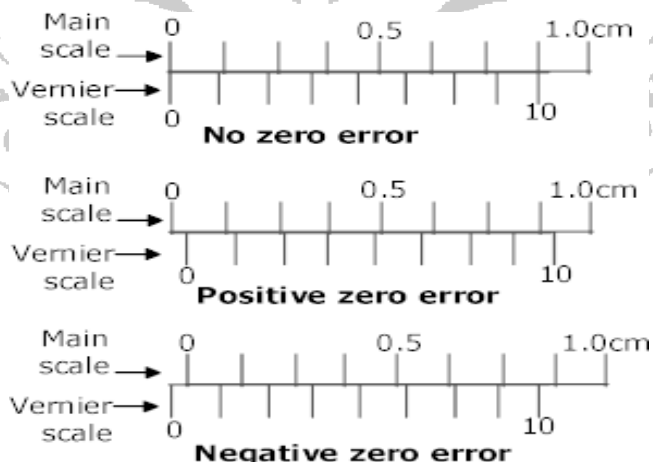
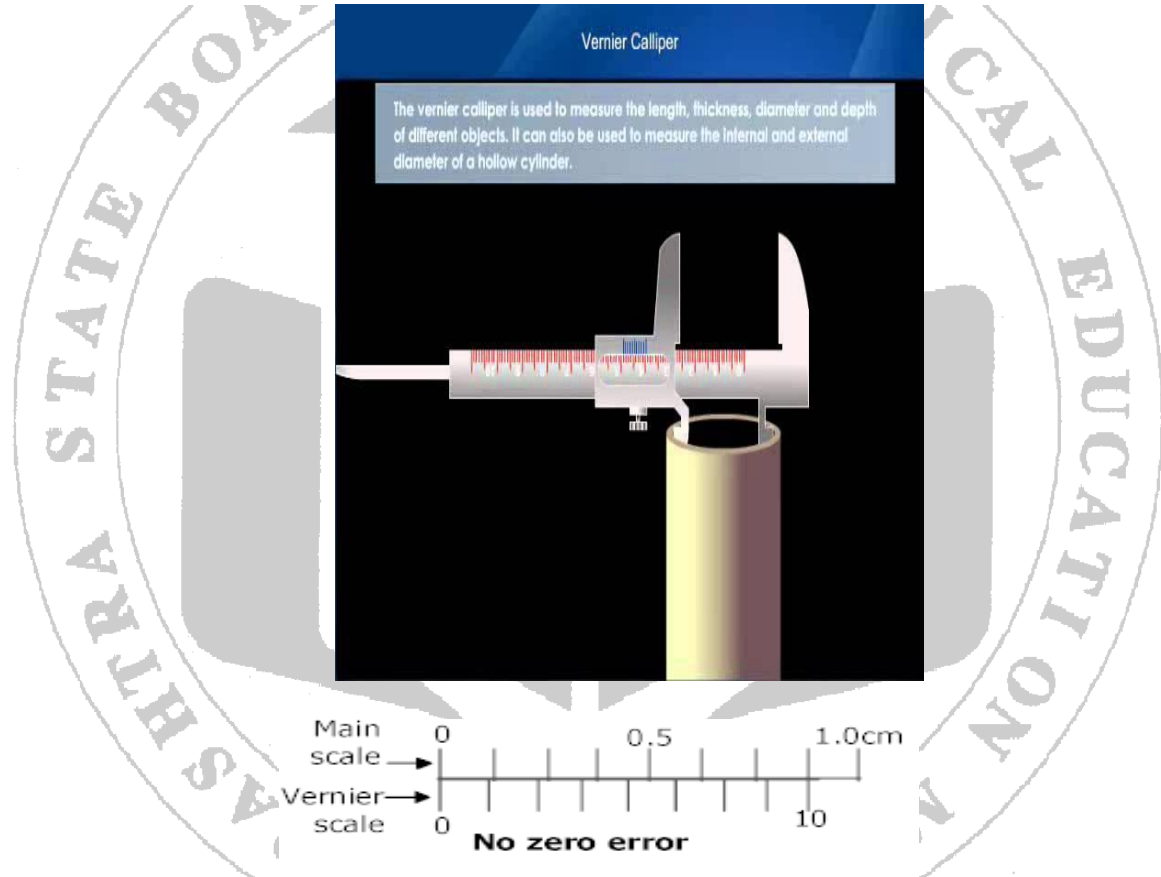
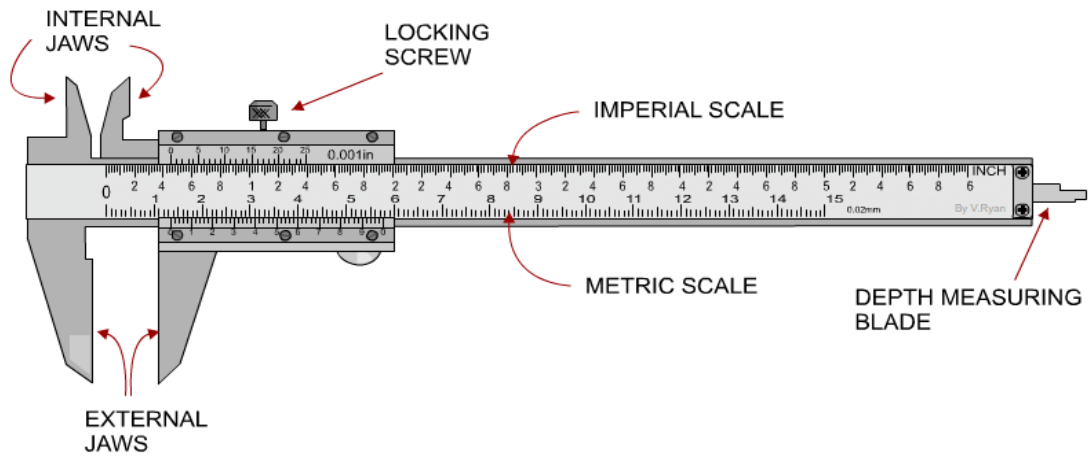

Figure 2

VIII Resources required

Sr. No.	Instrument /Object	Specification	Quantity
1.	Vernier Caliper	L.C.=0.002cm Range=0-15cm	1 No.
2.	Hollow Cylindrical Pipe	Any dimensions	1 No.
3.	Rectangular wooden block	Any dimensions	1 No.
4.	Hollow pipe	16 gauge thickness	1 No.

IX Precautions

1. The jaws of Vernier caliper should not be pressed hard while taking the readings.
2. The division of Vernier scale exactly coinciding with the main scale should be noted down accurately.
3. Parallax should be removed.

X Procedure

1. Identify each part of the instrument.
2. Find the least count of given Vernier calipers using the formula given in the theoretical background.
3. Find the zero error (z) of given Vernier caliper as given in Fig.02.
4. Hold the given object in the appropriate jaws depending upon the parameter to be measured.
5. Observe the zero of the Vernier scale and take main scale reading (MSR)
6. Check the division of Vernier scale coinciding with the main scale and note it down as (VSD).
7. Find the vernier scale reading; $VSR = (VSD \times L.C.)$
8. Calculate the total reading using the formula: Total reading (TR)= MSR+VSR.
9. Calculate the corrected reading $CR = TR \pm z$

XI Observations

1. Value of smallest division on main scale= $m =$ cm.
2. Total no of divisions on Vernier scale = $n =$
3. Least count (LC) of Vernier caliper= $m/n =$cm.
4. Zero error = (coinciding Vernier division with main scale x LC) =.....cm.
5. Zero error correction (z) = +..... cm or -..... cm or No error.

Observation Table

Object	Dimension	MSR cm	Coinciding VSD	VSR = VSD X LC cm	TR= MS R + VSR cm	CR = TR ± (z) cm	Average cm
Hollow cylinder	Inner Diameter (D1)	1					
		2					
		3					
Hollow cylinder	Outer Diameter (D2)	1					
		2					
		3					
Hollow cylinder	Height (h)	1					
		2					
		3					

XII Results

- a. Average inner diameter of hollow cylinder $D_1 = \dots\dots\dots$ cm
- b. Average outer diameter of hollow cylinder = $D_2 = \dots\dots\dots$ cm
- c. Average height Hollow cylinder = $h = \dots\dots\dots$ cm

XIII Interpretation of results



Using digital vernier caliper we verify the

- Inner diameter of hollow cylinder $D_1 = \dots\dots\dots$ cm
- Outer diameter of hollow cylinder = $D_2 = \dots\dots\dots$ cm
- Height of Hollow cylinder = $h = \dots\dots\dots$ cm

XIV Conclusions and Recommendations

.....

XV Practical Related Questions

Note: Below given are few sample questions for reference. Teachers must design more such questions so as to ensure the achievement of identified CO.

1. Give the value of smallest division on main scale and the total no. of divisions on Vernier scale of the instrument used in experiment.
2. Write the range of the Vernier caliper used in the experiment. Write two application of vernier caliper.
3. Determine the least count (L.C.) of Vernier caliper if smallest division on main scale is 1mm and the number of divisions on Vernier scale is 20.
4. A student has used a Vernier caliper with LC 0.01 cm, to measure the length of his pencil. He found that the main scale showed a reading of 7.3 cm and Vernier scale coincides with 5th position to the main scale.
5. Give the correct measurement of the length of the pencil neglecting zero error

[Space to Write Answers]

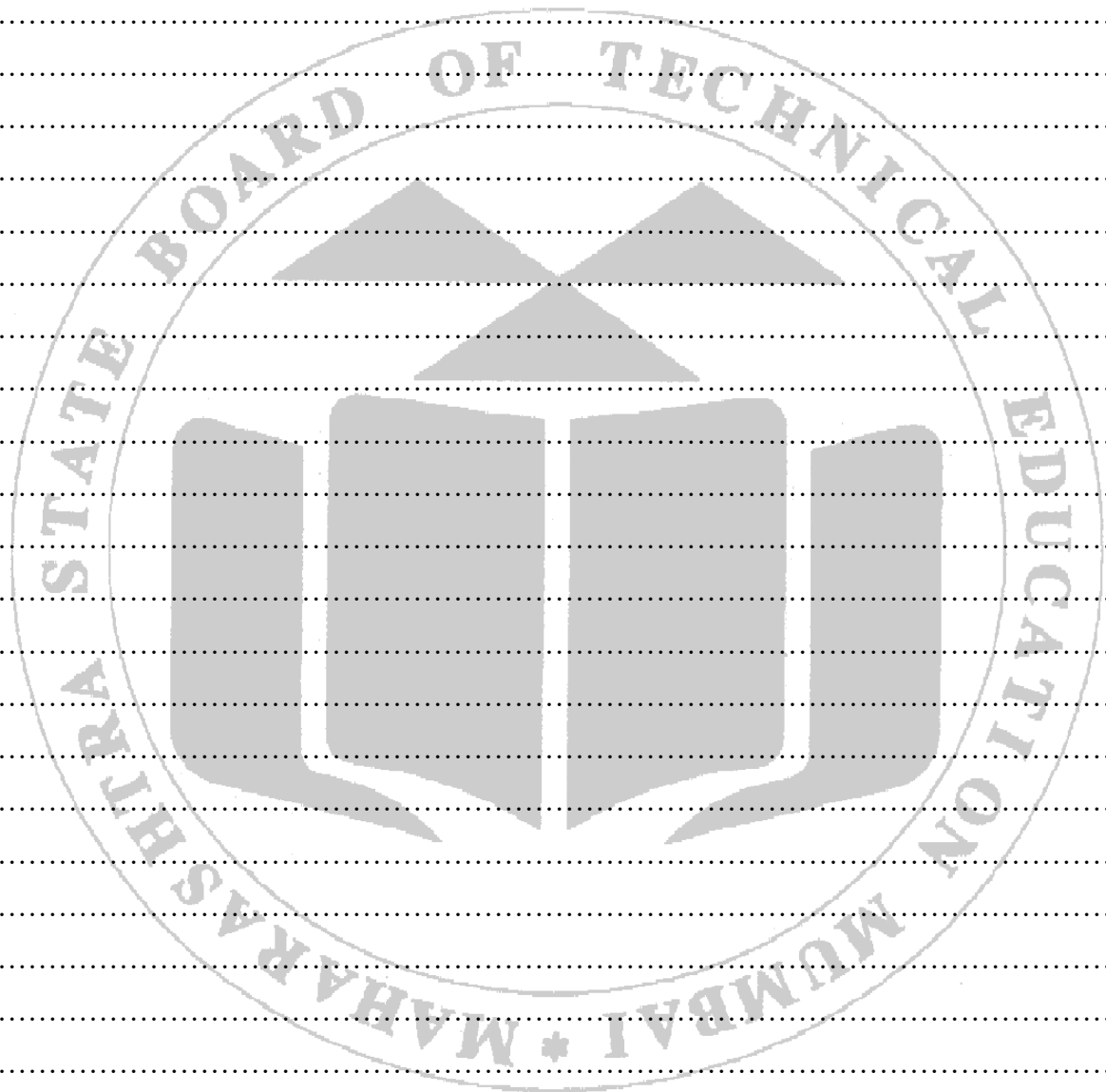

XVI References / Suggestions for further Reading

- <https://amrita.olabs.edu.in/?sub=1&brch=5&sim=16&cnt=4>
- <https://youtu.be/eJpdb7UaOug>
- https://iwant2study.org/lookangejss/01_measurement/ejss_model_AAPTvernierCaliper/AAPTVernierCaliper_Simulation.xhtml

XVII Assessment Scheme

Performance indicators		Weightage
Process related: 15 Marks		60%
1.	Handling of the instrument	10
2.	Arrangement of Practical set up	10
3.	Observation & Observation Table	10
4.	Calculation	10
5.	Result	10
6.	Team Spirit	10
Product related: 10 Marks		40%
1.	Timely Submission	10
2.	Interpretation of result	10
3.	Conclusions & Recommendations	10
4.	Practical related questions	10

List of Student Team Members.

-
-
-
-

Marks Obtained			Dated Signature of Faculty
Process Related (15)	Product Related (10)	Total (25)	

Practical No. 02: Measurements of dimensions of given objects by micrometer screw gauge.

I Practical Significance

In industries, many times there is a need to measure the thickness, diameter of objects with utmost precision. Scale is used for the measurement of parameters like length, breadth and height of plane surfaces. Micrometer screw gauge is used to measure dimensions of objects less than 0.1 mm, that cannot be measured by other instruments.

II Industry/ Employer Expected Outcome

Apply principles of physics and chemistry to solve broad based relevant engineering problems.

III Course Level Learning Outcome

Use basic instruments to measure the physical quantities in various engineering situations.

IV Laboratory Learning Outcome(s)

Use Micrometer Screw gauge to: Measure dimensions of given objects. Measure the dimensions of objects of known dimensions. Estimate the errors in measurement.

V Relevant Affective domain related Outcomes

- a. Handling tools carefully.
- b. Select proper instrument.

VI Relevant Theoretical Background

Micrometer screw gauge: It was invented by William Gascoigne. It is an instrument which consists of two scales i.e. main scale and circular scale.

1. **Pitch (p):** It is the distance between two consecutive threads of the screw. The screw moves forward or backward through a distance equal to its pitch when one complete rotation is given to it. Therefore to find out pitch of the screw, give one rotation to it and find out through how much distance it moves.

2. Least count (LC)

Least count is the smallest measurement that can be done accurately by any measuring instrument. Thus least count indicates the degree of accuracy of measurement by that instrument.

3. Least count (LC) of micrometer screw gauge

It is ratio of pitch of the screw (p) to the total no of division on circular scale (n).

$$L.C. = \frac{\text{Pitch of the Screw (p)}}{\text{Number of division on the circular scale (n)}} \dots \dots \dots (1)$$

4. Zero error

The zero error is the error caused by non coincidence of zero of circular scale with axial line on main scale when the jaws are closed. Students should refer following diagrams to determine zero error in the instrument used in this lab experiment.

5. Zero error correction (z)

Zero error correction (z) is obtained by adding or subtracting zero error.

When zero error obtained is positive zero error correction (z) is negative.

When zero error obtained is negative zero error correction (z) is positive.

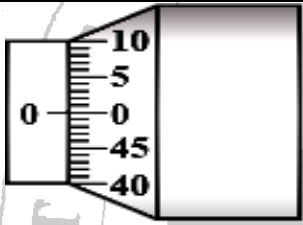
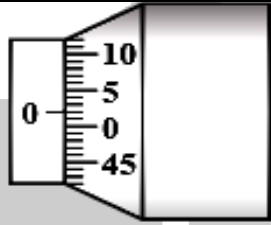
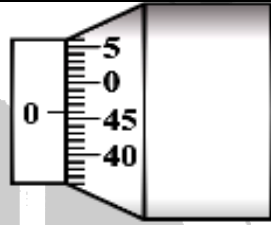
 <p style="text-align: center;">(a) No zero error</p>	 <p style="text-align: center;">(b) Positive zero error</p>	 <p style="text-align: center;">(c) Negative zero error</p>
<p>Zero error = No error</p>	<p>Zero error = Positive error Zero error = + (3 × LC) Zero correction (z) = - (3 × L.C.)</p>	<p>Zero error = Negative error Zero error = - [(n - 99) × LC] Zero correction (z) = + [(n - 99) × L.C.</p>

6. Total reading (TR) of measurement

- (i) Total reading (TR) is an addition of main scale reading (MSR) and circular scale reading (CSR).
- (ii) Circular scale reading is the multiplication of circular scale division (CSD) and least count (LC)

7. Corrected reading (CR) of measurement

Corrected reading is the addition of total reading (TR) and the zero error correction (z).

$$TR = MSR + CSR$$

$$TR = MSR + (CSD \times LC)$$

$$\text{and } CR = TR \pm \text{Zero error correction (z)}$$

VII Experimental Set Up

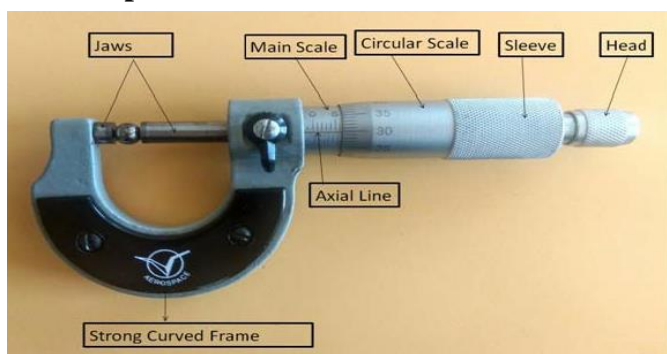

VIII Resources required

Sr. No.	Particulars	Specification	Quantity
1	Micrometer Screw Gauge	L.C=0.001cm, Range=0 to 2.5cm	01 for each student
2	Metallic Sphere	Unknown Diameter	01
3	Plate	Unknown thickness	01
4	Thin metal wire	Diameter-16/18/20 gauge	01

IX Precautions

1. Only screw head should be rotated and the sleeve should not be rotated to avoid excess pressure.
2. The screw should be always rotated in one direction to avoid backlash error.

X Procedure

1. Hold the micrometer screw gauge carefully.
2. Identify the main scale and circular scale.
3. Determine the pitch of the screw.
4. Count the number of divisions on circular scale.
5. Calculate L.C. of micrometer screw gauge using equation (1).
6. Identify coinciding division from axial line and calculate zero error (refer zero error diagram).
7. Hold the object in the jaws of micrometer screw gauge. (The jaws should perfectly touch the surface of object).
8. Note main scale reading (MSR) with respect to edge of the rotating drum.
9. Note the circular scale division (CSD) coinciding with the axial line.
10. Determine the circular scale reading (CSR) using the formula $CSR = \text{coinciding circular division(CSD)} \times L.C.$
11. Calculate Total Reading $T.R. = M.S.R. + C.S.R.$
12. Calculate zero error correction z (refer error diagrams)
13. Calculate corrected Reading.

$$\text{Corrected Reading} = T.R. \pm \text{Zero error correction } (z)$$

XI Observations and Calculations

1. Pitch of the screw= Distance travelled by the screw on main scale I in one rotation=
 $p = \dots\dots\dots \text{cm}.$
2. Total number of divisions on circular scale = $n = \dots\dots\dots$
3. Least count of micrometer screw gauge = $pin = \dots\dots\dots \text{cm}$
4. Zero error= $\dots\dots\dots \text{cm}$
5. Zero error correction, $z = \text{Coinciding circular division with axial line (C.S.D.)} \times$
 $\text{L.C.} = + \dots\dots\dots \text{cm} / \text{cm} / \text{No zero error}$

Table 1: Measurement of diameter and thickness

Object	Dimension	MSR cm	CSD	CSR = (CSD X LC) cm	TR= (MS R+ CSR) Cm	CR = TR± (z) cm	Average reading cm
Metallic Sphere	Diameter (Ds)	1					
		2					
		3					
Block	Thickness (t)	1					
		2					
		3					
Thin metallic wire	Diameter (Dw)	1					
		2					
		3					

XII Results

1. Average diameter of metallic sphere = $D_s = \dots\dots\dots \text{cm}.$
2. Average thickness of block= $t = \dots\dots\dots \text{cm}$
3. Average diameter of thin metallic wire = $D_w = \dots\dots\dots \text{cm}$

XIII Interpretation of results



Using Digital micrometer screw gauge verify the above result

1. Average diameter of metallic sphere = $D_s = \dots\dots\dots \text{cm}.$
2. Average thickness of block= $t = \dots\dots\dots \text{cm}.$

3. Average diameter of thin metallic wire = $D_w =$ cm

XIV Conclusions and Recommendations

.....
.....

XV Practical Related Questions

Note: Below given are few sample questions for reference. Teachers must design more such questions so as to ensure the achievement of identified CO.

1. Are micrometers used in telescopes or microscopes?
2. State the main types of screw gauges.
3. State the range of given micrometer screw gauge used in experiment.
4. The circular scale of a screw gauge contains 100 divisions and its pitch is 1 mm.
5. Give the least count of the screw gauge.
6. In ten rotations of the screw, distance travelled on main scale is 20 mm. If number of divisions on circular scale are 50. Find L.C. of micrometer screw gauge.

[Space to Write Answers]

.....
.....
.....
.....
.....
.....
.....
.....
.....
.....
.....
.....
.....
.....
.....
.....
.....
.....
.....
.....
.....

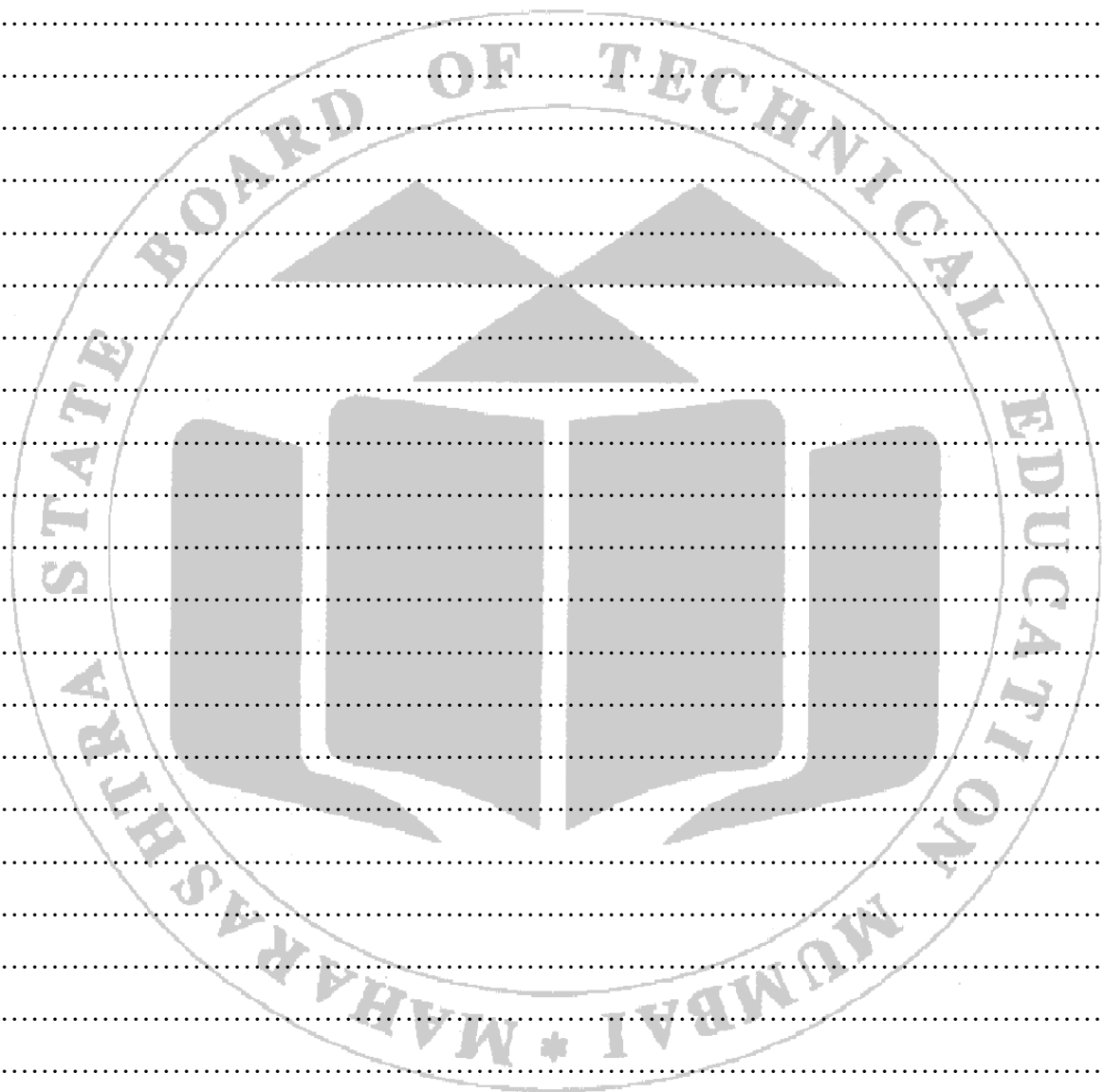

XVI References / Suggestions for further Readings

- a. <https://maheshkurmi.github.io/experiments/micrometer.html>
 b. <https://amrita.olabs.edu.in/?sub=1&brch=5&sim=156&cnt=4>
 c. <https://www.stefanelli.eng.br/en/simulator-virtual-micrometer-hundredths-millimeter/>

XVII Assessment Scheme

Performance indicators		Weightage
Process related: 15 Marks		60%
1.	Handling of the instrument	10
2.	Arrangement of Practical set up	10
3.	Observation & Observation Table	10
4.	Calculation	10
5.	Result	10
6.	Team Spirit	10
Product related: 10 Marks		40%
1.	Timely Submission	10
2.	Interpretation of result	10
3.	Conclusions & Recommendations	10
4.	Practical related questions	10

List of Student Team Members.

1.
 2.
 3.
 4.

Marks Obtained			Dated Signature of Faculty
Process Related (15)	Product Related (10)	Total (25)	

Practical No. 3 Determination of resistance by Ohm's law.

I Practical Significance

The precise measurement of electric current, voltage, resistance is required in electrical, mechanical industries. It is imperative to have a method by which we can measure all these electrical parameters. Resistance, current and voltage can all be determined by way of the formula which is needed for designing circuits. Ohm's law is used to find out the desired amount of resistance, voltage and / or current levels to make sure that we are able to design circuits. It is applicable to decide the ratings of home and electrical appliances.

II Industry/ Employer Expected Outcome

Apply principles of physics and chemistry to solve broad based relevant engineering problems.

III Course Level Learning Outcome

Apply the basic principles of electromagnetics to solve given engineering problems.

IV Laboratory Learning Outcome(s)

Apply Ohm's law to solve circuit problems..

V Relevant Affective domain related Outcomes

1. Circuit connections Skills.
2. Measurement Skills.

VI Relevant Theoretical Background

Ammeter is used to measure electric current (I) & voltmeter is used to measure potential difference (voltage) (V).

Ohm's law: It states that "provided the physical state of the conductor (length, area, temperature) remaining the same in the closed circuit, the current (I) flowing through the conductor is directly proportional to the potential difference (voltage) (V) between the two points of the conductor".

$$I \propto V$$

$$V=IR$$

$$R=V/I$$

Where R is the resistance of the conductor.

Nichrome wire: Nichrome is the form of resistance heating alloy. A common Nichrome alloy is 80% nickel and 20% chromium, by mass, but there are many other combinations of metals for various applications. Nichrome is silvery-grey in colour, is corrosion-resistant, and has a high melting point of about 1,400 °C (2,550 °F). Nichrome is widely used in electric heating elements such as in hair dryers and heat guns.

Eureka wire: Constantan or Eureka is a Cupronic alloy usually consisting of few metals and chemicals melted together at a very high temperature and pressure to form alloy. Its main feature is its resistivity which is constant over a wide range of temperature. Due to its powerful property of constant resistivity up to a wide range of temperature it is widely used in Electrical instruments like current controlling

devices, Rheostats, Potentiometers, Thermocouples, Compensating Cables, Load Banks, Electrical speed controllers, Switches, Electric Meters and so on.

VII Circuit Diagram / Experimental set up / Work Situation.

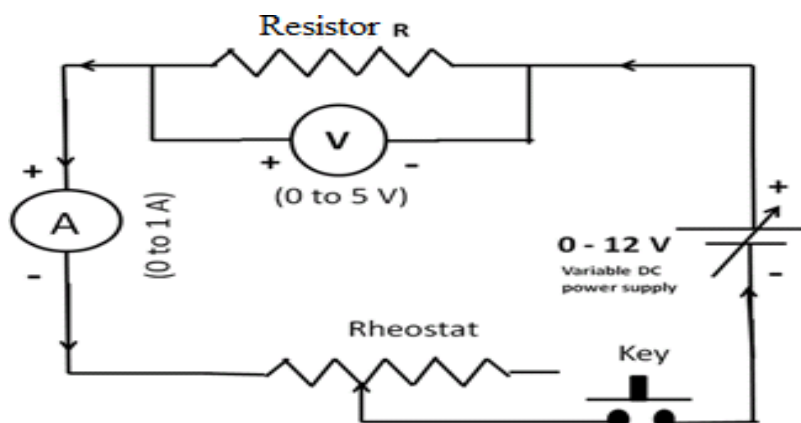

Fig. 01

VIII Resources required

Sr. No.	Instrument	Specification	Quantity
1	Power supply	Range- 0 to 12V Range-500 mA	01
2	Ammeter	Range- 0 to 5A	01
3	Voltmeter	Range- 0 to 10V	01
4	Rheostat	Range- 0 to 500 Ω	01
5	Key		01
6	Resistance Wire	Nichrome/Eureka	01
7	Multimeter	Range-0 to 20 M Ω Range-0 to 5 A Range-0 to 10 V	01
8	Key		01

IX Precautions

1. All electrical Connections should be neat and tight.
2. The pointer of ammeter/voltmeter should coincide with zero mark.
3. Check the power supply before connection.
4. Check connection with the help of teacher.
5. Connect Ammeter in series.
6. Connect Voltmeter in parallel.
7. The key should be inserted only while taking readings.

X Procedure

Part I

1. Make connection as per circuit diagram (Fig. 01)
2. Note the LC of Ammeter and range
3. Note the LC of Voltmeter and range.
4. Check connection with the help of teacher.
5. Switch on power supply.
6. Close key in circuit.
7. Keep the position of rheostat at maximum resistance.
8. Ensure that the position of ammeter and voltmeter pointer at minimum.
9. Note the reading of ammeter and voltmeter
10. Change the position of sliding arm/ variable arm of rheostat gradually.
11. Note the corresponding change reading in ammeter and voltmeter.
12. Calculate the resistance of wire using the formula: $R = \frac{V}{I}$
13. Repeat the step from 10 to 12 five times
14. Plot the graph with electric current (I) along X-axis and voltage (V) along Y-axis.
15. Find slope of the graph. Determine the resistance by graph.

Part II

1. Make connection as per circuit diagram.
2. Connect multimeter instead of ammeter.
3. Connect multimeter instead of voltmeter.
4. Repeat the steps 4 to 16 given in Part I of procedure.

XI Observations and Calculations

1. Using Voltmeter & ammeter Least count of ammeter = -
2. Range of ammeter =-----
3. Least count of voltmeter = -
4. Range of voltmeter =-----

Table 1 (Using ammeter/ voltmeter)

Using Multimeter for the measurement Range of multimeter as ammeter = -
 Range of multimeter as voltmeter=.....

Range of multimeter as ohm meter =.....

Sr. No.	Electric current I (Ampere)	Potential difference V (volt)	Resistance R (ohm) = V/I	Mean Resistance R (ohm)
1				
2				
3				
4				
5				

Table 2 (Using multimeter)

Sr. No.	Electric current I (Ampere)	Potential difference V (volt)	Resistance R (ohm) = V/I	Mean Resistance R (ohm)
1				
2				
3				
4				
5				

XII Results

Resistance of given wire	From observation R Ω	From graph R Ω
By using voltmeter and ammeter		
By using multimeter		

XIII Interpretation of results

.....

.....

.....

XIV Conclusions and Recommendations

.....

.....

.....

XV Practical Related Questions

Note: Below given are few sample questions for reference. Teachers must design more such questions so as to ensure the achievement of identified CO.

1. State the function of rheostat in this lab experiment.
2. A potential difference of 15V appears across the ends of a resistor when 5A of current flows through it. Find resistance of the resistor?
3. If the voltage across a fixed value of resistance is increased five times, what will be the variation in current? Does the resistance depend on the temperature?
4. Calculate the voltage if a resistance of 25 Ω produces a current of 250 amperes.
5. State Ohm's Law.

[Space to Write Answers]

.....

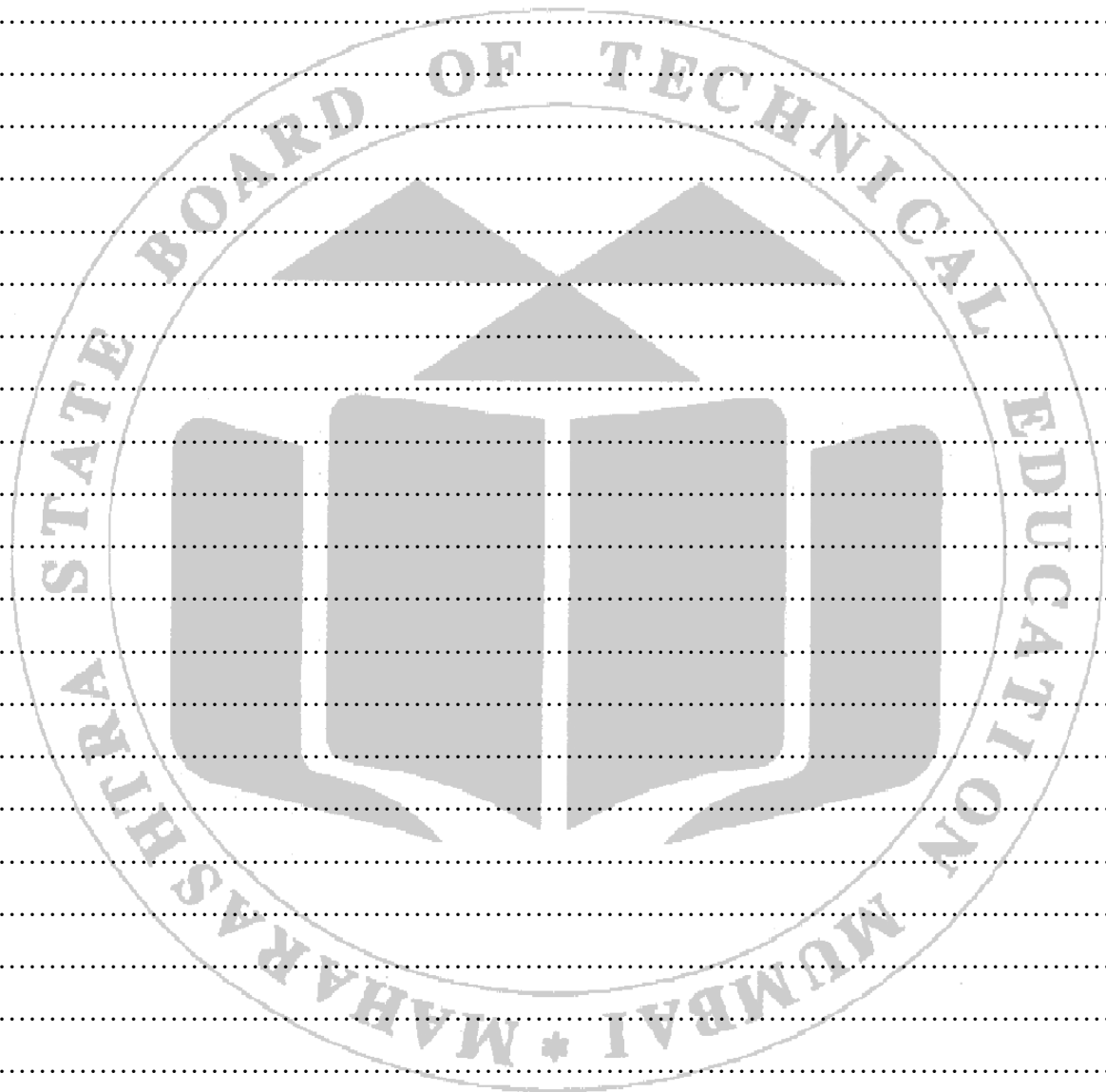

XVI References / Suggestions for further Reading

- a. https://phet.colorado.edu/sims/html/ohms-law/latest/ohms-law_en.html

- b. https://youtu.be/8yHia3gE_LY
 c. https://www.youtube.com/watch?v=E_DsqQARbFg

XVII Assessment Scheme

Performance indicators		Weightage
Process related: 15 Marks		60%
1.	Handling of the instrument	10
2.	Arrangement of Practical set up	10
3.	Observation & Observation Table	10
4.	Calculation	10
5.	Result	10
6.	Team Spirit	10
Product related: 10 Marks		40%
1.	Timely Submission	10
2.	Interpretation of result	10
3.	Conclusions & Recommendations	10
4.	Practical related questions	10

List of Student Team Members.

1.
2.
3.
4.

Process Related (15)	Marks Obtained		Dated Signature of Faculty
	Product Related (10)	Total (25)	



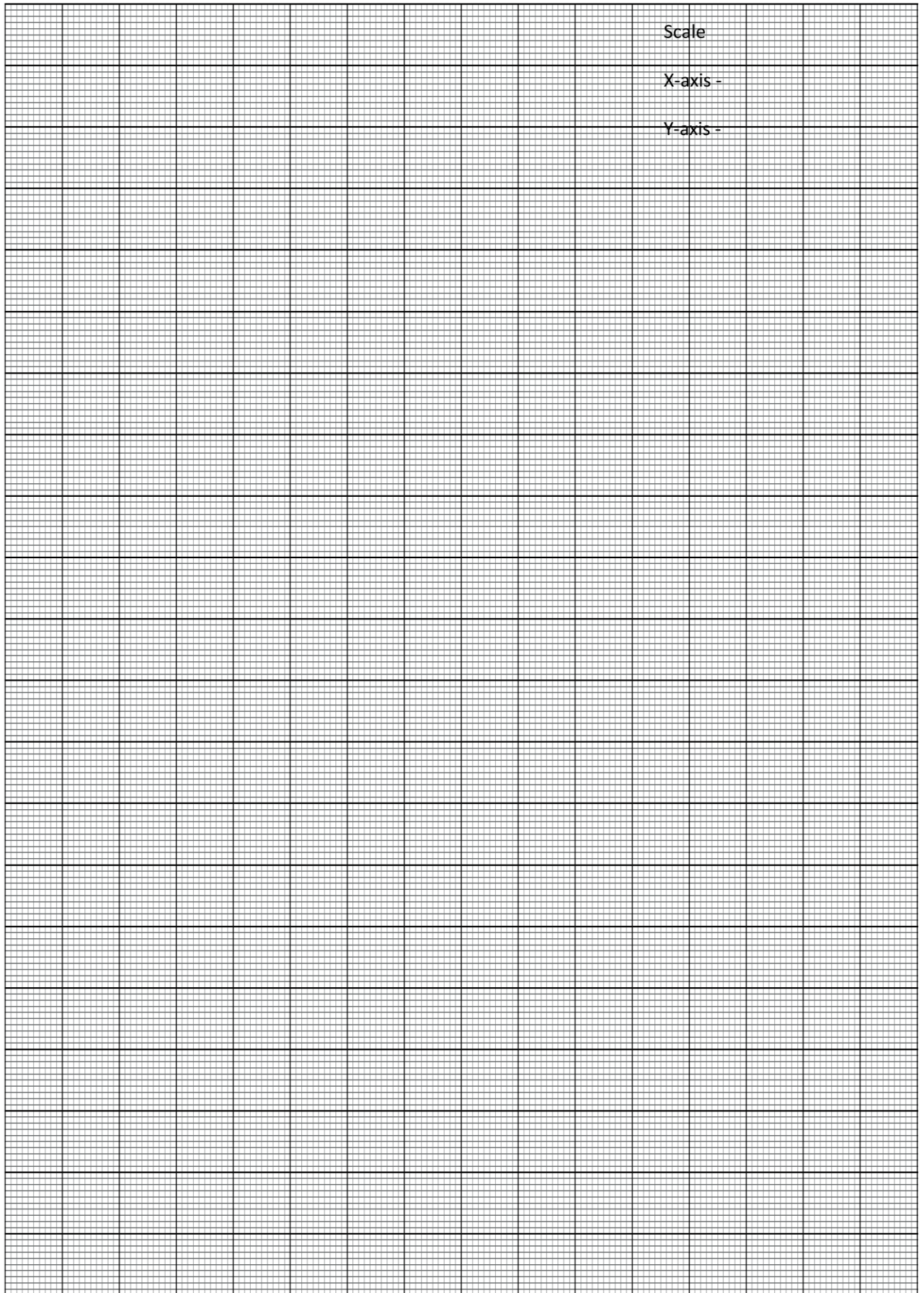

Practical No:- 04 Determination of specific resistance of given wire

I Practical Significance

In industries, components like resistors, inductors and chokes all have to verify that their product meets the requirements of specific resistance, tolerance, and quality control testing. Resistivity or specific resistance (ρ) is a measure of the resistance offered to the electrical conduction for a given size of material. To remove the effect of size from resistance, specific resistance is used. This is a material property which does not depend on size.

II Industry/ Employer Expected Outcome

Apply principles of physics and chemistry to solve broad based relevant engineering problems

III Course Level Learning Outcome

Apply the basic principles of electromagnetics to solve given engineering problems.

IV Laboratory Learning Outcome(s)

Determine the specific resistance of given wire.

V Relevant Affective domain related Outcomes

- Circuit connections Skills.
- Measurement Skills.
- Experiments and practice

VI Relevant Theoretical Background

Ohm's Law: It states that "Provided the physical conditions of a conductor remaining the same (length, area, temperature of the conductor), in a closed circuit the amount of current (I) flowing through the conductor is directly proportional to the potential difference (V) between two ends of the conductor."

$$V \propto I$$

$V = IR$ Where R is resistance of conductor.

Factors affecting resistance of a conductor At constant temperature, resistance (R) of the conductor is directly proportional to the length of the conductor and inversely proportional to its cross sectional area.

$$R \propto L$$

$$R \propto \left(\frac{1}{a}\right)$$

$$R = \rho \cdot \frac{L}{a}$$

where ρ is specific resistance or resistivity of material.

Specific resistance : It is defined as the resistance of a material per unit length per unit cross sectional area when temperature of conductor is constant.

$$\rho = R a/L$$

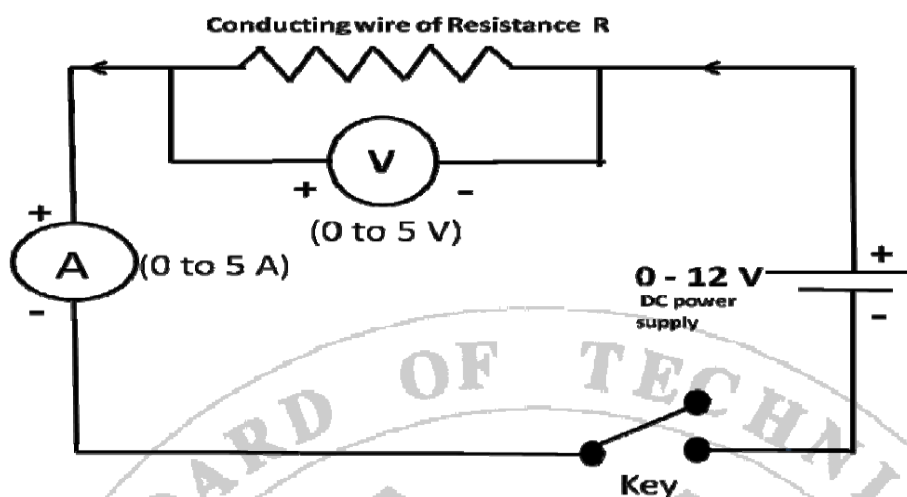
VII Circuit Diagram / Experimental set up / Work Situation.**VIII Resources required**

Sr. No.	Particulars	Specification	Quantity
1	Voltmeter	0-5V	01
2	Ammeter	0-1A	01
3	Battery	0-12V	01
4	Metal wire	20cm,30cm,40cm,50cm,60cm,70cm,80cm, 90cm or as available	01 each
5	Resistance box	0-1000 ohm	01

IX Precautions

1. Handle all the equipments with care.
2. Make connections according to circuit diagram.
3. The plug key should be open while connecting the circuit
4. Get the connections checked by the teacher.
5. Before switching on the supply, the knob of the DC supply should be strictly kept at 0 V (minimum)
6. Take the readings carefully & the connections should be tight.

X Procedure

1. Measure the radius 'r' of wire using micrometer screw gauge.
2. Determine the area 'a' of the wire using the formula.
3. Find L.C. and range of the given ammeter and voltmeter.
4. Take conducting wire of known length (L).
5. Connect the circuit as per circuit diagram.

6. Now put in the plug key.
7. Switch on the circuit.
8. For a constant supply voltage (V), note down the current (I) using the ammeter.
9. By keeping the voltage constant, note the current (I) for wires of different length.
10. Calculate the resistance (R) of the wire using the formula, $R = V / I$
11. $R = V / I$
12. Calculate the value of specific resistance using the formula, $\rho = Ra / L$
13. Plot the graph of resistance(R) Vs length (L) of the wire.
14. Find the slope of the graph.
15. From the value of slope, determine the specific resistance of the given wire using the formula $\rho = \text{Slope} \times \text{Area (a)}$.
16. Compare the experimental and graphical value of the specific resistance of the given wire.

XI Observations and Calculations

To determine the radius and hence area of the given wire:

Dimension	MSR cm	CSD	CSR= (CSD X L.C.) cm	TR= (MSR + CSR) cm	CR TR \pm (z) cm	Average reading d cm	Area of Cross- section $a = \pi r^2$ cm ²
Diameter (d) of Wire	1						
	2						
	3						

Observation Table:

1. Least count of ammeter =..... A.
2. Range of ammeter=..... A.
3. Least count of voltmeter.=..... V
4. Range of voltmeter= V

To determine the specific resistance (ρ) of the wire

Obs. No.	Length of wire (L) in cm	Current (I) in ampere	Potential difference (V) in volt	Resistance of Wire $R = V / I \quad \Omega$	Specific resistance $\rho = Ra / L \quad \Omega\text{-cm}$
1	20				
2	30				
3	40				
4	50				
5	60				
6	70				
7	80				
8	90				

Calculations

Specific Resistance

$$\rho = \frac{Ra}{L}$$

$\rho =$ _____

Specific resistance of the material of the given wire by graph

Graph:

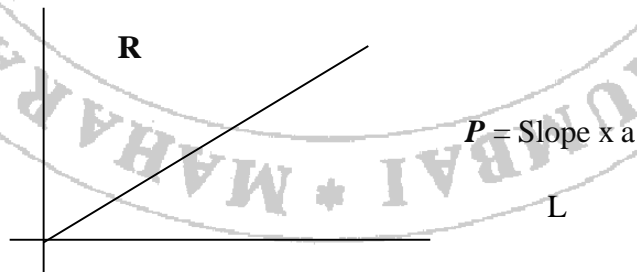

XII Results

1. Mean Resistance for wire of length of wire = n
2. Specific resistance of the material of given wire by experiment = $\Omega\text{ cm}$.
3. Specific resistance of the material of given wire by graph = $\Omega\text{ cm}$

XIII Interpretation of results

Error in the value of specific resistance=Experimental value- Standard value

XIV Conclusions and Recommendations

XV Practical Related Questions

Note: Below given are few sample questions for reference. Teachers must design more such questions so as to ensure the achievement of identified CO.

1. State the factors on which specific resistance of the wire depends in your experiment.
2. For two wires of same length and different radii, does the resistance of wire change? Give reasons.
3. Name the different methods of finding unknown resistance.
4. Calculate the resistance of a copper wire 20 meter long and diameter of 0.05 cm. (specific resistance of copper = $1.678 \times 10^{-6} \Omega\text{-cm.}$)
5. If the radius wire is doubled, will the specific resistance change? Explain.

[Space to Write Answers]

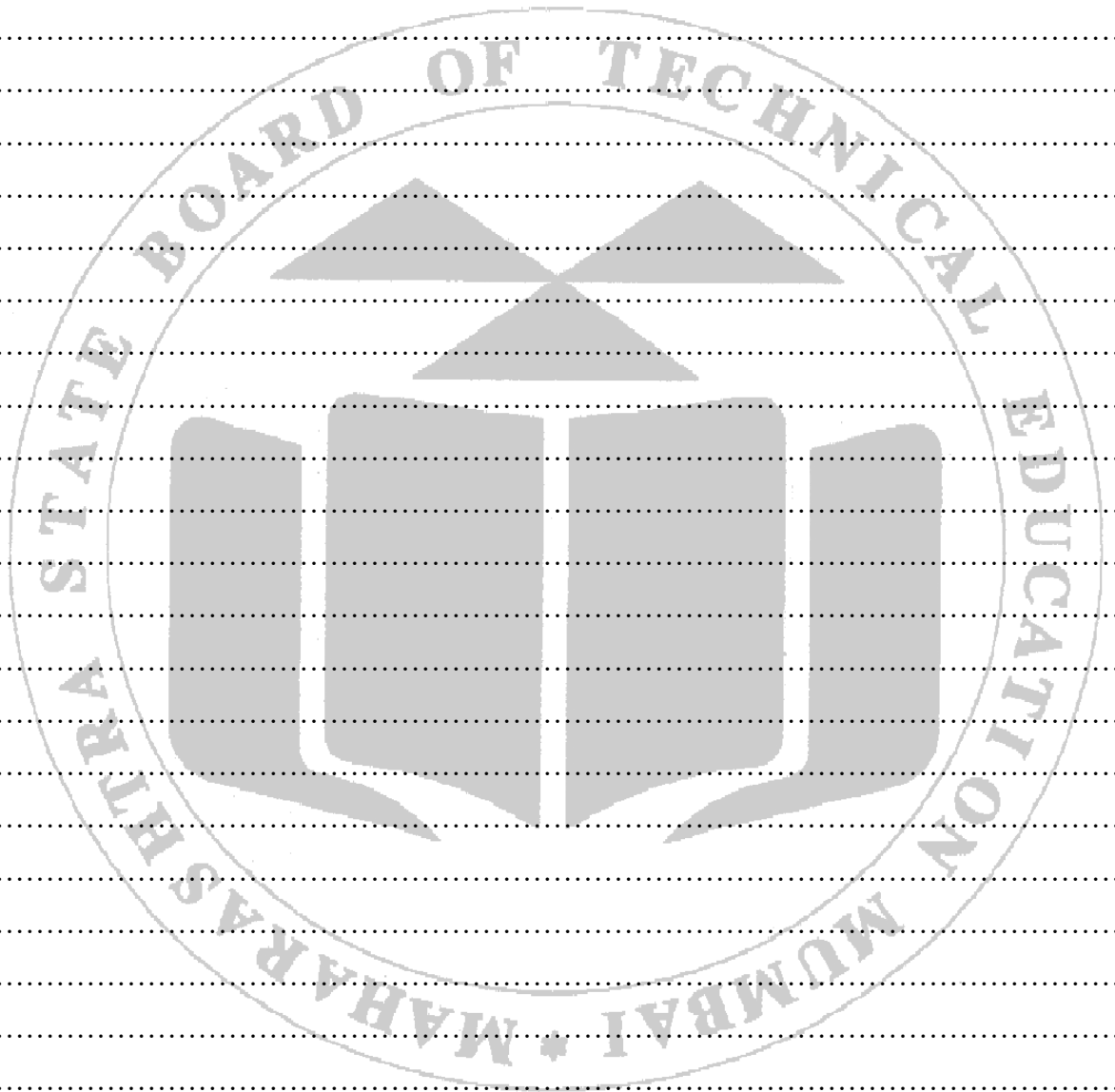

XVI References / Suggestions for further Readings

1. https://phet.colorado.edu/sims/html/resistance-in-a-wire/latest/resistance-in-a-wire_en.html
2. <https://www.youtube.com/watch?v=ReHgm0jR9Hg>
3. <https://www.youtube.com/watch?v=ns9UtQUU9-Q>

XVII Assessment Scheme

Performance indicators		Weightage
Process related: 15 Marks		60%
1.	Handling of the instrument	10
2.	Arrangement of Practical set up	10
3.	Observation & Observation Table	10
4.	Calculation	10
5.	Result	10
6.	Team Spirit	10
Product related: 10 Marks		40%
1.	Timely Submission	10
2.	Interpretation of result	10
3.	Conclusions & Recommendations	10
4.	Practical related questions	10

List of Student Team Members.

1.
2.
3.
4.

Marks Obtained			Dated Signature of Faculty
Process Related (15)	Product Related (10)	Total (25)	

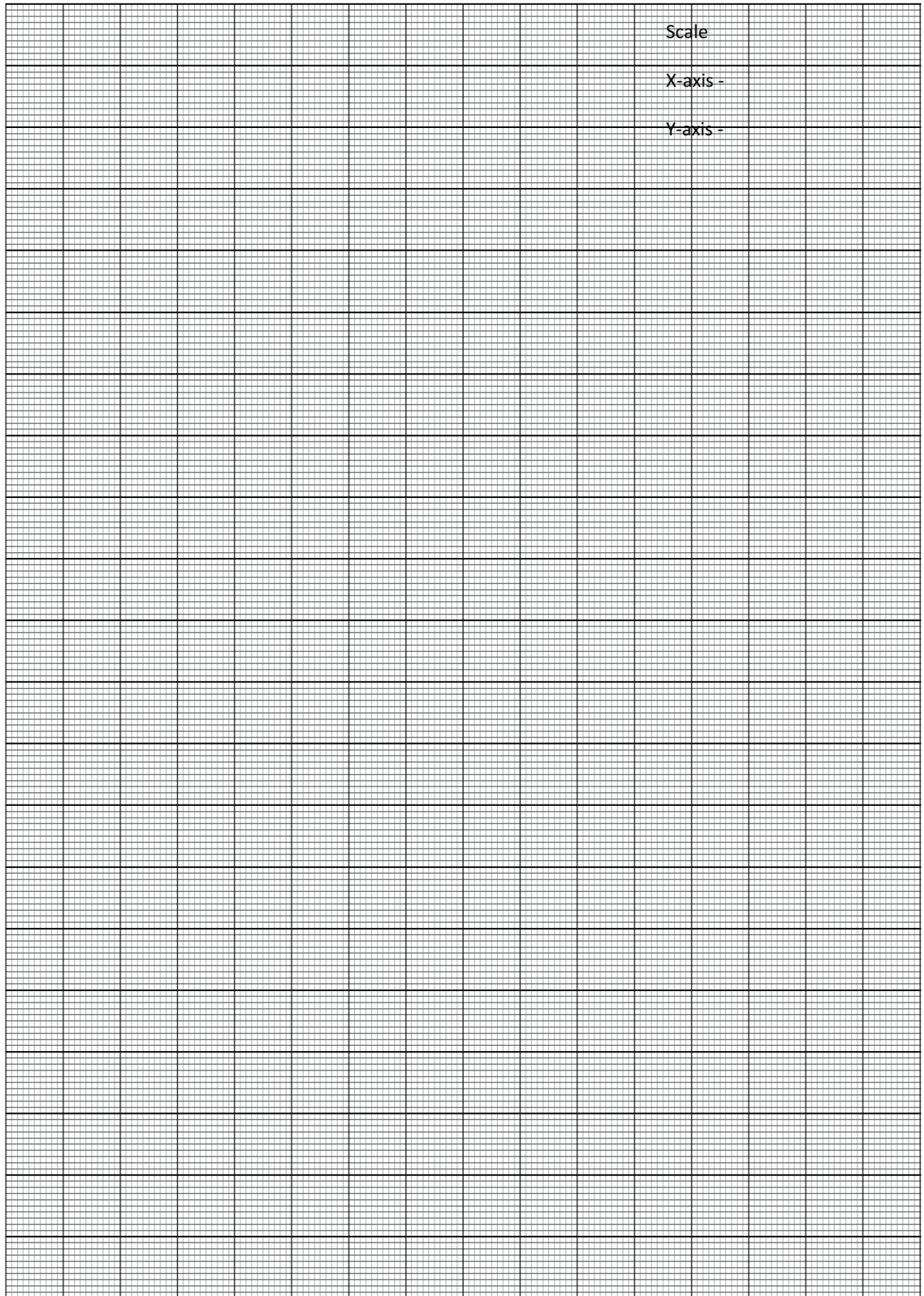

Practical No. 05: Determination of equivalent resistance in series connection of resistors.

I Practical Significance

Series circuit connections are common and greatly employed in electrical equipments. Current controlling devices, Fuses, automatic house-heating equipment electromagnetic coils and safety cut-outs connected in series with a voltage source. The application of series and parallel circuit connection can be evidently seen in our homes and industry. In this experiment, resistive wires are connected in series and equivalent resistance of circuit is determined using ohm's law, helps students to analyze series circuits.

II Industry/ Employer Expected Outcome

Apply principles of physics and chemistry to solve broad based relevant engineering problems.

III Course Level Learning Outcome

Apply the basic principles of electromagnetics to solve given engineering problems.

IV Laboratory Learning Outcome(s)

Verify law of series connection of resistors.

V Relevant Affective domain related Outcomes

1. Circuit connections Skills.
2. Measurement Skills.
3. Experiments and practice

VI Relevant Theoretical Background

1. Ohm's Law

It states that, physical conditions of a conductor such as length, area of cross section, temperature, resistivity remaining the same, in a closed circuit amount of current (I) flowing through the conductor is directly proportional to the potential difference (V) between two ends of the conductor.

$$I \propto V$$

$$I = V/R$$

2. Series circuit

A series circuit is a circuit in which resistors or loads are connected end to end so that the circuit will have only one path through which electric current flows. Thus, when a number of resistors are connected in series, the effective resistance (total resistance in the circuit) is obtained by adding the individual resistance algebraically. That is to say, if we have resistors with resistance $R_1, R_2, R_3 \dots R_n$ connected in series, then;

$$R_{\text{eff}} = R_s = R_1 + R_2 + R_3 + \dots R_n.$$

In series connections, the same current flows across all the branches of the circuits, but different voltage across it thus making the resistors to have different voltage across them. Each resistor or load will experience a voltage drop. The applied voltage is equal to the sum of the voltage drop across the different parts of the circuit. Voltage drop is proportional to the resistance current being the same throughout the circuit.

When loads are connected in series, the loads will tend to have a common switch. This kind of connection is employed in halls, street lights.

3. Law of resistances in series

It states that equivalent resistance of the resistances connected in series is sum of individual resistances

$$R_s = R_1 + R_2 + R_3 + \dots R_n$$

VII Circuit Diagram / Experimental set up / Work Situation.

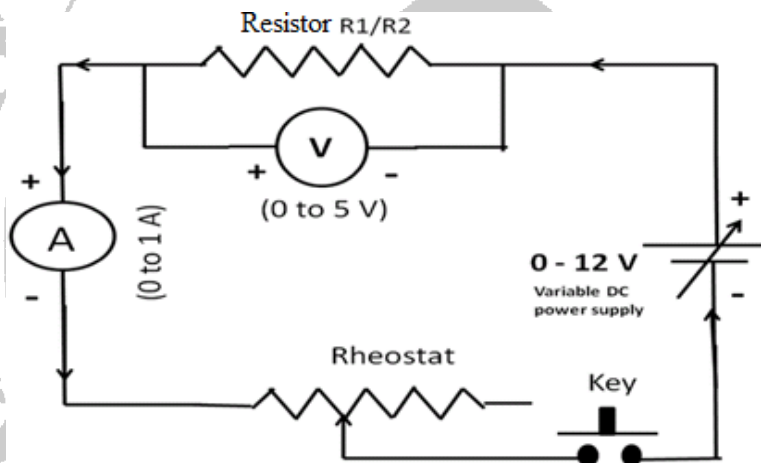
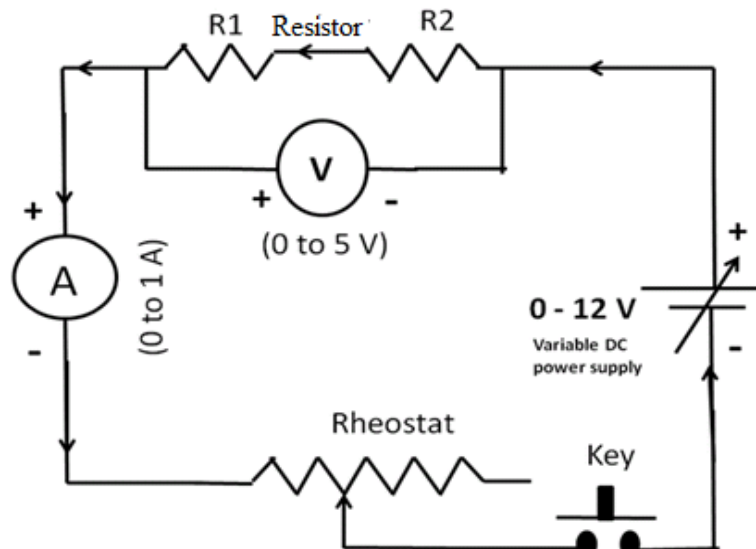

Fig.01



VIII Resources required

Sr.No.	Name of Instrument	Specifications	Quantity
1	Eureka wire	1m,2m	1 each
2	Copper wire	Multi-strand	1 bundle
3	Voltmeter	0-5V	1
4	Ammeter	0-1A	1
5	Rheostat	50-1100	1
6	Battery eliminator	0-6V	1

IX Precautions

1. Connections should be clean and tight.
2. Thick copper wires should be used for connection after removing the insulations near the ends.
3. While changing the voltage, rheostat must be move in one direction only.
4. Voltmeters and ammeters should be of proper range.
5. A low resistance rheostat should be used.
6. The key should be inserted only while taking the observations, to avoid excessive heating of resistors.
7. Do not pass a large current through the resistance.
8. While measuring the voltage and current the needle of meters should not move out of the scale.

X Procedure

1. Connect the circuit according to the circuit diagram (Fig. 01).
2. Connect unknown resistance R_1 in the circuit.
3. Vary current in the circuit using rheostat.
4. Record the observations from voltmeter and ammeter in equal intervals.
5. Take five observations.
6. Calculate the resistance of given wire by ohm's law as per the formula.
7. Find mean resistance R_1 .
8. Repeat the steps 2 to 7 to calculate unknown resistance R_2 .
9. Connect the two resistances R_1 and R_2 in series combination as per the circuit diagram (Fig. 02).
10. Repeat the steps 2 to 7 to calculate equivalent resistance R_s by experiment.
11. Calculate equivalent resistance R_s by theory using formula.
12. Show sample calculation.
13. Note down the results.
14. Write interpretation and conclusion.

XI Observations and Calculations

Range of Voltmeter = V

Range of Ammeter= A

Least count of voltmeter= V

Least count of ammeter= A

e.m.f of the Battery= V

Table No. 1

Sr. No.	Voltage volt (V)	Current Ampere (A)	Resistance $R_1 = V/I$ Ω	Mean Resistance Ω
01				
02				
03				
04				
05				

Table 2: For wire 2 (Fig.01)

Sr. No.	Voltage volt (V)	Current Ampere (A)	Resistance $R_2 = V/I$ Ω	Mean Resistance Ω
01				
02				
03				
04				
05				

Table 3: For wire 1 in series with wire 2 (Fig. 02)

Sr. No.	Voltage volt (V)	Current Ampere (A)	Resistance $R_s = V/I$ Ω	Mean Resistance Ω
01				
02				
03				
04				
05				

Calculations

- 1 & 2 and show the sample
- Sample calculation of resistance of wire
- (Students should consider any one observation from table calculation)
 - $R = V/I$ (By using Ohm's law)
- Calculation of equivalent resistance in series combination By theory,
- (Students should consider mean values R_1 and R_2 observation from table 1 & table 2 and show the sample calculation)
- $R = R_1 + R_2$

XII Results

Value of resistance of wire 1 (R_1)	Value of resistance of wire 1 (R_2)	Equivalent resistance of series combination of resistances (R_s)
BY Experiment	BY Experiment	BY Theory /Experiment

XIII Interpretation of results

.....

.....

XIV Conclusions and Recommendations

.....

.....

XV Practical Related Questions

Note: Below given are few sample questions for reference. Teachers must design more such questions so as to ensure the achievement of identified CO.

1. Write the function of rheostat in the circuit used.
2. Calculate the potential difference required to pass a current of 5A through a metallic rod of resistance 10 Ω .
3. Three resistors of resistances 250, 500, and 750 respectively are connected in series in a circuit. What is the effective resistance of the combination of the three resistors?
4. If the voltage across a fixed value of resistance is increased five times, what will be the variation in current?
5. Three resistances of 15, 10, and 20 ohms are connected in series. Find the equivalent resistance for the system.

[Space to Write Answers]

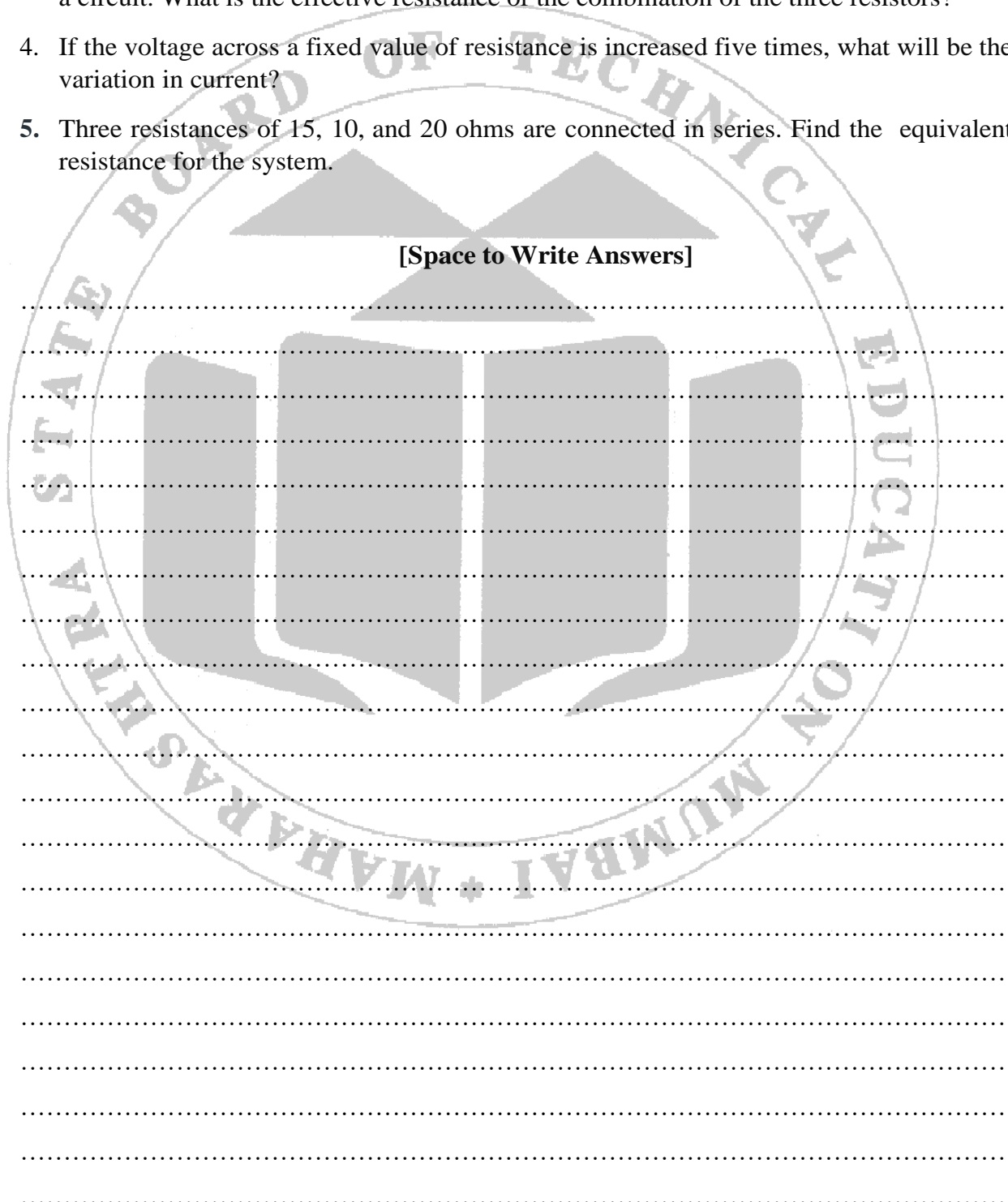

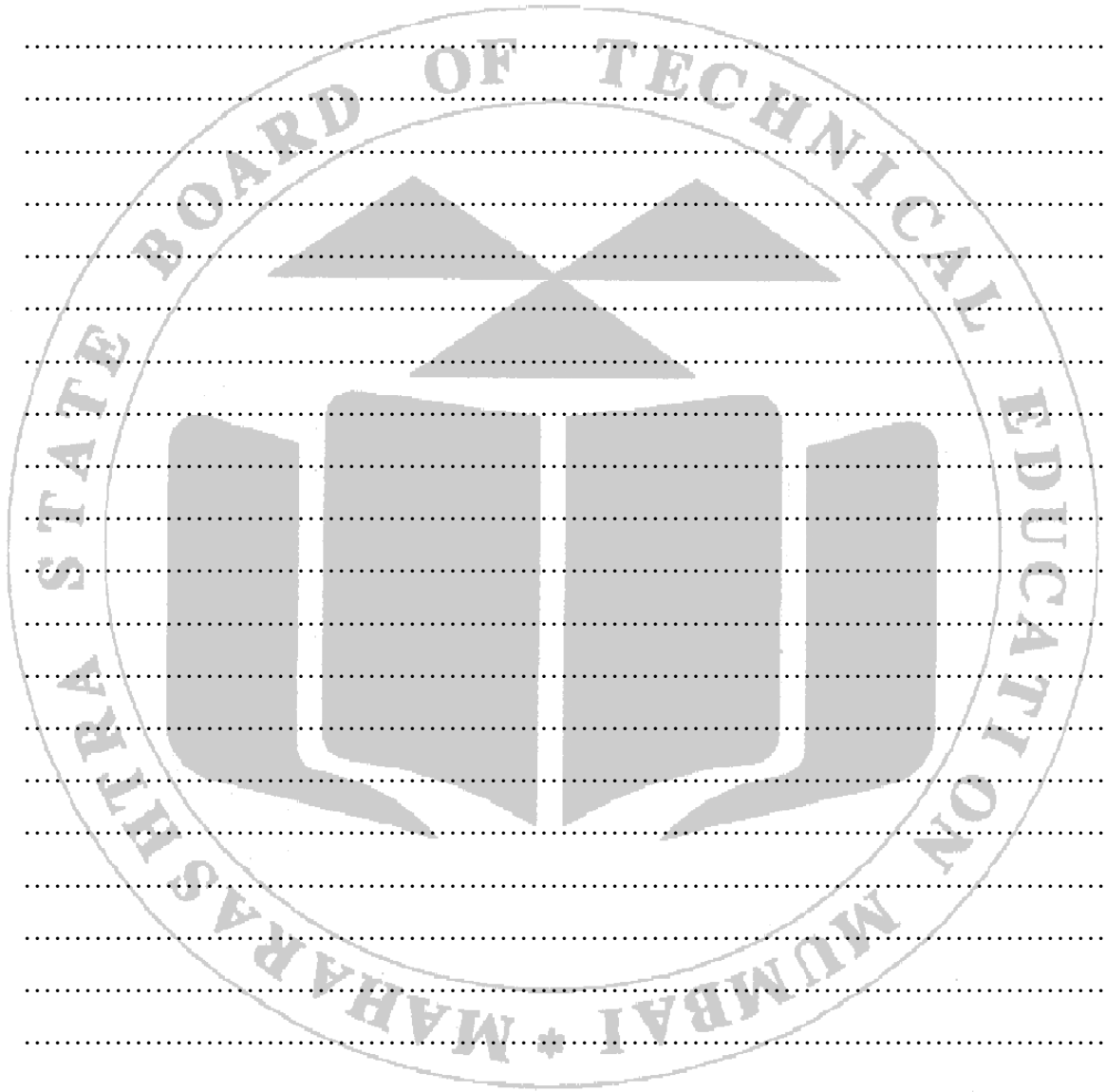

XVI References / Suggestions for further Readings

1. <https://youtu.be/xWYKM-mDryo>
2. <https://youtu.be/Q3yFLn63VLI>
3. <https://www.youtube.com/watch?v=pd3RkGs1Tsg>

XVII Assessment Scheme

Performance indicators		Weightage
Process related: 15 Marks		60%
1.	Handling of the instrument	10
2.	Arrangement of Practical set up	10
3.	Observation & Observation Table	10
4.	Calculation	10
5.	Result	10
6.	Team Spirit	10
Product related: 10 Marks		40%
1.	Timely Submission	10
2.	Interpretation of result	10
3.	Conclusions & Recommendations	10
4.	Practical related questions	10

List of Student Team Members.

1.
2.
3.
4.

Marks Obtained			Dated Signature of Faculty
Process Related (15)	Product Related (10)	Total (25)	

Practical No. 6: Determination of equivalent resistance in parallel connection of resistors.**I Practical Significance**

In industry, parallel circuits are one of the main building blocks used in the infrastructure that supplies power to large populations. By making use of parallel circuits, engineers have been able to create power grids that are more secure and more efficient. Parallel circuits also make it easier to provide an equal power. Parallel circuits are used inside many electrical devices and appliances. Using parallel circuits, a device takes an equal amount of power from different sources and combines it on the same line. The most familiar use of parallel circuits is found in lighting fixtures. If one bulb bums out, the other bulbs in the fixture continue to operate. Other uses include an electronic OR gate, where two switches are in a parallel circuit: one of the switches must be closed for the circuit to function. If both sides are closed, the circuit will not function. Household wiring is a series of parallel circuits. In this lab experience, equivalent resistance is found using parallel combination of resistors supply to different sectors.

II Industry/ Employer Expected Outcome

Apply principles of physics and chemistry to solve broad based relevant engineering problems.

III Course Level Learning Outcome

Apply the basic principles of electromagnetics to solve given engineering problems.

IV Laboratory Learning Outcome(s)

Verify law of parallel connection of resistors.

V Relevant Affective domain related Outcomes

1. Circuit connections Skills.
2. Measurement Skills.
3. Experiments and practice

VI Relevant Theoretical Background**1) Ohm's Law**

It states that, physical conditions of a conductor such as length, area of cross section, temperature, resistivity remaining the same, in a closed circuit amount of current (I) flowing through the conductor is directly proportional to the potential difference (V) between two ends of the conductor.

$$I \propto V$$

$$I = \frac{V}{R} \text{ Where } R \text{ is the resistance of conductor.}$$

2) Law of resistances in parallel

The law states that the effective resistance in parallel combination is the sum of reciprocal of all resistance which are connected in parallel combination.

Hence the equation is

$$\frac{1}{R} = \frac{1}{R_1} + \frac{1}{R_2}$$

$$R = \frac{R_1 \times R_2}{R_1 + R_2}$$

VII Circuit Diagram / Experimental set up / Work Situation.

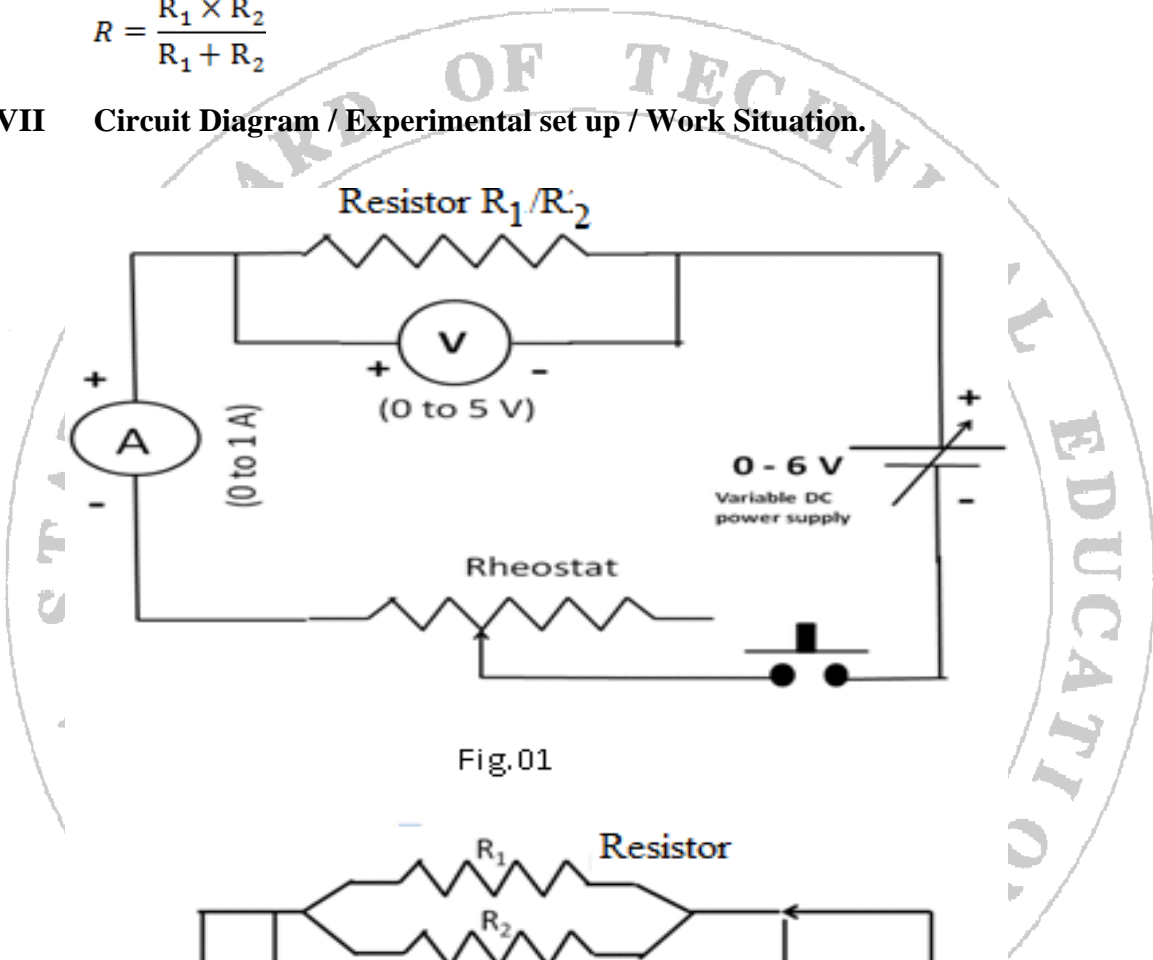

Fig.01

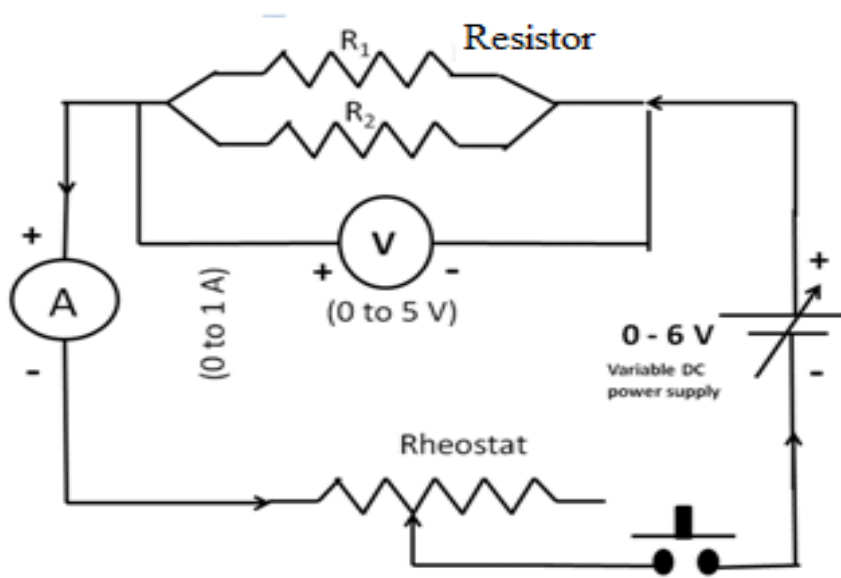

Fig. 02

VIII Resources required

Sr.No.	Name of Instrument	Specifications	Quantity
1	Eureka Wire(Copper Nickel alloy)	1 m and 2 m	3 No.
2	Copper wire	Multistrand	3 No.
3	Voltmeter	0-5V	1 No.
4	Ammeter	0-SA	1 No.
5	Rheostat	0-300 Q	1 No.
6	Power Supply	0-12V, 0-5A	1 No.

IX Precautions

1. Connections should be clean and tight.
2. Thick copper wires should be used for connection after removing the insulations near the ends.
3. While changing the voltage, rheostat must be moving in one direction only.
4. Voltmeters and ammeters should be of proper range.
5. A low resistance rheostat should be used.
6. The key should be inserted only while taking the observations to avoid excessive heating of resistors.
7. Pass a current through the resistance as per power rating.
8. While measuring the voltage and current the needle of meters should not move out of the scale.

X Procedure

1. Connect the circuit as shown in circuit diagram 1.(Fig 1)
2. Connect unknown resistance R1 in the circuit.
3. Vary current in the circuit using rheostat.
4. Record the observations from voltmeter and ammeter in equal intervals.
5. Take five observations.
6. Calculate the resistance of given wire by ohm's law as per the formula.
7. Find mean resistance R1
8. Repeat the steps 2 to 7 to calculate unknown resistance R2.
9. Connect the two resistances R1 and R2 in parallel combination as per the circuit diagram.
10. Repeat the steps 2 to 7 to calculate equivalent resistance Rp by experiment.
11. Calculate equivalent resistance Rp by theory using formula.

XI Observations and Calculations

1. Range of Voltmeter = _____ V
2. Range of Ammeter = A
3. Least count of voltmeter = V
4. Least count of ammeter = A
5. e. m. f of the Battery = V

Table 1: For wire 1

Sr. No.	Voltage Volt (V)	Current Ampere (A)	Resistance $R_1 = V/I$ Ω	Mean Resistance Ω
1				
2				
3				
4				
5				

Table 2: For wire 2

Sr. No.	Voltage Volt (V)	Current Ampere (A)	Resistance $R_2 = V/I$ Ω	Mean Resistance Ω
1				
2				
3				
4				
5				

Table 3: For wire 1 in parallel with wire 2

Sr. No.	Voltage Volt (V)	Current Ampere (A)	Resistance $R_p = V/I$ Ω	Mean Resistance R_p Ω
1				
2				
3				
4				
5				

Calculations

$$\frac{1}{R_p} = \frac{1}{R_1} + \frac{1}{R_2}$$

$$R_p = \frac{R_1 \cdot R_2}{R_1 + R_2}$$

XII Results

Value of resistance of wire 1 (R ₁)	Value of resistance of wire 2 (R ₂)	Equivalent resistance of parallel combination of resistances (R _s)
BY Experiment	BY Experiment	BY Theory /Experiment

XIII Interpretation of results**XIV Conclusions and Recommendations****XV Practical Related Questions**

Note: Below given are few sample questions for reference. Teachers must design more such questions so as to ensure the achievement of identified CO.

1. Write the range of the ammeter used in experiment.
2. Find the equivalent resistance between point A & B.



3. If two resistance 3ohm & 4 ohm are connected in parallel.then what is the equivalent resistance in the circuit.
4. When the resistance are connected in parallel effective resistance increases or decreases ?
5. State law of resistance in parallel.

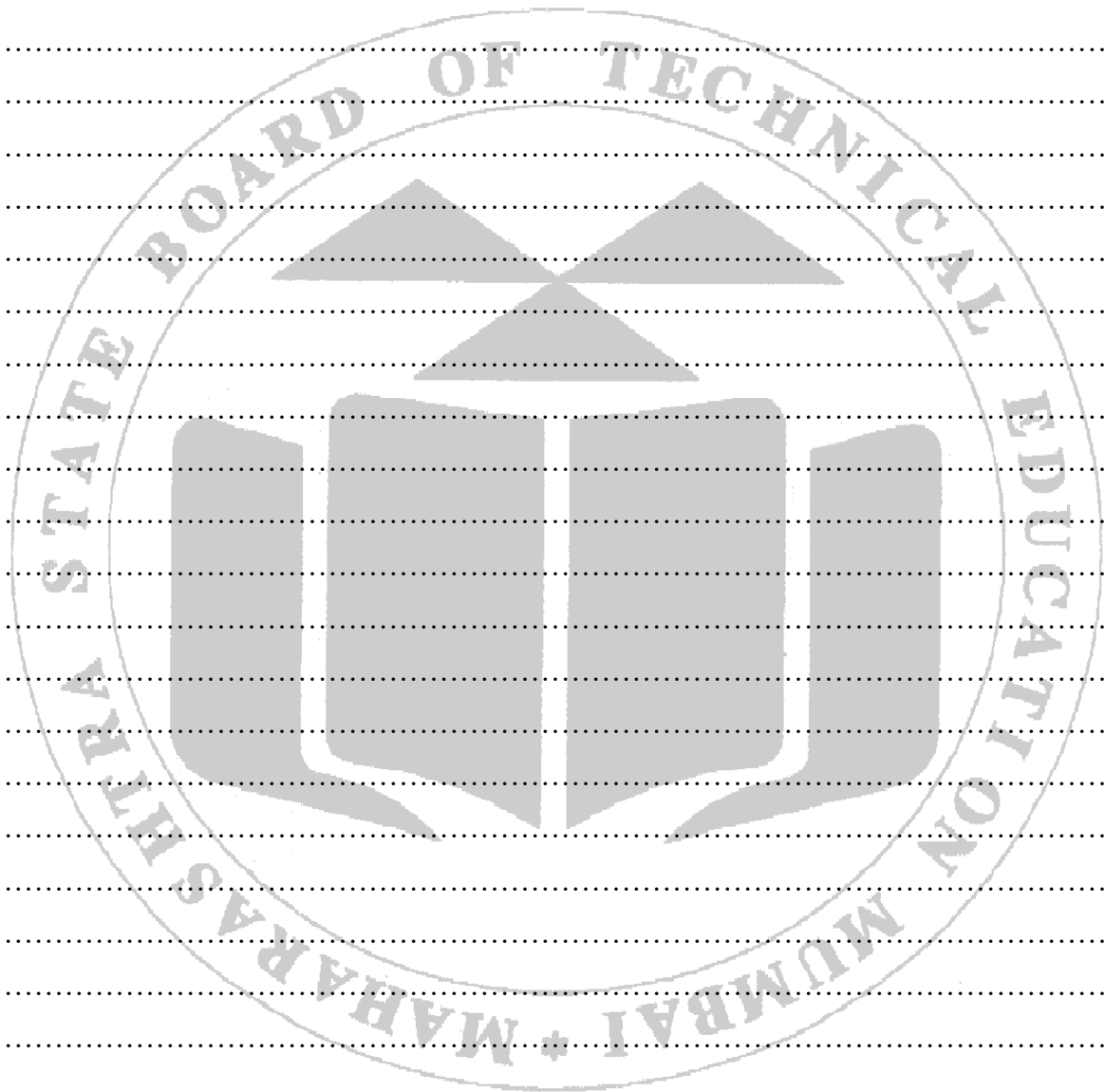

XVI References / Suggestions for further Readings

- https://phet.colorado.edu/sims/html/circuit-construction-kit-dc-virtual-lab/latest/circuit-construction-kit-dc-virtual-lab_all.html
- <https://youtu.be/w0xw9MHBMiI>
- https://www.youtube.com/watch?v=s0Pk34_yN-Y

XVII Assessment Scheme

Performance indicators		Weightage
Process related: 15 Marks		60%
1.	Handling of the instrument	10
2.	Arrangement of Practical set up	10
3.	Observation & Observation Table	10
4.	Calculation	10
5.	Result	10
6.	Team Spirit	10
Product related: 10 Marks		40%
1.	Timely Submission	10
2.	Interpretation of result	10
3.	Conclusions & Recommendations	10
4.	Practical related questions	10

List of Student Team Members.

-
-
-
-

Marks Obtained			Dated Signature of Faculty
Process Related (15)	Product Related (10)	Total (25)	

Practical No.7: Determination of neutral points by magnetic compass.

I Practical Significance

All the navigation devices used in radars, airplane, ships, surveying and mountaineering used earth's magnetic field to determine geographical directions. Magnets are used in electric motors, transformers and generators. Magnetic field produced by magnets depends upon the shape, size and material of magnets. In this experiment a student will determine the nature of magnetic field produced by bar magnet and null point formed due to combination of horizontal component of earth's magnetic field and magnetic field of bar magnet.

II Industry/ Employer Expected Outcome

Apply principles of physics and chemistry to solve broad based relevant engineering problems.

III Course Level Learning Outcome

Apply the basic principles of electromagnetics to solve given engineering problems.

IV Laboratory Learning Outcome(s)

Use magnetic compass to draw the magnetic lines of forces of magnet of different shapes and determine neutral points

V Relevant Affective domain related Outcomes

- a) Practice good housekeeping.
- b) Demonstrate working as a leader/a team member.
- c) Handling the instrument carefully.

VI Relevant Theoretical Background

1) Neutral Points in a Magnetic Field

At a particular point, if the compass needle does not point in any particular direction, then there is no net magnetic field at the point. Such a point is called Neutral point or the Null point. A neutral point is a point where the resultant magnetic field is zero. The two points on either side of the bar magnet at equal distances from its centre, where the compass needle does not show any specific direction. At these points, the magnetic field induction B due to the bar magnet and

the horizontal component of the earth's magnetic field induction, B_0 are equal in magnitude and opposite in direction. The resultant magnetic field is zero. These points represent the neutral points denoted by N_1 and N_2 . These two

points fall on the equatorial line of the bar magnet.

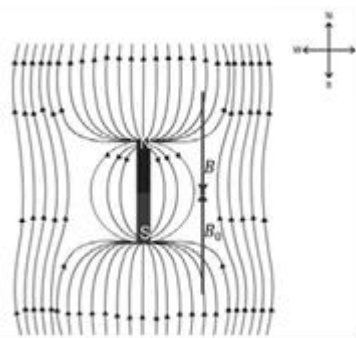
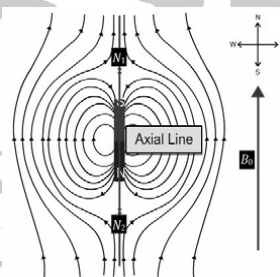

Fig. 01 North pole of bar magnets points towards the north pole of earth.

Thus, when the north pole of a bar magnet points towards the geographical north pole of the earth, the two neutral points lie on the equatorial line of the bar magnet such that they are equidistant from the centre of the bar magnet.

North Pole of bar magnets points towards the north pole of earth.

The two points along the axis and at equal distances from the centre of the magnet where the compass needle does not show any particular direction. At these points, the magnetic field induction B due to the bar magnet and the horizontal component of the earth's magnetic field induction, B_0 are equal in magnitude and opposite in direction. The resultant magnetic field is zero. These points represent



the neutral points, denoted by N_1 and N_2 . These two points lie on the axial line of the bar magnet.

Thus, when the south pole of a bar magnet points towards the geographical north pole of the earth, the two neutral points lie on the axial line of the bar magnet such that they are equidistant from the centre of the bar magnet. By locating the neutral points for a given bar magnet in the two cases, we can calculate its magnetic moment and pole strength.

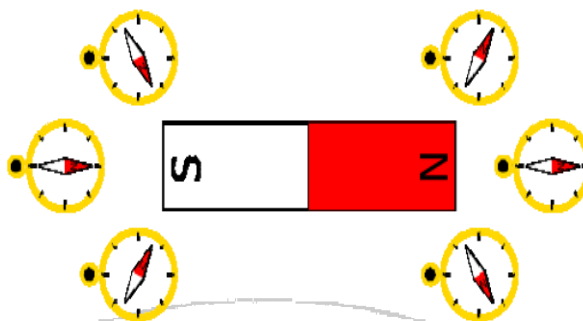
VII Circuit Diagram / Experimental set up / Work Situation.**VIII Resources required**

Sr. No.	Particulars	Specification	Quantity
1	Bar Magnet	5cm or as per available	01
2	White Paper	A4 size	01
3	Magnetic Compass		01

IX Precautions

1. All the point must be traced very accurately and neatly using a compass.
2. A sharp pencil must be used to draw all the magnetic lines of forces.
3. Distance of neutral points must be measured from the centre of Bar Magnet.

X Procedure

Part (i): When the north pole of a bar magnet points towards the north pole of the earth.

1. Fix a sheet of white paper on a drawing board with brass pins.
2. Take a compass needle, place it at the centre of the paper.
3. Mark the north and south directions.
4. Draw a straight line along the paper connecting the two points.
5. Represent the magnetic meridian of the earth.
6. Represent the geographical directions at the corner of the paper.
7. Draw an arrow from the geographical south to the geographical north on the right side of the paper.
8. Indicate the direction of the horizontal component of the earth's magnetic field, B_0 .
9. Take a bar magnet and place it at the centre of the paper such that the north pole of the bar magnet points towards the North Pole of the earth.
10. Draw outline of bar magnet.
11. Now place the compass needle at the north pole of the bar magnet.
12. Mark a point at north-pole of the compass needle.
13. Shift the compass such that the south pole of the compass needle is at the point marked.
14. Mark another point at the north of the compass needle, and then shift the compass, as done in step 13.

15. Repeat the procedure till the compass needle reaches the other end of the bar magnet.
 - a. Join all the points to get a continuous smooth curve, which represents a magnetic field line.
16. Repeat the procedure from the north pole of the magnet, but from different points, and draw the magnetic field lines.

Part (ii): When the south pole of the bar magnet points towards north pole of the earth.

1. Take a new paper and repeat the steps 1 to 8 of part (i)
2. Take a bar magnet and place it at the centre of the paper such that the south pole of the bar magnet points towards the North Pole of the earth.
3. Draw outline of bar magnet
4. Repeat the steps 11 to 17 of part (i)

XI Observations and Calculations

Observing Natures of magnetic lines of force and locate the neutral points of bar magnets

- Length of bar magnet= cm.=.....m.
- Distance between the neutral points from center of bar magnets
- North Pole of bar magnets points towards the north pole of earth=..... cm
=.....m
- South Pole of bar magnets points towards the north pole of earth=..... cm
=.....m

XII Results

The neutral points are determined for the following cases
The nature magnetic lines of forces of bar magnet is as per sheet attached.
North Pole of bar magnets points towards the north pole of earth=..... m.
South Pole of bar magnets points towards the north pole of earth=..... m

XIII Interpretation of results

.....
.....
.....

XIV Conclusions and Recommendations

.....
.....
.....

XV Practical Related Questions

Note: Below given are few sample questions for reference. Teachers must design more such questions so as to ensure the achievement of identified CO.

1. Write reason for deflection in compass needle, when brought near bar magnet.
2. Give the number of neutral points obtained if we place a bar magnet in east west direction.
3. Write material and length of given bar magnet.
4. Give the position of the neutral point, when a bar magnet is placed with its South Pole pointing towards geographic north.
5. Write the neutral point formula?

[Space to Write Answers]

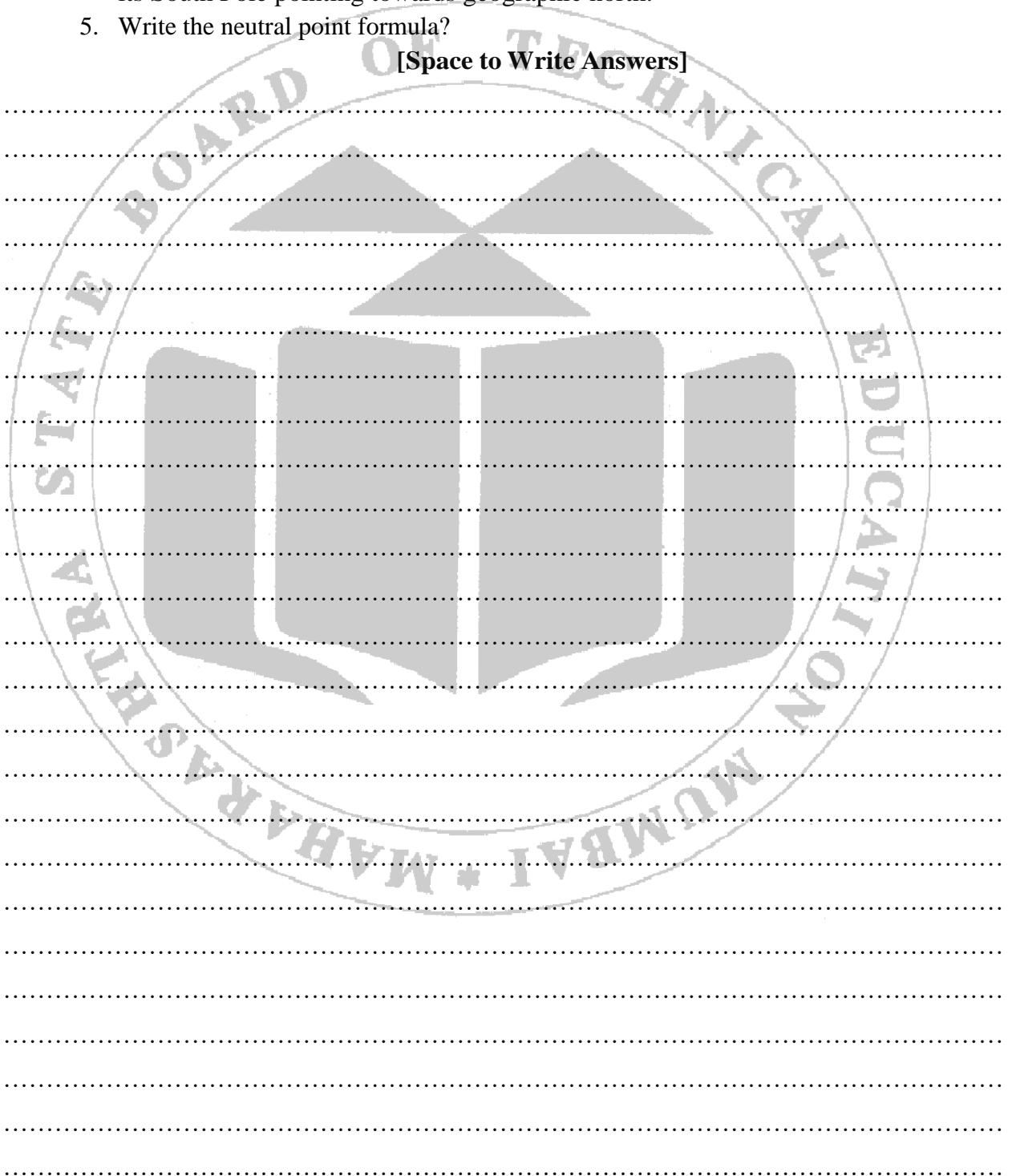

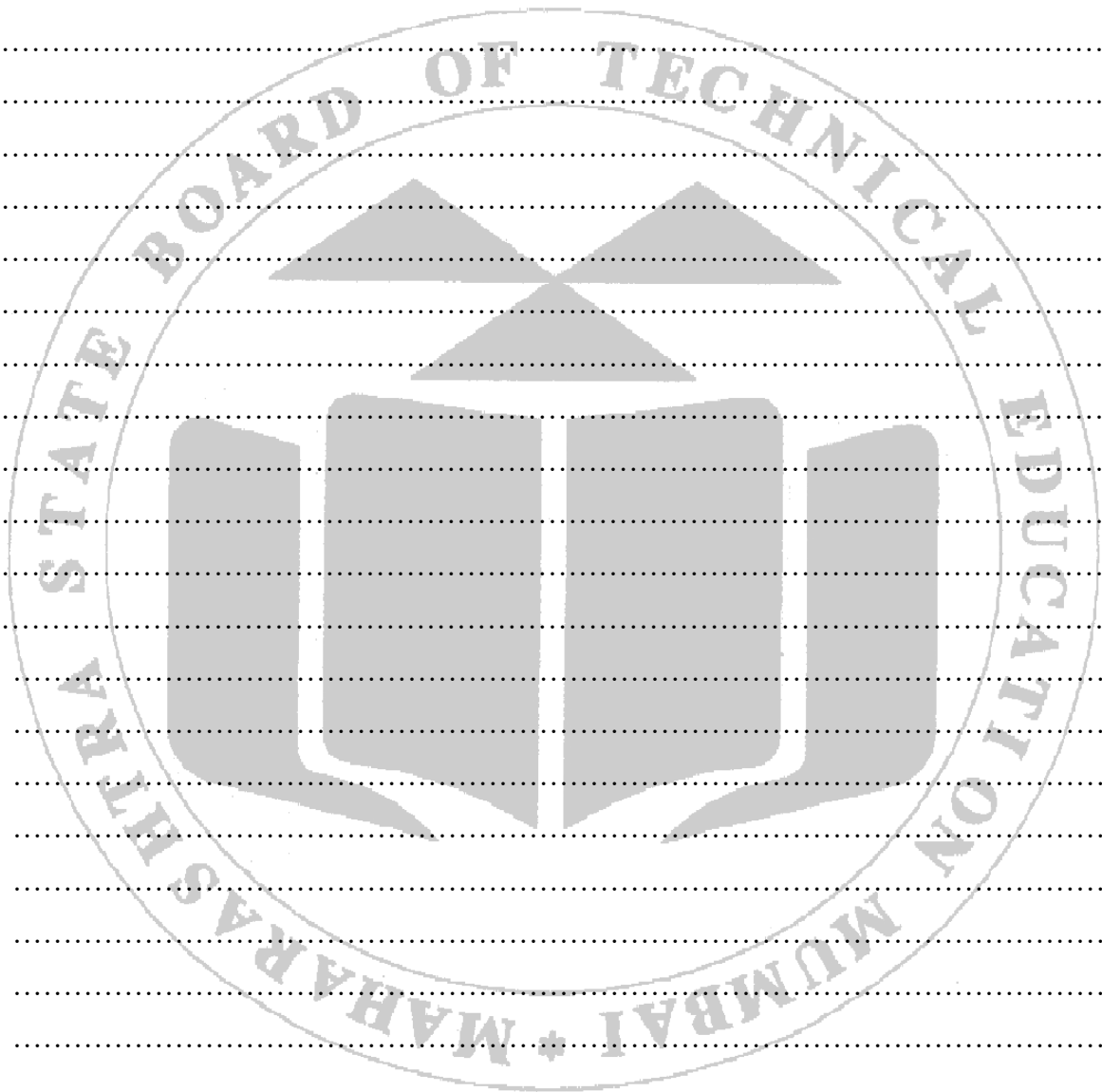

XVI References / Suggestions for further Readings

- a) <https://phet.colorado.edu/sims/cheerpj/faraday/latest/faraday.html?simulation=magnets-and-electromagnets>
- b) Physics text book of class xii (NCERT)
- c) Fundamental of physics by wiley -india lastly

XVII Assessment Scheme

Performance indicators		Weightage
Process related: 15 Marks		60%
1.	Handling of the instrument	10
2.	Arrangement of Practical set up	10
3.	Observation & Observation Table	10
4.	Calculation	10
5.	Result	10
6.	Team Spirit	10
Product related: 10 Marks		40%
1.	Timely Submission	10
2.	Interpretation of result	10
3.	Conclusions & Recommendations	10
4.	Practical related questions	10

List of Student Team Members.

1.
2.
3.
4.

Marks Obtained			Dated Signature of Faculty
Process Related (15)	Product Related (10)	Total (25)	

Practical No.8: Determination of static and dynamic resistance of given P N junction diode.

I Practical Significance

In industry, p-n junction diode has wide range of applications. Diode is used in clipping and wave shaping circuits in computers, radios and radar. It is used as switch in digital logic designs. Detector and demodulator circuits use diodes in TV receiver circuits Voltage multipliers and rectifiers circuits used in house hold appliances consists diodes. In this lab experience, students will determine the forward and reverse bias characteristics, static and dynamic resistance of p-n junction diode which helps in designing the circuits as per the required.

II Industry/ Employer Expected Outcome

Apply principles of physics and chemistry to solve broad based relevant engineering Problems.

III Course Level Learning Outcome

Apply the basic principles of electromagnetics to solve given engineering problems.

IV Laboratory Learning Outcome(s)

Use P -N junction diode to draw forward bias and reverse bias I-V characteristics

V Relevant Affective domain related Outcomes

- a. Handle tools and equipment carefully.
- b. Select instruments of required least count and range.
- c. Following safety measure.

VI Relevant Theoretical Background

Anode Cathode



Symbol of p-n junction diode

1. **Formation of p-n junction:** In p-type semiconductor, holes are the majority carriers and electrons are the minority carriers whereas in n-type semiconductor, electrons are the majority carriers and holes are the minority carriers. When p-type and n-type semiconductors are intimately joined together, p-n junction diode is formed. The boundary region of p type and n type semiconductors is called **p-n junction**. When a p-n junction is formed, some electrons from the n- region cross over the junction and move into the p- type. Here they recombine with the holes and the holes from the p-region cross over the junction and move into the n-region and recombine with the electrons. But the immobile charges (i.e. negative ions in p-region and positive ions in then-region) cannot cross over the junction. Thus there is a region formed on either side of the junction which contains immobile charges only. This region is called '**depletion region.**'

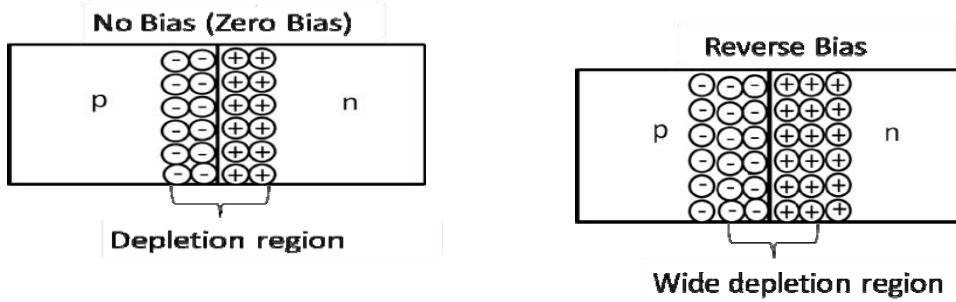

2. **Reverse bias:** When p-type semiconductor is connected to negative terminal of battery and n- type semiconductor is connected to the positive terminal of the battery, the junction is said to be reverse **biased**. The reverse voltage (V_R) at which the reverse current (I_R) becomes maximum is called **breakdown voltage**.

VII Circuit Diagram / Experimental set up / Work Situation.

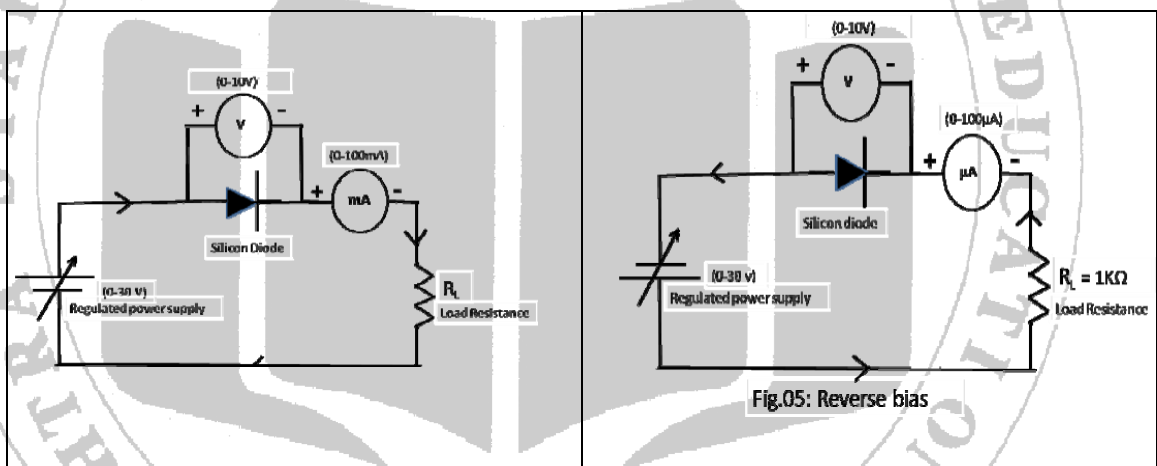

VIII Resources required

Sr. No.	Instrument	Specification	Quantity
1	Voltmeter	(0-1V),(0-30V)	1
2	Ammeter	(0-50milliamps) (0-500µA)	1
3	Resistor	1 kΩ	1
4	DC power supply	0-30 V	1
5	p-n junction diode	IN4001 ,IN4007	1
6	Connecting wires	Hook up wire	

IX Precautions

1. The current in the circuit should not exceed the current ratings of the diode.
2. Connect voltmeter and Ammeter in correct polarities.
3. Show the connections to concerned teacher and then switch ON the power Supply.

X Procedure

Part I: p-n junction diode in forward biased

1. Connect the p-n Junction diode in forward bias (Fig.04)
2. Connect the p-terminal (Anode) of the diode to positive terminal of the regulated power supply
3. Connect n-terminal (cathode) to the negative terminal of the regulated power supply.
4. Vary the supply voltage (V_f) in steps of 0.1V using the regulated power supply.
5. Record the corresponding values of forward current (I_f).
6. Plot a graph of forward current (I_f) Vs forward voltage (V_f)
 - i) Find its slope at a point where the the forward current (I_f) increases rapidly.
 - ii) Find the point of intersection on X-axis to obtain the knee voltage of the diode.
 - iii) Calculate reciprocal of the slope. This reciprocal gives the value of dynamic resistance of the diode.
 - iv) Locate the co-ordinates on the curve.
 - v) Find the static resistance at that point using the formula Static resistance = V_i/I_f

Part II: p-n junction diode in reverse biased

1. Connect the p-n Junction diode in reverse bias. (Fig. 05)
2. Connect the p-terminal (Anode) of the diode to negative terminal of the regulated power supply
3. Connect n-terminal (cathode) to the positive terminal of the regulated power supply.
4. Vary the supply voltage (V_R) in steps of using the regulated power supply till the current becomes maximum.
5. Record the corresponding values of reverse saturation current (I_R),
6. Note down this reverse breakdown voltage of the diode.

XI Observations and Calculations

Table 1: Forward Bias

Least count of voltmeter=.....V

Least count of milliammeter =.....mA

Sr. No.	Forward voltage (V_f) (volts)	Forward Current (I_f) (mA)
1		
2		
3		
4		
5		
6		
7		
8		
9		
10		

Graph of current (in mA) Vs voltage (in volts)

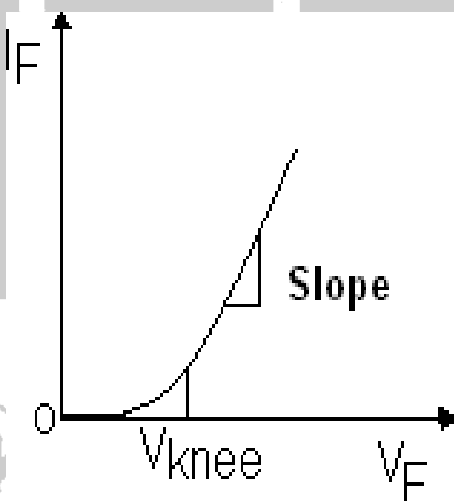

Observations from graph:

$\Delta V = \dots\dots\dots$ V

$\Delta I = \dots\dots\dots$ mA

$V_f = \dots\dots\dots$ V

$I_f = \dots\dots\dots$ mA

Calculations from the graph

Dynamic resistance = $\Delta V / \Delta I \dots\dots\dots \Omega$

Static resistance = $V_f / I_f = \dots\dots\dots$

Table 2: Reverse Bias

Least count of voltmeter = V

Least count of micro-ammeter = μ A

Sr. No.	Forward voltage (V_R) (volts)	Forward Current (I_R) (mA)
1		
2		
3		
4		
5		
6		
7		
8		
9		
10		

XII Results

- i) The static resistance of the given diode at a particular point=..... Ω
- ii) The dynamic resistance of the given diode=..... Ω

XIII Interpretation of results

.....

XIV Conclusions and Recommendations

.....

XV Practical Related Questions

Note: Below given are few sample questions for reference. Teachers must design more such questions so as to ensure the achievement of identified CO.

1. Write the ideal value of knee voltage for the diode used.
2. Write the steps to identify the p and n terminals of diode using multimeter.
3. Give reasons for using micro ammeter in a reverse bias mode.

4. State the specifications of diode used in this lab experience.
5. Calculate the current in the given circuit.

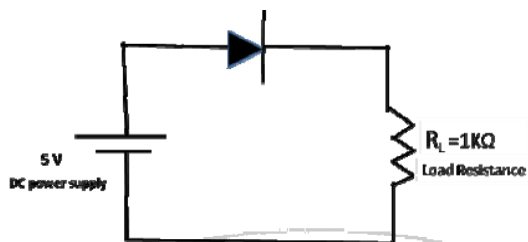

[Space to Write Answers]

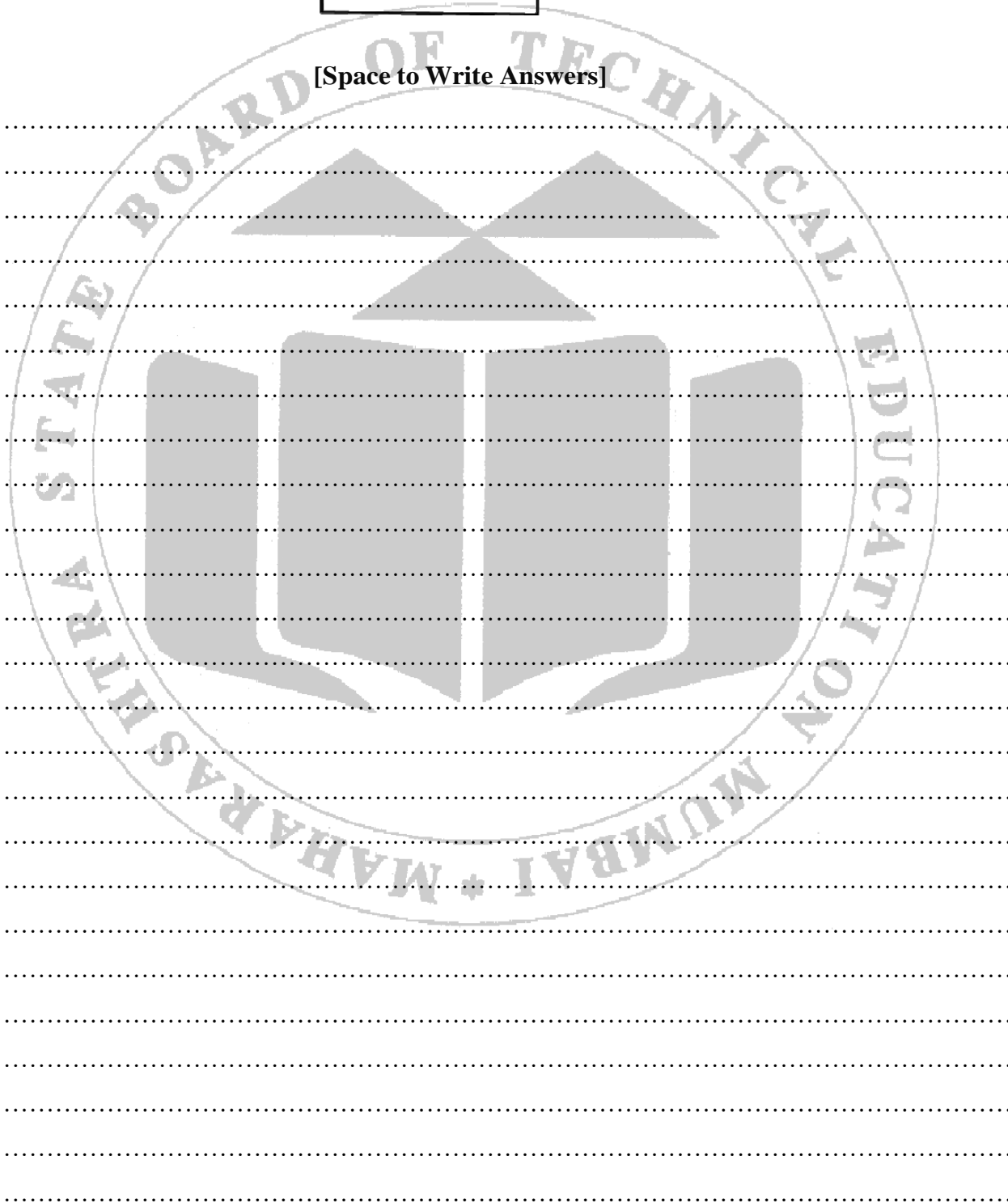

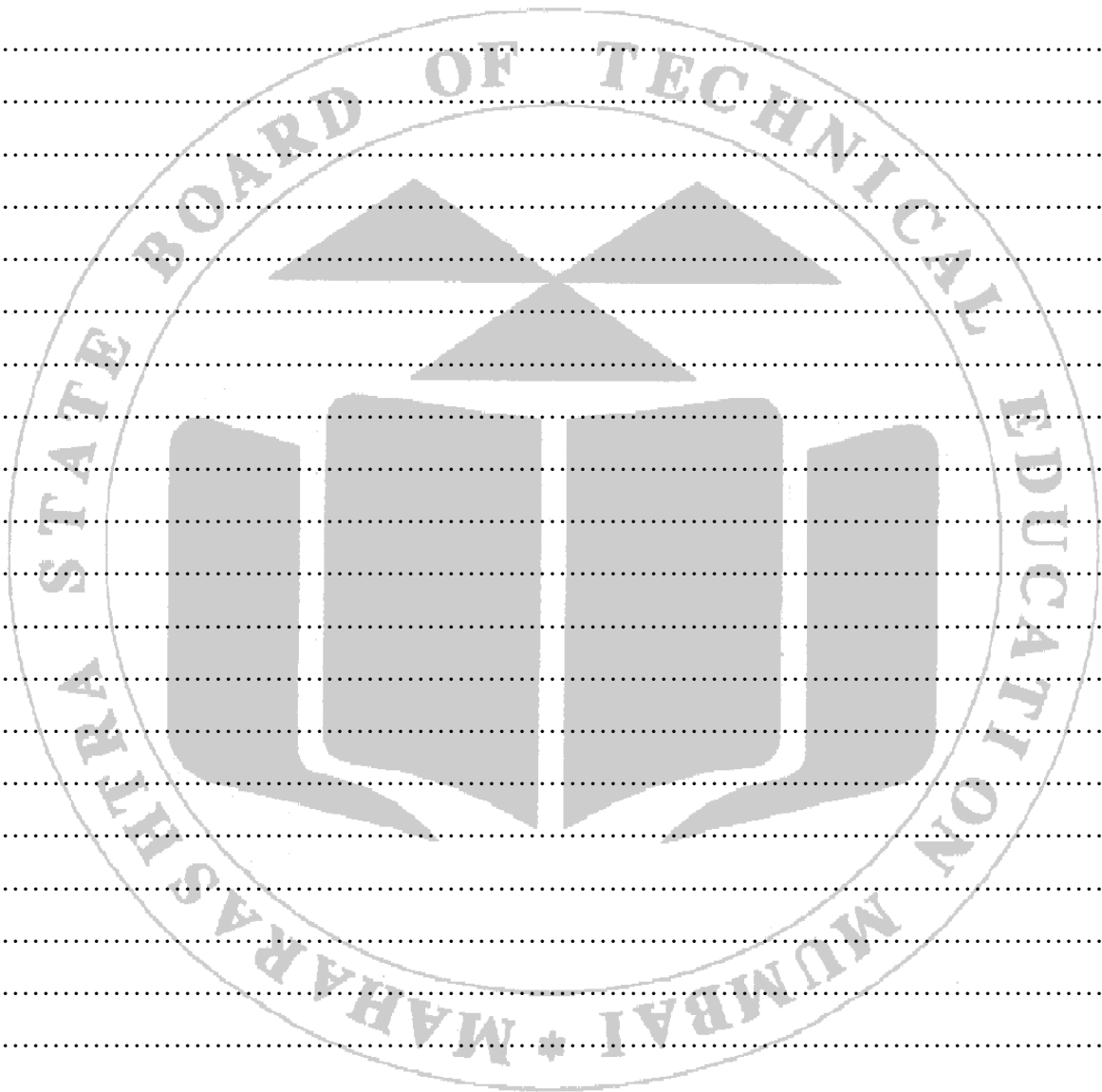

XVI References / Suggestions for further Readings

- a) <https://phet.colorado.edu/en/simulation/semiconductor>
 b) https://youtu.be/wwL4_u8r_u8
 c) <https://youtu.be/RmZ1ZjJtJQ>

XVII Assessment Scheme

Performance indicators		Weightage
Process related: 15 Marks		60%
1.	Handling of the instrument	10
2.	Arrangement of Practical set up	10
3.	Observation & Observation Table	10
4.	Calculation	10
5.	Result	10
6.	Team Spirit	10
Product related: 10 Marks		40%
1.	Timely Submission	10
2.	Interpretation of result	10
3.	Conclusions & Recommendations	10
4.	Practical related questions	10

List of Student Team Members.

1.
2.
3.
4.

Process Related (15)	Marks Obtained		Dated Signature of Faculty
	Product Related (10)	Total (25)	

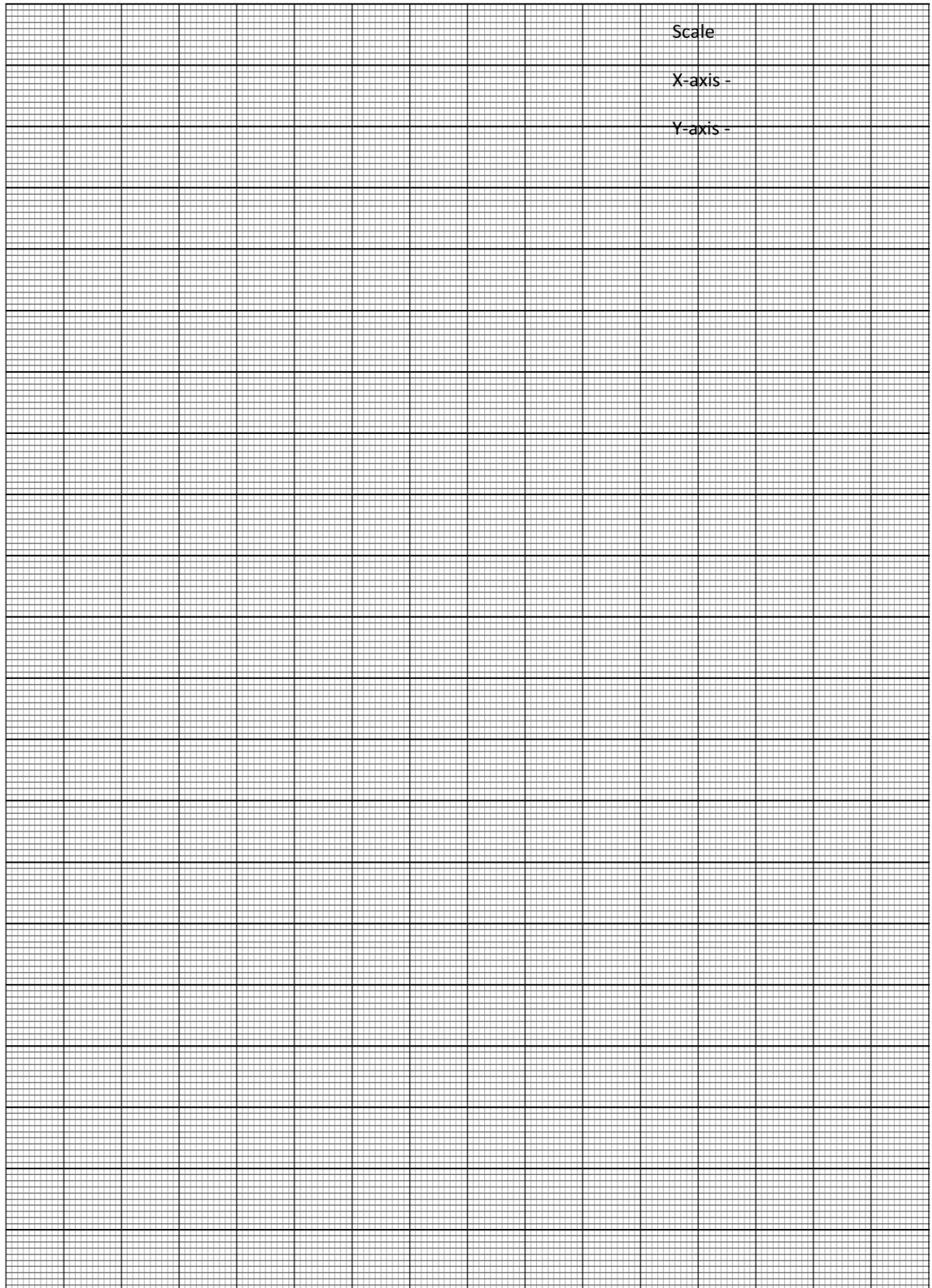

Practical No.9: Determination of forbidden energy band gap in semiconductors

I Practical Significance

Band gap is basically the factor used for determining the conductivity of any metal. Energy band gap differentiates the metals into conductor, insulator, and semiconductor. The electronics industry has seen paradigm shift from the use of triodes, pentodes, and valves to diodes, transistors, semiconductors. The semiconductors are the foundation of modern day electronics such as radio, computers and mobile phones. Semiconductor material is used in the manufacturing of electronic components and used in electronic devices such as transistors and diodes.

II Industry/ Employer Expected Outcome

Apply principles of physics and chemistry to solve broad based relevant engineering Problems.

III Course Level Learning Outcome

Apply the basic principles of electromagnetics to solve given engineering problems.

IV Laboratory Learning Outcome(s)

Determine forbidden energy band gap in semiconductors

V Relevant Affective domain related Outcomes

- a) Handle tools and equipment carefully.
- b) Select instruments of required least count and range.
- c) Following safety measure.

VI Relevant Theoretical Background

Solids can be broadly classified into three groups conductor, semiconductor, insulator. on the basis of their ability to conduct heat and electricity.

Forbidden energy gap(E_g) ;Forbidden energy gap is the energy gap between conduction band and valence band, where no electron is present. In case of conductors, the forbidden energy gap is absent, in case of semiconductors it is of the order of 1eV and in case of insulators, the forbidden energy gap is very large of the order of 6electron volt.

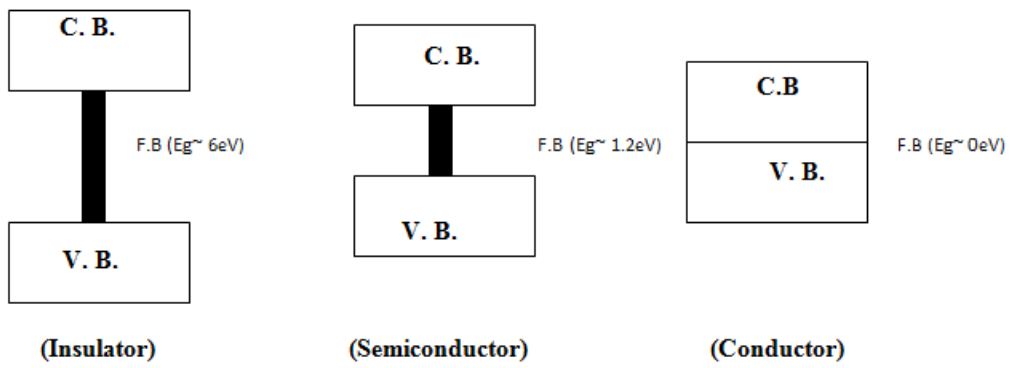

Forbidden Energy Gap is the minimum energy required by electron in valence band to jump into conduction band. Electron in conductor band is free to conduct electricity.

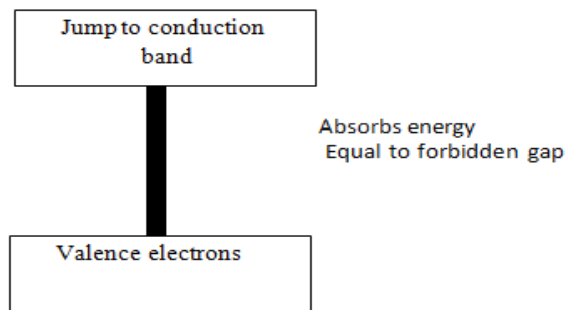

VII Circuit Diagram / Experimental set up / Work Situation.

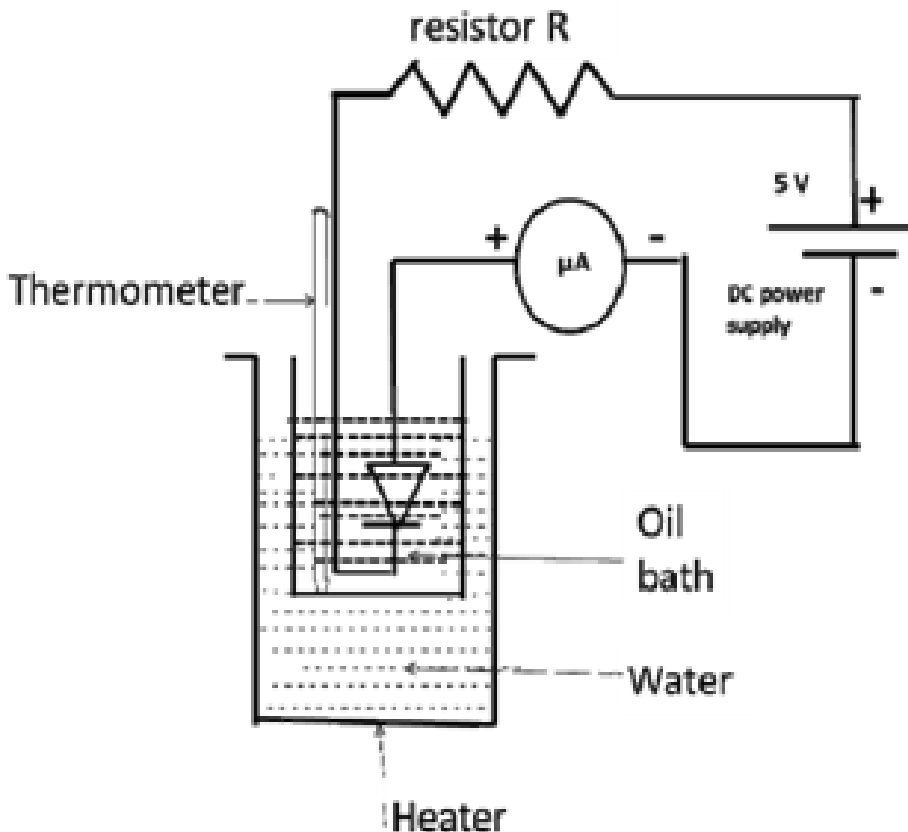

VIII Resources required

Sr.No.	Particulars	Specification	Quantity
1	Beaker	Volume capacity=250 ml	01
2	Test tube		01
3	Thermometer	0 to 100 °C	01
4	Diode	Ge and Si	01
5	Paraffin Oil		200 ml
6	Oil lamp for heating	As available	01
7	Power Supply	0 to 12 V	01

IX Precautions

1. Handle all the equipment's with care.
2. Make connections according to circuit diagram.
3. Get the connections checked by the teacher.
4. Take the readings carefully & the connections should be tight.
5. The maximum temperature should not exceed 95°C
6. Bulb of the thermometer should be inserted well in the oil bath.

X Procedure

1. Connect the circuit as per circuit diagram.
2. Take the oil in the test tube.
3. Put diode and thermometer in test tube.
4. Fill water in the beaker.
5. Arrange the test tube in beaker.
6. Adjust the voltage till the constant saturation current flows through the diode.
7. Heat the water till the temperature reaches to about 70°C.
8. Record the readings of temperatures while cooling at the interval of 5°C.
9. Note corresponding current.
10. Plot a graph of $\log_e I_s$ (on Y-axis) against $1/T$ (on X-axis)
11. Calculate the slope of graph.
12. Calculate forbidden energy gap in joule.
13. Convert it into electron volt (eV)

XI Observations and Calculations

Table: To find absolute temperature and reverse saturation current

Obs. No.	Temp. of Oil bath t ($^{\circ}\text{C}$)	Diode reverse Saturation current I_s μA	Absolute Temperature $T = (t + 273)$ $^{\circ}\text{K}$	(1/T) Per $^{\circ}\text{K}$	$\log_e(I_s)$
1					
2					
3					
4					
5					
6					
7					
8					
9					
10					

Calculations

Diode reverse current is due to the flow of minority carriers. This reverse saturation current (I_s) depends on temperature of semiconductor diode and increases with rise in temperature.

Saturation current is,

$$I_s = CT^3 e^{-E_g/KT}$$

$$\log_e I_s = \log_e CT^3 (E_g/KT)$$

Where, T = Absolute temperature of diode.

K= Boltzmann constant= 1.38×10^{-23} J/K

E_g = Forbidden energy gap. C = constant.

Slope and intercept of line are related as

$$Y = mx + C$$

$$Y \text{ intercept} = \log_e CT^3$$

Forbidden energy Gap= $E_g = \text{slope} \times K$

$$E_g = \text{slope} \times 1.38 \times 10^{-23} \text{ Joule}$$

or

$$E_g = \frac{\text{slope} \times 1.37 \times 10^{-23}}{1.6 \times 10^{-9}} \text{ eV}$$

XII Results

- a) Forbidden Energy gap for (silicon/ germanium) diode=Joule.
- b) Forbidden Energy gap for (silicon/ germanium) diode=eV.

XIII Interpretation of results

- 1. Error in measurement of forbidden energy gap for (silicon/ germanium) diode
- 2. Experimental value-Standard value =eV
Standard value

XIV Conclusions and Recommendations

.....

.....

XV Practical Related Questions

Note: Below given are few sample questions for reference. Teachers must design more such questions so as to ensure the achievement of identified CO.

- 1. The forbidden energy gap for silicon is 1.1eV and for germanium is 0.7eV. Which of the above material will have more conductivity? Give reasons.
- 2. Give reasons for diode immersed in an oil bath.
- 3. Is resistivity of solid depends upon width of forbidden energy gap ?. Give reasons
- 4. Is reverse saturation current dependent upon the change in temperature? Explain.
- 5. Define forbidden energy gap.

[Space to Write Answers]

.....

.....

.....

.....

.....

.....

.....

.....

.....

.....

.....

.....

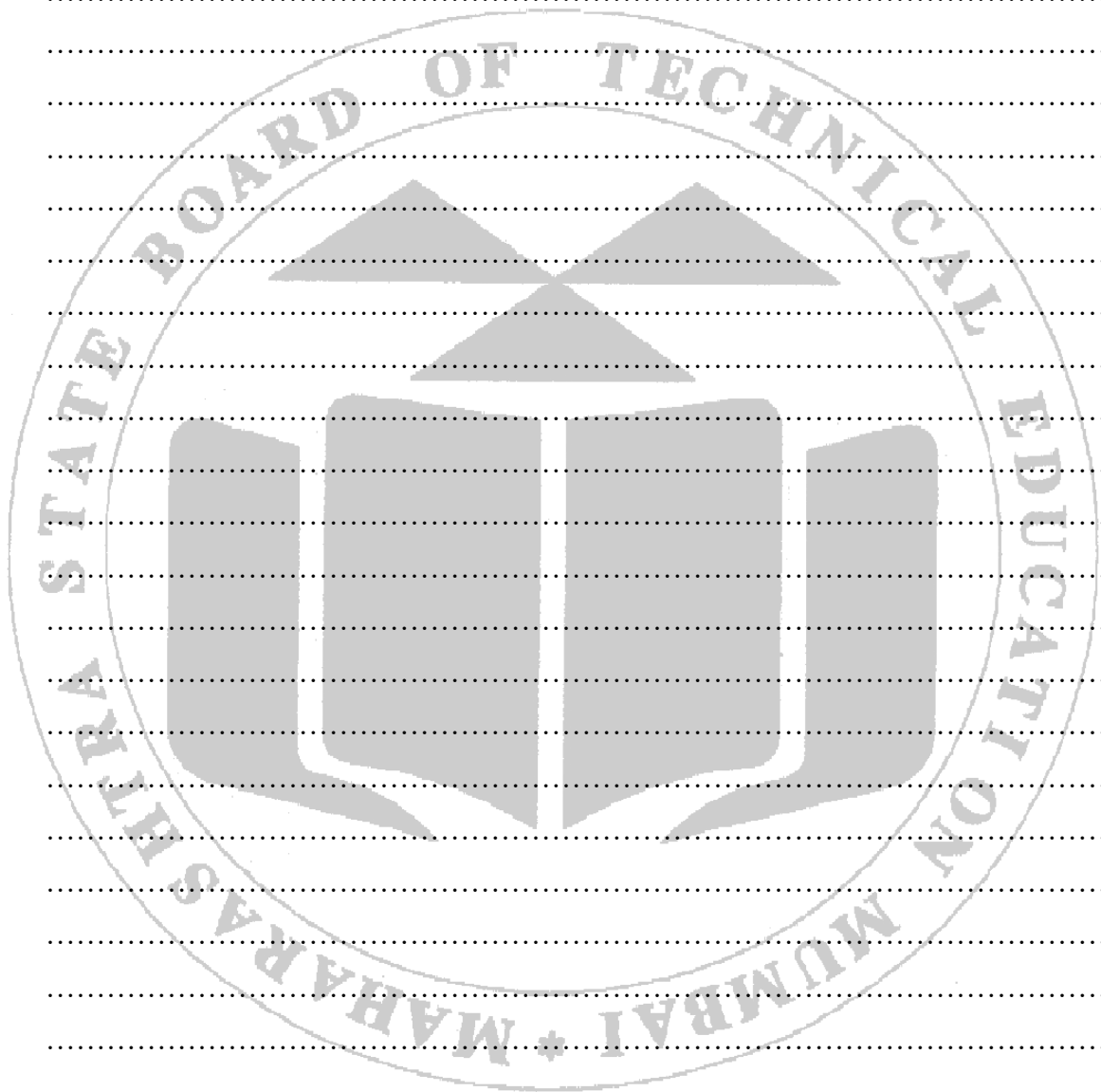

XVI References / Suggestions for further Reading

1. <https://youtu.be/G6OWymqt15Y>
2. <https://youtu.be/h9QIwefSrrI>
3. <https://youtu.be/acYkhB7nM2Y>

XVII Assessment Scheme

Performance indicators		Weightage
Process related: 15 Marks		60%
1.	Selection of the instrument	10
2.	Arrangement of the instrument	10
3.	Connection of circuit diagram	10
4.	Handling of instruments	10
5.	Proper measurement	10
6.	Calculation of parameters concerned	10
Product related: 10 Marks		40%
1.	Accuracy of measurement	10
2.	Interpretation of result	10
3.	Conclusions & Recommendations	10
4.	Practical related questions	10

List of student Team Members

1.
2.
3.
4.

Marks Obtained			Dated Signature of Teacher
Process Related (15)	Product Related (10)	Total (25)	

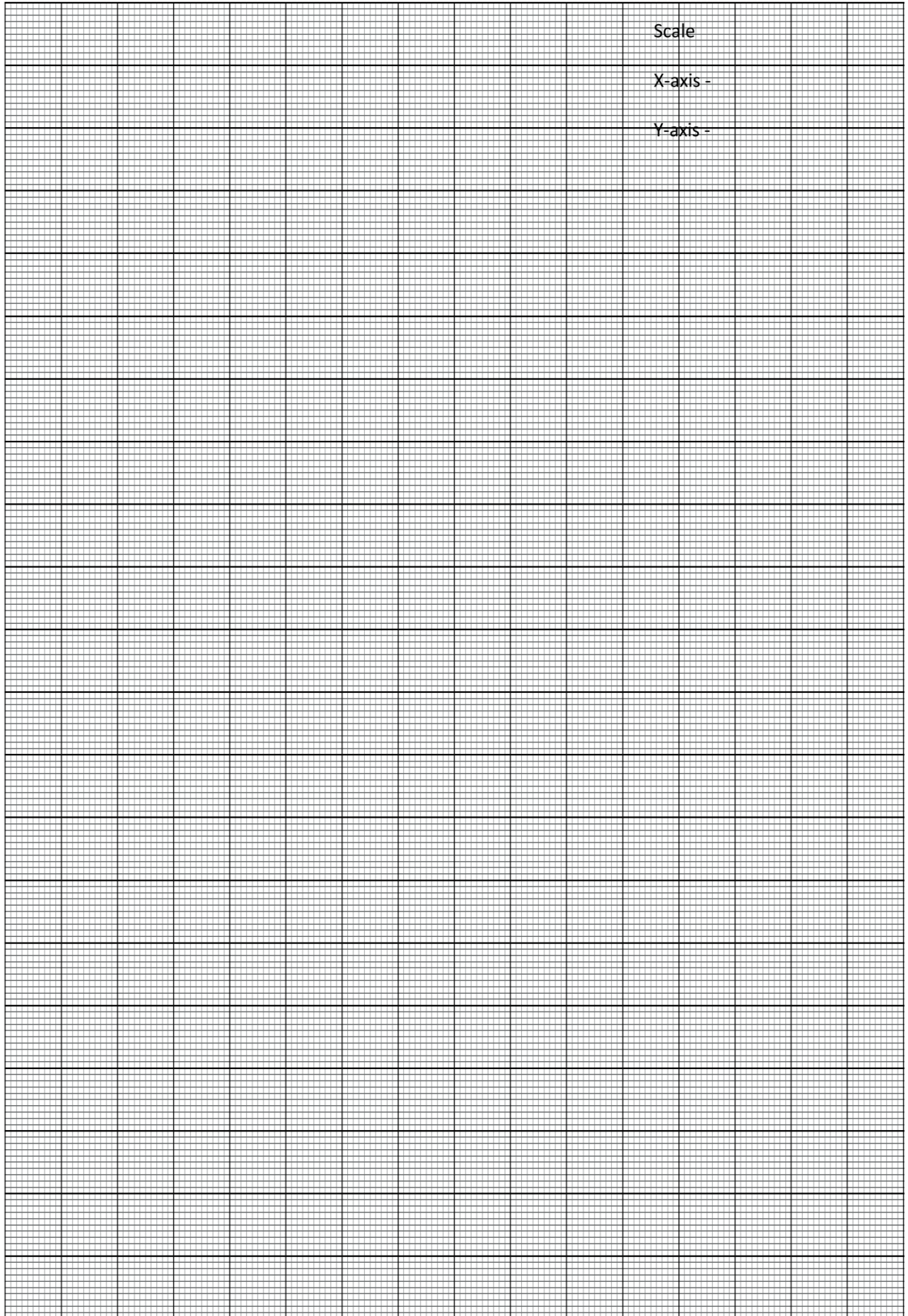

Practical No.10: Determination of Joule's mechanical equivalent of heat by Joule's law.**I Practical Significance**

Turbines used for generation of electricity involve conversion of mechanical energy into electrical energy. Similarly in heat (steam) engine, heat energy is converted into mechanical energy and in electric geysers and heaters, electrical energy is converted into heat energy. The study of conversion of energy from one form into another is vital from engineering point of view. Therefore in this experiment student will analyze one such conversion i.e. conversion of electrical in to heat energy and determine the electrical equivalent of heat energy.

II Industry/ Employer Expected Outcome

Apply principles of physics and chemistry to solve broad based relevant engineering Problems.

III Course Level Learning Outcome

Apply basic principles of thermometry and fibre optics to solve engineering problems.

IV Laboratory Learning Outcome(s)

Use Joule's calorimeter to determine Joule's mechanical equivalent of heat

V Relevant Affective domain related Outcomes

- a) Handle tools and equipments carefully.
- b) Follow the safety measures.

VI Relevant Theoretical Background

Heat is form of energy which flows from higher temperature to lower temperature. When mechanical work and/ electrical work is done, heat is produced. The mechanical energy and electrical energy is related to heat energy by means of proportionality constant. This constant is called "Joule's constant". When electric current is passed through a metal coil, equal amount of heat is generated. In this experiment, the coil is placed in the water in the calorimeter. So as the current passes through the coil, the water in contact with the coil also gets heated. The time for which the current is passed increases, the heat generated also increases.

The electric power is calculated using the formula

$$P=VI,$$

Where, I is the current flowing in the circuit and V is the voltage developed. The relation between work done (W) and electric power (P) is

$$P=W/t.$$

Hence, the work done is calculated using the formula

$$W=VIt.$$

The heat generated in the process is calculated using the formula

$$H = (McSc+MwSw)(\Theta_2- \Theta_1)$$

Where,

- M_c - Mass of copper calorimeter
- M_w - Mass of water in calorimeter
- S_c - Specific heat of copper calorimeter=0.1 Kcal/Kg 0c

- S_w - Specific heat of water = 1 Kcal/Kg $^{\circ}C$
 - Θ_1 - Initial temperature water
 - Θ_2 - Final temperature of water
- and Work done (W) is directly proportional to the heat produced (H).

$W \propto H$

$W = JH$ where J is Mechanical equivalent of heat.

$J = W/H$

VII Circuit Diagram / Experimental set up / Work Situation.

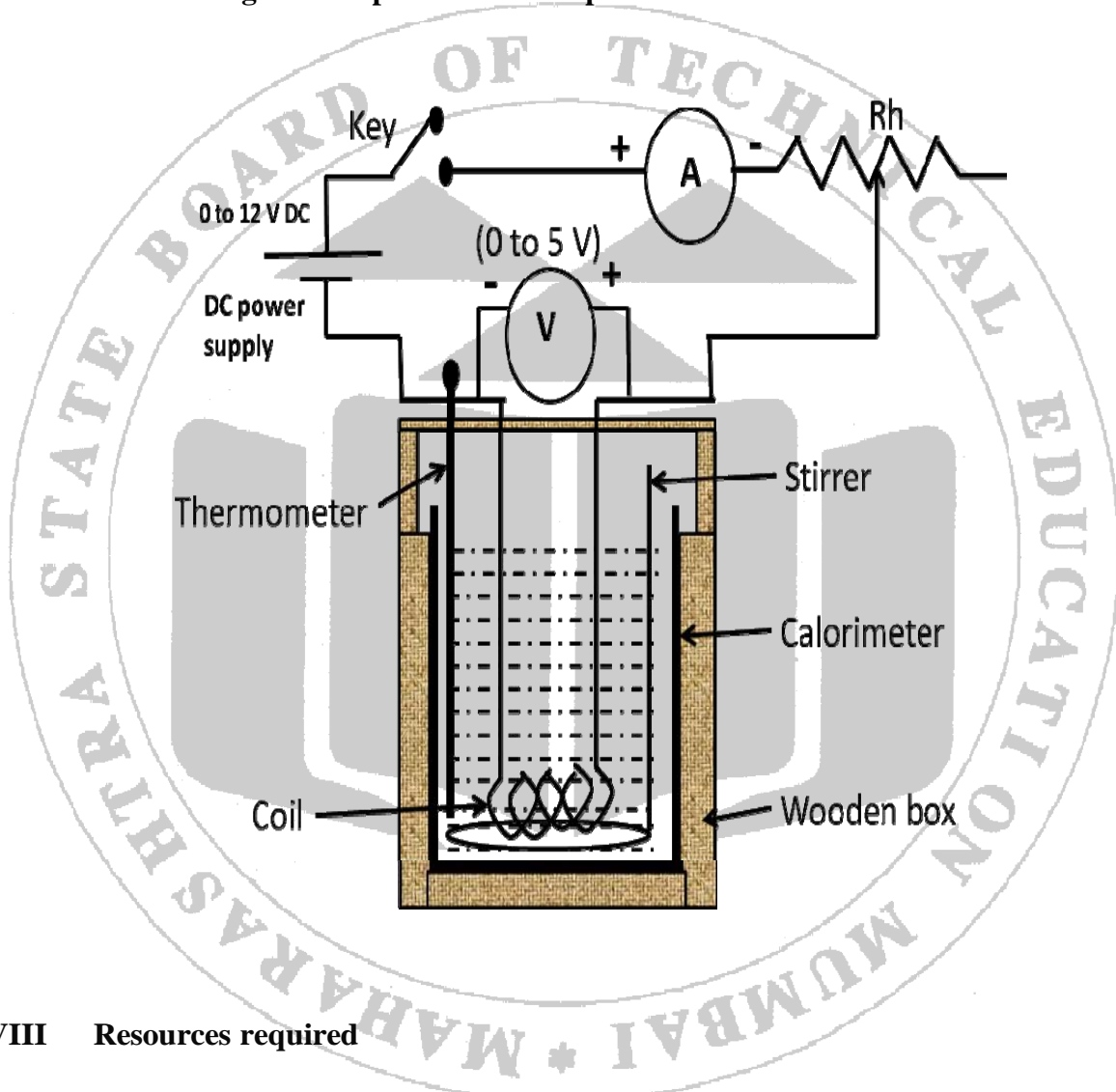

VIII Resources required

Sr. No.	Instrument	Specification	Quantity
1	Voltmeter	(0-5V); L.C.=0.1 V	1
2	Ammeter	(0-5A); L.C.=0.1 A	1
3	Plug key		1
4	Rheostat	Range=300 Ω	1
5	DC power supply	0-12 V, 1Amp	1

6	Joule's calorimeter with stirrer encased in wooden box		1
7	Thermometer	Least count= 0.5°C	1
8	Connecting wires		

IX Precautions

1. Connections should be tight.
2. Weigh the calorimeter and water taken accurately.
3. Continuously stir the water throughout the experiment.

X Procedure

1. Record the least count and range of ammeter, voltmeter and thermometer .
2. Weigh the calorimeter.
3. Take required amount of water in the calorimeter.
4. Connect the circuit as shown in Fig.01.
5. Note down the initial temperature (Θ_1) of water.
6. Switch on the DC supply.
7. Adjust the current (I) to a desired value (say I=1.5A) using rheostat.
8. Note down the corresponding voltage (V).
9. Switch off the DC supply.
10. Switch on the DC supply and stop watch simultaneously.
11. Note the temperature (Θ_2) of water at regular interval of 300 second.
12. In order to have uniform distribution of heat, stir the water continuously Through out the experiment.
13. Calculate the work done $W=VIt$ in Joules.
14. Calculate heat generated $H=(M_c S_c + M_w S_w)(\Theta_2 - \Theta_1)$ in Kcal.
15. Find Joule's constant (mechanical equivalent of heat) $J = \frac{W}{H}$
16. Plot the graph of W Vs H.
17. Find the slope of this graph.
18. Calculate the value of Joule's constant by slope of the graph.

XI Observations and Calculations

1. Least count of ammeter =.....
2. Range of ammeter=.....
3. Least count of voltmeter=.....
4. Range of voltmeter=.....
5. Least count of thermometer=... ..
6. Mass of copper calorimeter= Mc
7. Mass of water in calorimeter=..... Mw

8. Specific heat of copper calorimeter= $S_c=0.1$ Kcal/Kg 0c
9. Specific heat of water= $S_w=1$ Kcal/Kg 0C
10. Initial temperature of water= $\Theta_1=.....$
11. Current flowing in the circuit= $.....$
12. Voltage developed= $V=.....$

Sr. No.	Time for which current is passed(t sec)	Temperature of water (Θ_2 0C)	Work done $W=VIt$ (J)	Heat generated $H=(M_cS_c+M_wS_w) (\Theta_2-\Theta_1)$ (Kcal)	Joule's constant $J=\frac{W}{H}$ (J/Kcal)
1	300				
2	600				
3	900				
4	1200				
5	1500				
6	1800				
Mean					J=

XII Results

Value of J by experiment (in J/Kcal)	Value of J by graph (in J/Kcal)	Theoretical value of J under ideal conditions(in J/Kcal)
		4186

XIII Interpretation of results

Error in the experimental value of J= Theoretical value of J under ideal conditions - Value of J by experiment

XIV Conclusions and Recommendations

.....

.....

.....

.....

XV Practical Related Questions

Note: Below given are few sample questions for reference. Teachers must design more such questions so as to ensure the achievement of identified CO.

1. Will there be any change in amount of heat produced, if direction of current is changed. Give reasons for your answer.
2. The work done 5000 J is equivalent to how many kcal?
3. If amount of current passed through coil is doubled, determine the corresponding change in the heat produced.
4. Is there any change in amount of heat produced if heating element of coil is replaced by Copper (keeping the current constant). Give reasons.
5. State & explain Joule's law.

[Space to Write Answers]

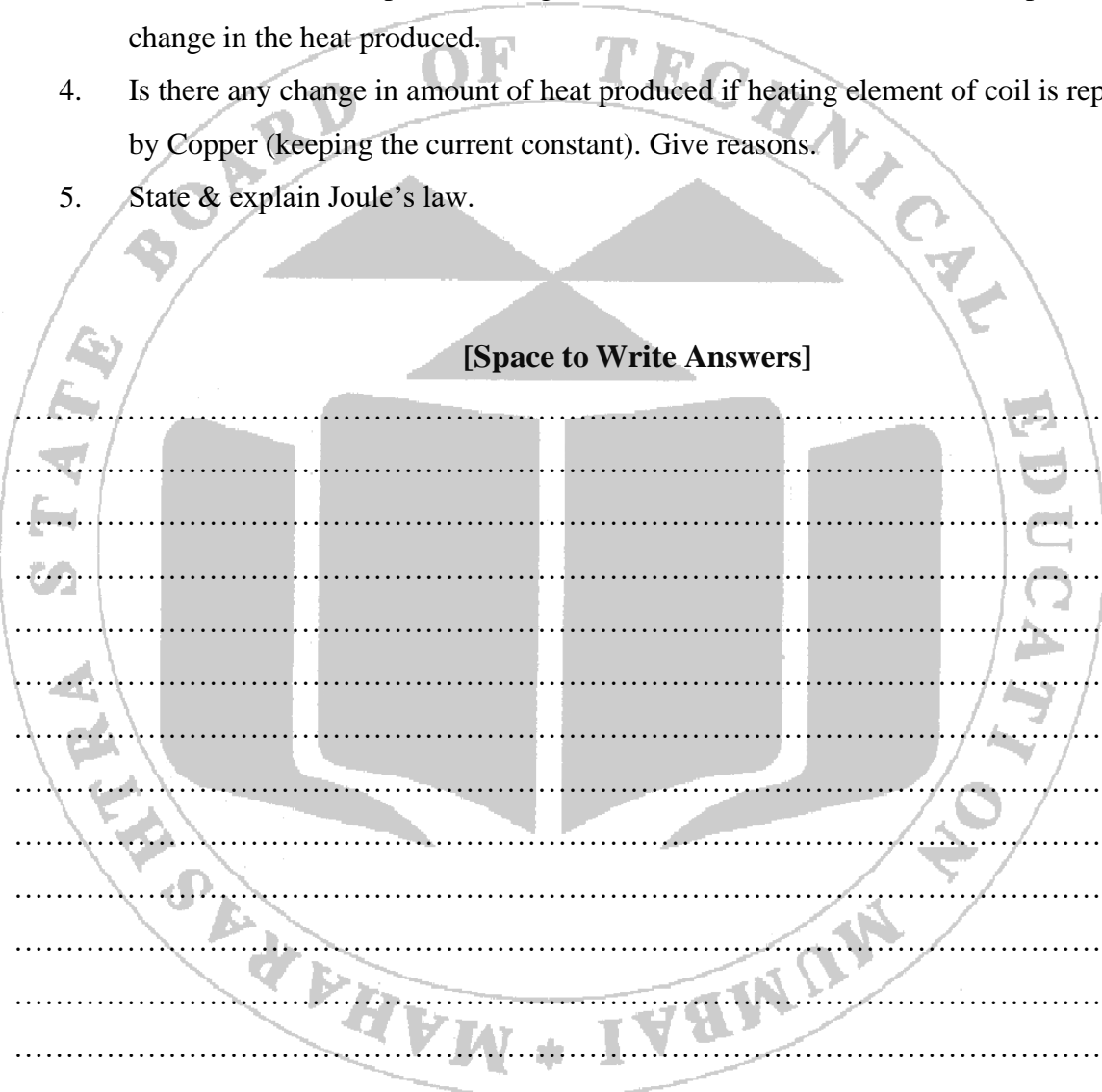

A large watermark of the Maharashtra State Board of Technical Education logo is centered on the page. The logo is circular and contains a stylized book with a lamp on top. The text 'MAHARASHTRA STATE BOARD OF TECHNICAL EDUCATION MUMBAI' is written around the perimeter of the circle. Below the watermark, there are several horizontal dotted lines for writing answers.

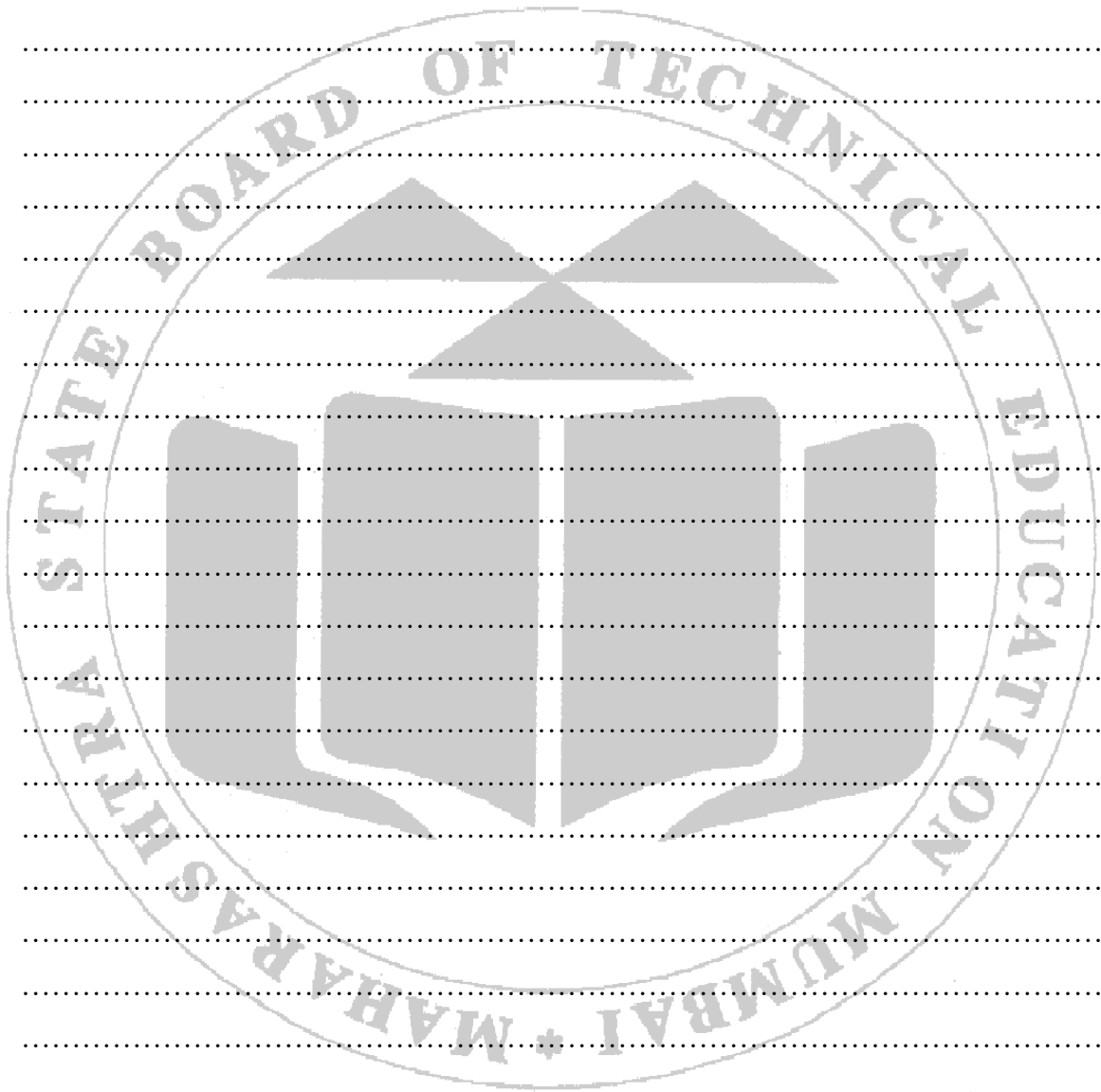

XVI References / Suggestions for further Reading

1. <https://www.youtube.com/watch?v=yjOcbjpTCFA>
2. <https://youtu.be/oQt-5Wg-AxQ>
3. <https://youtu.be/XpSHdxGaWvs>

XVII Assessment Scheme

Performance indicators		Weightage
Process related: 15 Marks		60%
1.	Selection of the instrument	10
2.	Arrangement of the instrument	10
3.	Connection of circuit diagram	10
4.	Handling of instruments	10
5.	Proper measurement	10
6.	Calculation of parameters concerned	10
Product related: 10 Marks		40%
1.	Accuracy of measurement	10
2.	Interpretation of result	10
3.	Conclusions & Recommendations	10
4.	Practical related questions	10

List of Student Team Members.

1.
2.
3.
4.

Marks Obtained			Dated Signature of Faculty
Process Related (15)	Product Related (10)	Total (25)	

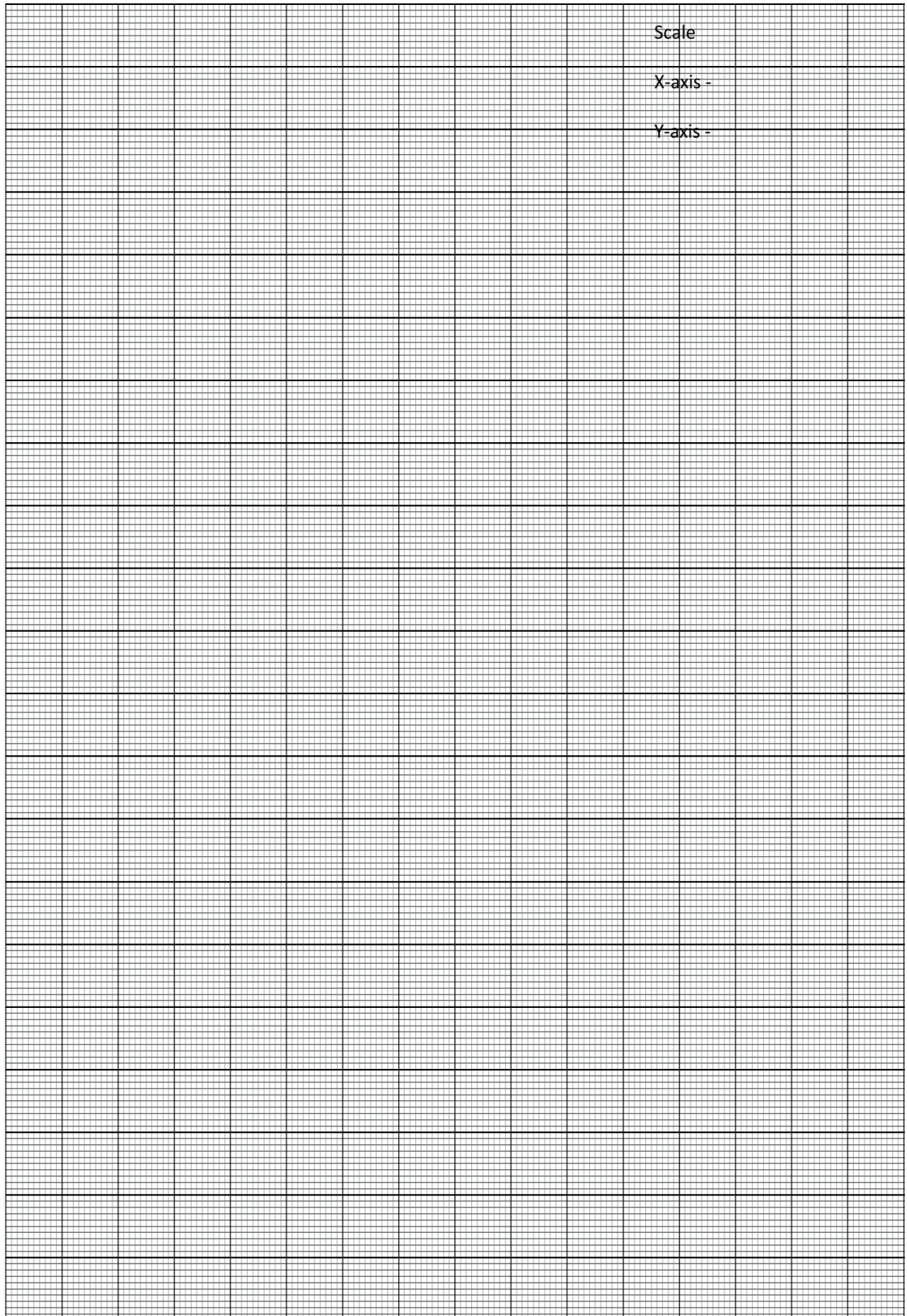

Practical No.11 Determination of pressure-volume relation using Boyle's law

I Practical Significance

Various engineering applications such as vehicle tyres , aerosols cans, steam engines and combustion engines works on the principle of Boyle's law of Gases. Many fuel gases are stored under high pressure to occupy smaller volume. In this experiment student determines the relation between the change in pressure and volume of gas.

II Industry/ Employer Expected Outcome

Apply principles of physics and chemistry to solve broad based relevant engineering Problems.

III Course Level Learning Outcome

Apply basic principles of thermometry and fibre optics to solve engineering problems.

IV Laboratory Learning Outcome(s)

Determine the pressure-volume relation using Boyle's law

V Relevant Affective domain related Outcomes

- a) Handling instrument carefully.
- b) Practice good housekeeping.
- c) Demonstrate working as a team member.

VI Relevant Theoretical Background

Gas is a state of matter that has no fixed shape and no fixed volume. Gases have lower density than other states of matter, such as solids and liquids. When more gas particles enter a container, there is less space for the particles to spread out, and they become compressed. The particles exert more force on the interior volume of the container. This force is called pressure. Temperature, pressure, and volume of a gas are interdependent, and many scientists have developed laws to describe the relationships among them. These variables of gases are related with each other and magnitude of these variables or properties will determine the state of gas.

According to Boyle's law, at constant temperature and for a fixed mass of gas, absolute pressure of the gas is inversely proportional to volume of gas. If absolute pressure of the gas is P and volume of the gas is V , at constant temperature and for a fixed mass of gas, we will have following relationship between absolute pressure P and volume V It could also be defined as product of pressure and volume will be constant for a gas of fixed mass and constant temperature.

$$P \propto \frac{1}{V} \text{ at constant temperature} \quad \text{or} \quad P \times V = \text{constant}$$

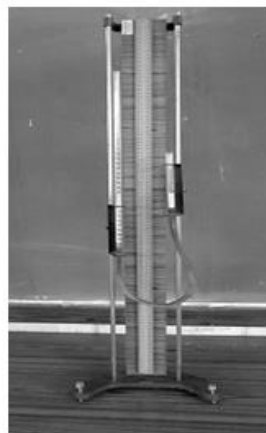
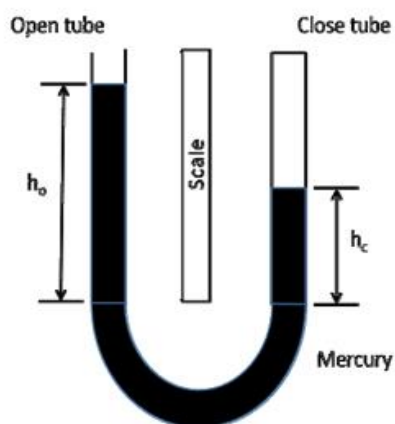
VII Circuit Diagram / Experimental set up / Work Situation.**VIII Resources required**

Sr. No.	Particulars	Specifications	Quantity
1	Barometer	Simple mercury barometer	01
2	Boyle's law apparatus		01
3	Spirit level	Standard	01
4	Mercury		1.25kg
5	Thermometer	0 to 100°C	01

IX Precautions

- Keep eye position in the level with the Mercury Meniscus while taking observations.
- Handle the apparatus carefully as mercury is poisonous.

X Procedure

- Find atmospheric pressure using Barometer.
- Set up the Boyle's Law experiment apparatus by using spirit level.
- Adjust the height of mercury in open and closed tube at the same level.
- Note down,
 - Volume of air in closed tube V .
 - Height of Hg in closed tube h_c .
 - Height of Hg in open tube h_o .
 - Find $h = h_o - h_c$
- Keep close tube at constant height.
- Change the height of open tube in upward direction.

7. Note down,
 - a. Volume of air in closed tube V.
 - b. Height of Hg in closed tube h_c ,
 - c. Height of Hg in open tube h_0 .
 - d. Find $h = h_0 - h_c$
8. Repeat step 06 and 07 for two times.
9. Repeat step 06 and 07 for downward direction.
10. Calculate pressure P for each reading.
11. Calculate $P \times V$ for each reading.
12. Calculate mean value of $P \times V$.
13. Plot a graph of P against $\frac{1}{V}$.
14. Calculate the slope of graph.

XI Observations and Calculations

1. Atmospheric pressure (H) = cm of Hg
2. Room temperature = °C

Sr. No.	Volume enclosed air V cm ³	1/V 1/cm ³	Height of Hg		h = h ₀ - h _c cm	P = H + h cm of Hg	P x V
			in closed tube h _c cm	in open tube h ₀ cm			
1							
2							
3							
4							
5							
6							
7							
Mean (P x V)							

Calculations

1. $V_1 = \dots\dots\dots$ c.c.
2. $1/V_1 = \dots\dots\dots$ per c.c.
3. $h_c = \dots\dots\dots$ cm of Hg
4. $h_0 = \dots\dots\dots$ cm of Hg

5. $h = h_0 - hc = \dots\dots\dots$ cm of Hg
6. $P_1 = H + h = \dots\dots\dots$ cm of Hg
7. $P_1V_1 = P_2V_2$

Graph:

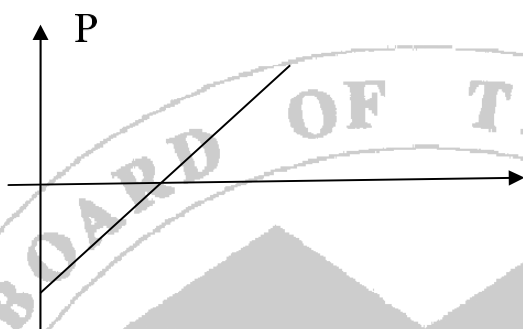

XII Results

- a) $P \times V = \dots\dots\dots$ By calculation.
- b) $P \times V = \dots\dots\dots$ By graph.

XIII Interpretation of results

.....

.....

.....

XIV Conclusions and Recommendations

.....

.....

XV Practical Related Questions

Note: Below given are few sample questions for reference. Teachers must design more such questions so as to ensure the achievement of identified CO.

1. State new volume of the gas if the pressure on 350 cm³ of oxygen at 720 mm Hg is decreased to 600 mm Hg?
2. Can we measure the atmospheric pressure using Boyle's law apparatus?
3. Give the name of gas enclosed in closed tube.
4. State the Boyle's law.
5. Write two examples of Boyle's law.

[Space to Write Answers]

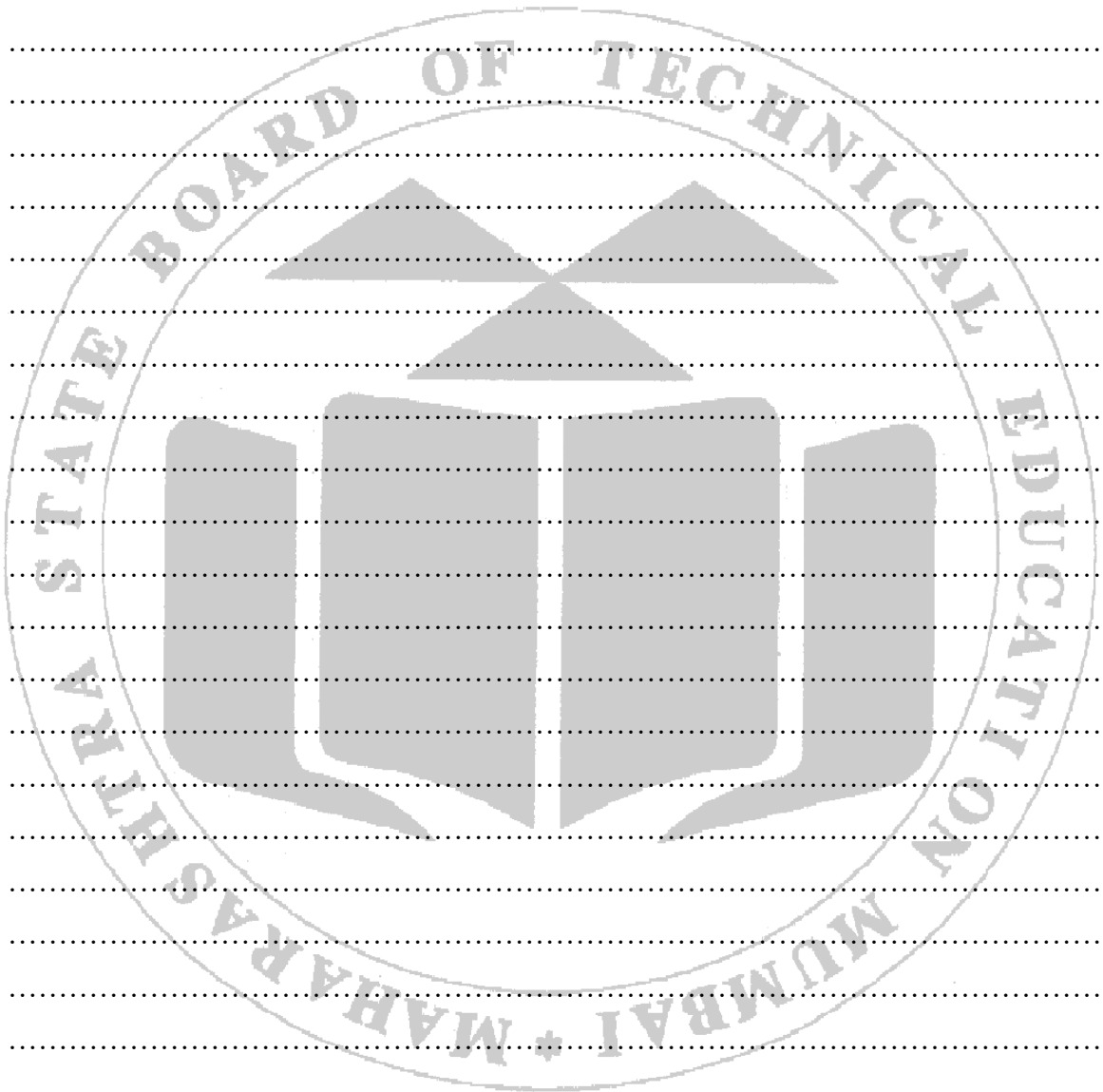



XVI References / Suggestions for further Readings

- a) <https://youtu.be/YQmv272-4yU?si=Jc4oyUcNeo-DUc6B>
 b) <https://youtu.be/e1iuC2kHJdo>
 c) https://youtu.be/7eNGWUEsAB4?si=y6_2gwkv_ycPcG-W

XVII Assessment Scheme

Performance indicators		Weightage
Process related: 15 Marks		60%
1.	Arrangement of apparatus	20
2.	Measurement of heights	20
3.	Calculations	10
4.	Involvement in experiment	10
Product related: 10 Marks		40%
1.	Accuracy of measurement	10
2.	Interpretation from graph	10
3.	Conclusions & Recommendations	10
4.	Practical related questions	10

List of Student Team Members.

1.
 2.
 3.
 4.

Marks Obtained			Dated Signature of Faculty
Process Related (15)	Product Related (10)	Total (25)	

Practical No.12: Determination of the rate of heat loss due to convection by Newton's law of cooling.

I Practical Significance

The rate of heat loss from a body is directly proportional to the difference in the temperature of the body & its surroundings, given that the temperature is not large.' This law is used to explain, why hot water or milk left on a table cools faster than a little warm milk or water left on the table. Newton's law of cooling helps us to feel the temperature of anybody without actually measuring it, given the initial temperature of the body and the temperature of the surrounding. It helps to determine the temperature of a drink in a refrigerator after a particular length of time has passed. It helps to indicate the time of death by looking at the possible body temperature at the time of death and the current body temperature.

II Industry/ Employer Expected Outcome

Apply principles of physics and chemistry to solve broad based relevant engineering Problems.

III Course Level Learning Outcome

Apply basic principles of thermometry and fibre optics to solve engineering problems.

IV Laboratory Learning Outcome(s)

Use Newton's law of cooling to determine the rate of heat loss due to convection phenomena

V Relevant Affective domain related Outcomes

- a) Handling instrument carefully.
- b) Practice good housekeeping.
- c) Demonstrate working as a team member

VI Relevant Theoretical Background

According to the Newton law of cooling formula, the amount of heat dissipation of a body is proportional to the temperature differential between both the system and its surroundings. The rule is typically tempered by the requirement that the difference in temperature is modest and the characteristics of the heat transmission process remain unchanged. Simply put, it is comparable to saying that the coefficient of heat transfer, which controls temperature variations as well as the level of heat dissipation, is fixed. This criterion is frequently satisfied in heat conduction because most substances' thermal conductivity is just slightly temperature-dependent. Newton was the one to conduct a systematic analysis of the link between a certain body's heat loss in a specific enclosure with its temperature.

- Newton's law of cooling formula describes the pace at which an item or object's temperature decreases if subjected to radiation.
- Considering that the temperature gradient between the item and its settings is fairly modest, this variation is directly proportional to it.

- The Newton law of cooling formula states that the heat loss rate, $-dQ/dt$ of the body, is exactly related to the temperature differential between the body and its settings, $\Delta T = (T_2 - T_1)$.
- The rule applies only to minor temperature variations. Moreover, the quantity of heat dissipated by radiation is regulated by the surface structure of the body as well as the area of the exterior surface.
- As a result, the phrase may be written as

$$-dQ/dt = k(T_2 - T_1)$$

$T(t)$ – the temperature of the body at the time ‘t’

T_s – surrounding temperature

T_0 – initial temperature

t – time

k – proportionality constant

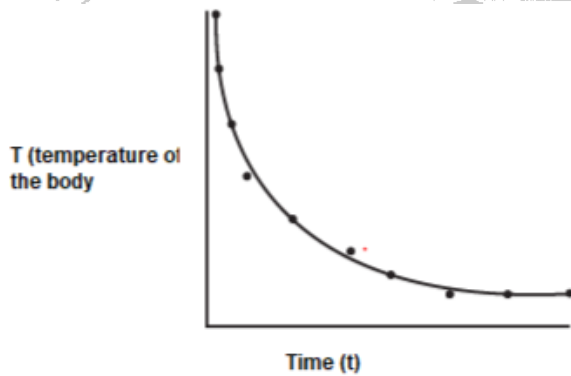

VII Circuit Diagram / Experimental set up / Work Situation.

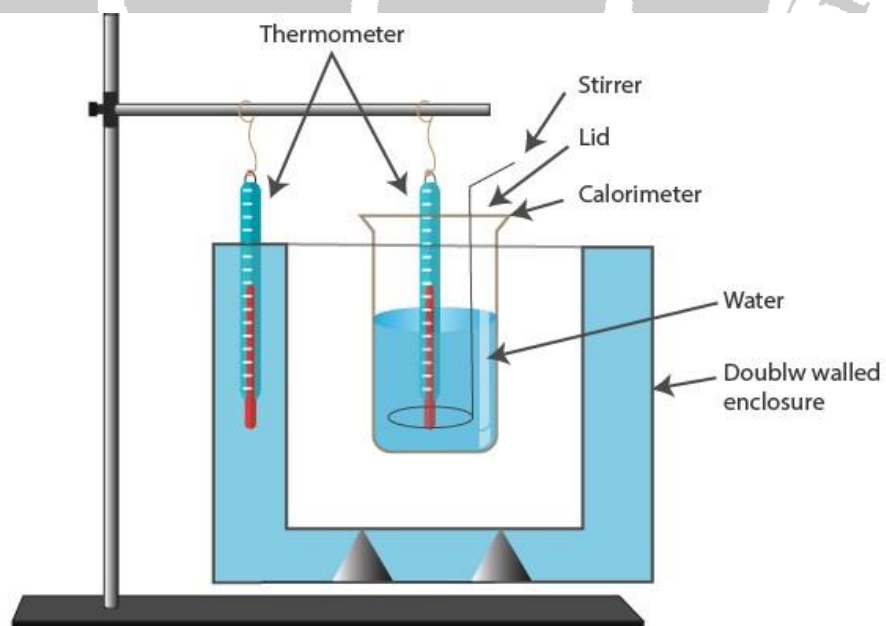

Newton's law of cooling apparatus

VIII Resources required

Sr. No.	Particulars	Specification	Quantity
1	Thermometer		1
2	Stirrer		1
3	Calorimeter		1
4	Large metal Box		1

IX Precautions

1. Temperature should be noted at steady state temperature.
2. Insulation jacket must be efficient to reduce loss of heat due to radiation

X Procedure

1. Clean and dry the calorimeter and weigh it empty with the stirrer only.
2. Heat some water in two separate identical calorimeters to about 70-75°C and place them in a double walled chamber.
3. Place the calorimeter lids and insert a thermometer into each calorimeter.
4. Gently stir the water and note the temperatures of both the thermometers at an interval of one minute. Go on doing this till the temperatures fall to about 50°C above the room temperature.
5. Now cool the calorimeters to room temperature and weigh them again. Hence determine the mass of water Plot the two cooling curves- one for water on the same piece of graph paper with time as the abscissa and temperature as the ordinate.
6. From the curves, determine the time taken by the water to cool through the same range of temperature which should be about 200 °C.

XI Observations and Calculations

1. Least count of thermometer = °C
2. Least count of stopwatch = Sec
3. Initial temperature of water in the enclosure $\Theta_1 = \dots\dots\dots$ °C
4. Final temperature of water in the enclosure $\Theta_2 = \dots\dots\dots$ °C

Sr. No.	Time (min)	Temperature of water in calorimeter (°C)	Sr. No.	Time (min)	Temperature of water in calorimeter (°C)
1			11		
2			12		
3			13		
4			14		
5			15		
6			16		
7			17		
8			18		
9			19		
10			20		

XII Interpretation of results

The nature of Newton’s law of cooling is.....

XIII Conclusions and Recommendations

.....

XIV Practical Related Questions

1. State the Newton’s law of cooling.
2. Name the three modes of transfer of heat.
3. What is convection?
4. Write the examples of radiation
5. Thermos is the example of which mode of transfer of heat?

[Space to Write Answers]

.....

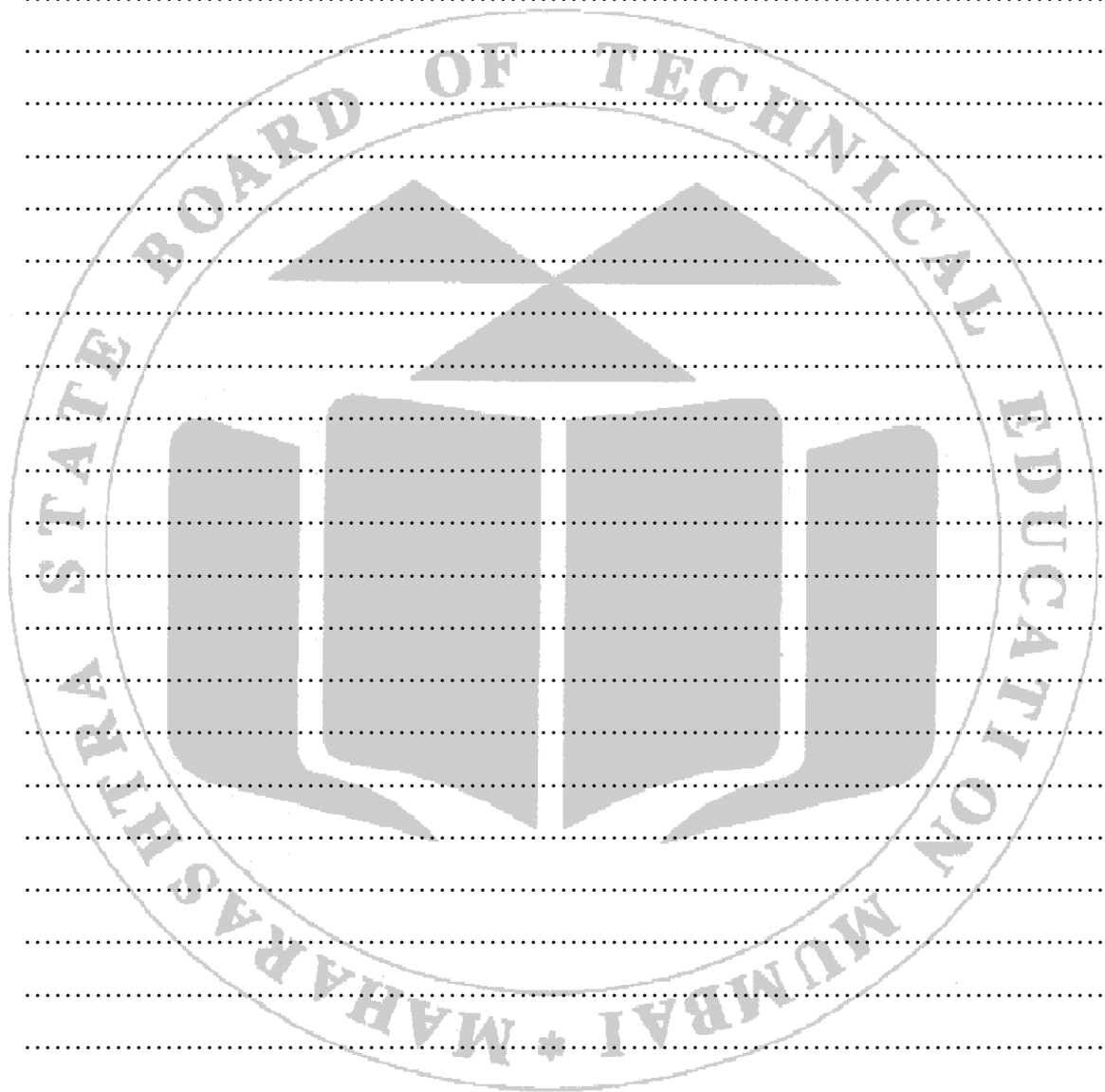

XV References / Suggestions for further Readings

- <https://youtu.be/ORSZdpbxPHg?si=vsSHBZJBZbxrFXBJ>
- <https://vlab.amrita.edu/index.php?brch=194&cnt=1&sim=354&sub=1>
- <https://youtu.be/tc2PboiqEI8>

XVI Assessment Scheme

Performance indicators		Weightage
Process related: 15 Marks		60%
1.	Arrangement of apparatus	20
2.	Measurement of heights	20
3.	Calculations	10
4.	Involvement in experiment	10
Product related: 10 Marks		40%
1.	Accuracy of measurement	10
2.	Interpretation from graph	10
3.	Conclusions & Recommendations	10
4.	Practical related questions	10

List of Student Team Members.

-
-
-
-

Marks Obtained			Dated Signature of Faculty
Process Related (15)	Product Related (10)	Total (25)	

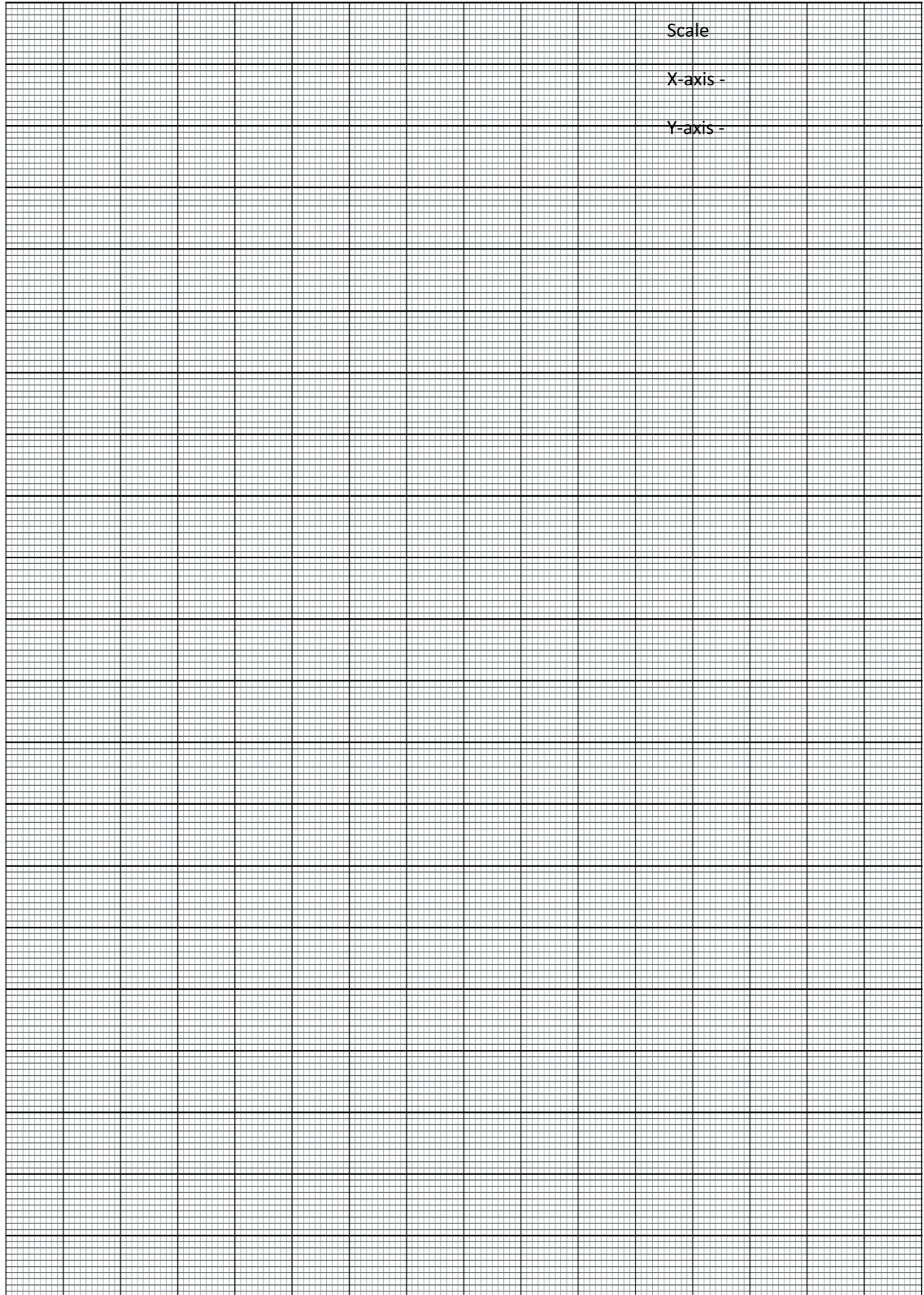

Practical No. 13 Determination of Coefficient of thermal conductivity.

I Practical Significance

Materials of high thermal conductivity are widely used in heat sink applications and materials of low thermal conductivity are used as thermal insulation. In this experiment student will measure the thermal conductivity of a material by using Searle's apparatus.

II Industry/ Employer Expected Outcome

Apply principles of physics and chemistry to solve broad based relevant engineering Problems.

III Course Level Learning Outcome

Apply basic principles of thermometry and fibre optics to solve engineering problems.

IV Laboratory Learning Outcome(s)

Use Searle's thermal conductivity apparatus to find coefficient of thermal conductivity of given material (Virtual Lab)

V Relevant Affective domain related Outcomes

- a) Handling instrument carefully.
- b) Practice good housekeeping.

VI Relevant Theoretical Background

Steady state of temperature is a state where the amount of heat in a slab is constant. Temperature gradient is defined as the change in temperature per unit change in distance. Its SI unit is $OKJm$.

Coefficient of thermal conductivity (K) is defined as the quantity of heat which flows in one second through a slab of given material of unit thickness and unit area of cross- section when its opposite faces are maintained at a temperature difference of $1^{\circ}C$.

Formula used:

$$K = \frac{m \times s \times (\theta_3 - \theta_4)}{A \times (\theta_2 - \theta_1) \times t}$$

'm' is the mass of water, 's' is specific heat of water, 't' is the time of flow of water in steady state, 'A' is the area of cross section of copper rod, 'd' is the distance between the thermometer T₁ and T₂ and $\theta_1, \theta_2, \theta_3, \theta_4$ are the temperatures of thermometer T₁, T₂, T₃ and T₄ respectively (Fig.01).

VII Circuit Diagram / Experimental set up / Work Situation.

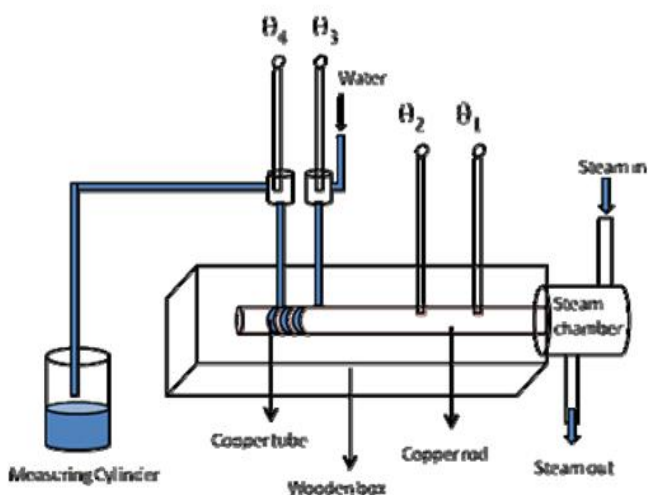

VIII Resources required

Sr.No.	Particulars	Specification	Quantity
1	Searle's apparatus	length of rod 50cm	01
2	Steam chamber		01
3	Measuring cylinder	500ml	01
4	Stop watch	LC 0.1sec	01
5	Electric heater	750watt	01

IX Precautions

1. Temperature should be noted at steady state temperature.
2. Insulation jacket must be efficient to reduce loss of heat due to radiation
3. Flow of water circulated through tube should be slow and uniform.
4. The gas cylinder burner is keep in off mode when the experiment is completed
5. Be sure that the steady state is reached before taking the final reading.

X Procedure

1. Measure the radius of the metallic rod using a Vernier caliper and hence determine the area of the rod.

2. Measure the distance between thermometers T1 and T2 mounted on rod using meter scale.
3. Mount the thermometers T3 and T4 as shown in Fig.01.
4. Pass steam through the steam chamber.
5. Connect copper tubing wound round on the right end of metal rod to constant pressure head.
6. Adjust the top and punch cock such that water flows at steady rate.
7. Collect the water leaving the copper tube for known time (5 minutes).
8. Measures the volume of water collected with the help of measuring cylinder
9. Finds the mass of water collected.
10. Record the steady state temperatures θ_1 , θ_2 , θ_3 , and θ_4 from the thermometers T1, T2, T3 and T4 respectively.
11. Calculate the coefficient of thermal conductivity (K) of given material of rod using given formula.

XI Observations and Calculations

1. Material of rod =
2. Length of the rod= cm
3. Area of cross section of the rod = cm² =..... m²

Diameter (D) at different points	MSR (cm)	CSD	CSR = CSD × LC (cm)	TR = MSR + CSR (cm)	CR = TR ± (z) (cm)	Average reading D (cm)	Radius of rod (D/2) (cm)	Area of Cross-section A = πr ² (cm ²)
1								
2								
3								

4. Distance between thermometers T₁ and T₂ = d = cm = m
5. At steady state,
 - θ_1 = °C
 - θ_2 = °C
 - θ_3 = °C
 - θ_4 = °C
6. Time for which water is collected (t) = 5 min = s.
7. Mass of water = m = gm = kg.
8. Specific heat of water = s = 1 kcal /kg°C (Given)

Calculations

$$K = \frac{m s (\theta_3 - \theta_4) d}{(\theta_1 - \theta_2) t}$$

K=.....kcal/ m °CS.

XII Results

Coefficient of thermal conductivity (K) of given material of rod K.....kcal/ m °Cs (MKS unit)

.....
.....
.....

XIII Interpretation of results

.....
.....
.....

XIV Conclusions and Recommendations

.....
.....
.....

XV Practical Related Questions

Note: Below given are few sample questions for reference. Teachers must design more such questions so as to ensure the achievement of identified CO.

1. Give reasons for covering copper rod by insulating material.
2. Under steady state the temperature of a body -
 - a) Increases with time
 - b) Decreases with time
 - c) Does not change with time and it remain same at all points of the body.
3. Give reasons for the temperatures 01, 02, 03 and 04 remains steady even if heating of rod is continued?
4. State the effect of heat conducted if area of rod is doubled?
5. Is this method is suitable for bad conductor? Give reasons.

[Space to Write Answers]

.....
.....
.....
.....
.....
.....
.....
.....
.....

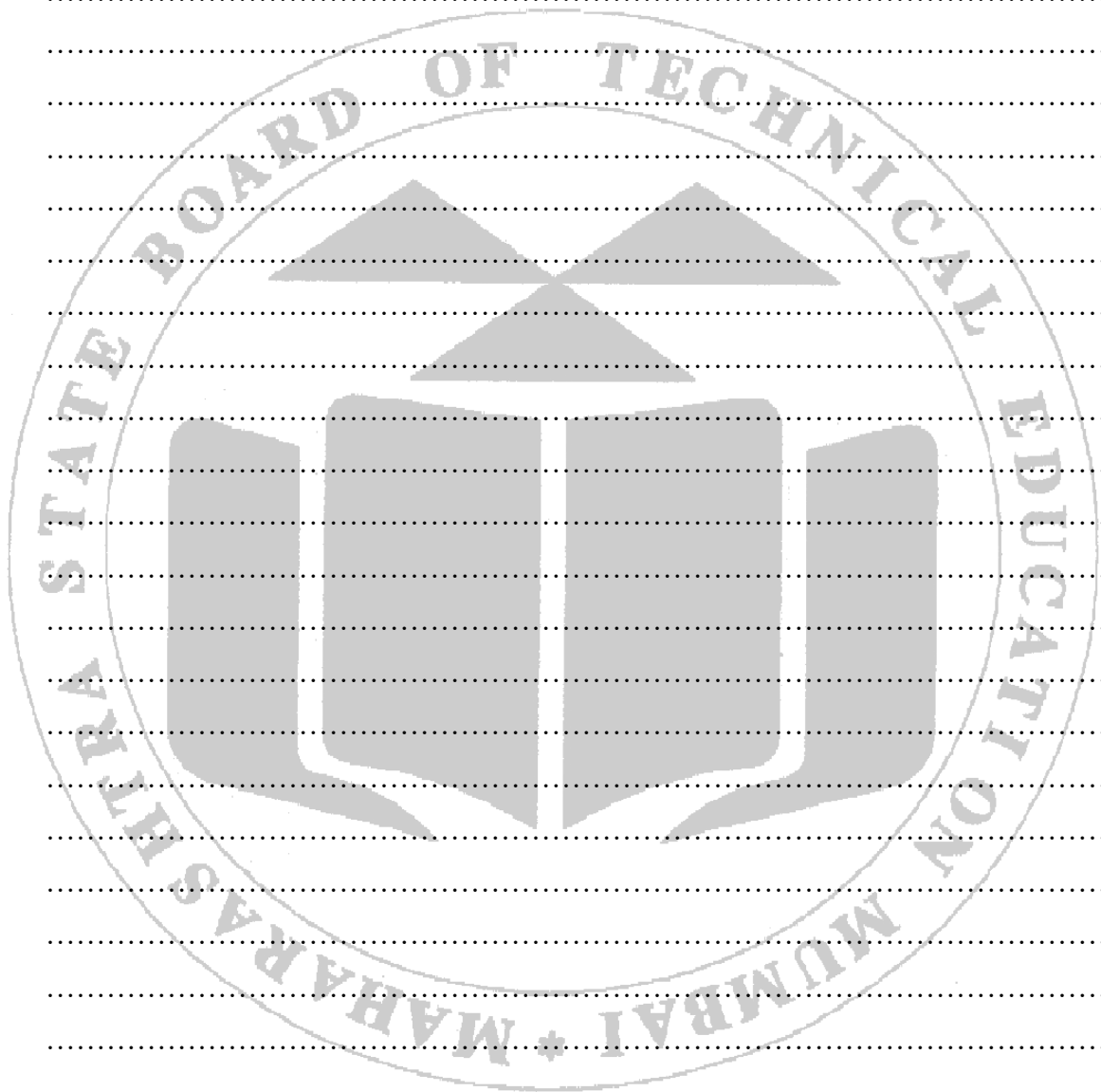

XVI References / Suggestions for further Readings

1. <https://youtu.be/dTGVvZ-UeCw?si=YqWLTlzDwm6f4f19h>
2. <https://youtu.be/qKhhrqhPfY>

XVII Assessment Scheme

Performance indicators		Weightage
Process related: 15 Marks		60%
1.	Selection of the instrument	10
2.	Arrangement of the instrument	10
3.	Connection of circuit diagram	10
4.	Handling of instruments	10
5.	Proper measurement	10
6.	Calculation of parameters concerned	10
Product related: 10 Marks		40%
1.	Accuracy of measurement	10
2.	Interpretation of result	10
3.	Conclusions & Recommendations	10
4.	Practical related questions	10

List of Student Team Members.

1.
2.
3.
4.

Marks Obtained			Dated Signature of Faculty
Process Related (15)	Product Related (10)	Total (25)	

Practical No.14: Determination of the refractive index of glass slab

I Practical Significance

Optical fibers has numbers of industrial and house hold applications, such as guiding medium for sending communication signals, fiber optic sensor for leveling of bridges, pressure sensor, stress sensor, Endoscopes and decorative purposes. Optical fiber works on the principle of total internal reflection (TIR). Mirage is an optical illusion, is also an illustration of TIR. In this lab experience student will analyze the phenomenon of TIR and determine the refractive index of glass by measuring the critical angle.

II Industry/ Employer Expected Outcome

Apply principles of physics and chemistry to solve broad based relevant engineering Problems.

III Course Level Learning Outcome

Apply basic principles of thermometry and fibre optics to solve engineering problems

IV Laboratory Learning Outcome(s)

Determine the refractive index of glass slab using TIR phenomenon.

V Relevant Affective domain related Outcomes

Practice good housekeeping.

VI Relevant Theoretical Background

Refractive index: It is a measure of bending of light while entering the medium. It is a dimensionless quantity. It is denoted as " μ ". *Snell's law* is defined as "The ratio of the sine of the angle of incidence to the sine of the angle of refraction is a constant, for the light of a given colour and for the given pair of media".

$$\mu = \frac{\sin i}{\sin r}$$

Critical angle: The critical angle of incidence is defined as that angle of incidence from denser medium for which the angle of refraction in rarer medium is 90° .

Total internal reflection: When a ray of light passes from a denser to a rarer medium, some part of it gets refracted into the rarer medium such that it bends away from the normal. Some part of it gets reflected back into the denser medium. The light reflected back into the denser medium is said to be internally reflected. In case of refraction from a denser to a rarer medium, the angle of refraction 'r' is greater than the angle of incidence 'i'. If the angle of incidence of the light ray is gradually increased, then at a certain angle of incidence, the angle of refraction in the rarer medium becomes 90° .

The refracted light grazes the interface of the two media. This angle of

incidence in the denser medium is called the critical angle, C, for the pair of media under consideration. When angle of incidence $i = C$, angle of refraction $r = 90^\circ$. The refractive index of the denser medium with respect to the rarer medium is given by,

$$\mu = \frac{1}{\sin C}$$

For total internal reflection, the conditions that must be satisfied are:

- Light must pass from a denser medium to a rarer medium.
- The angle of incidence in the denser medium must be greater than the critical angle for that pair of media.

VII Experimental set up / Work Situation.

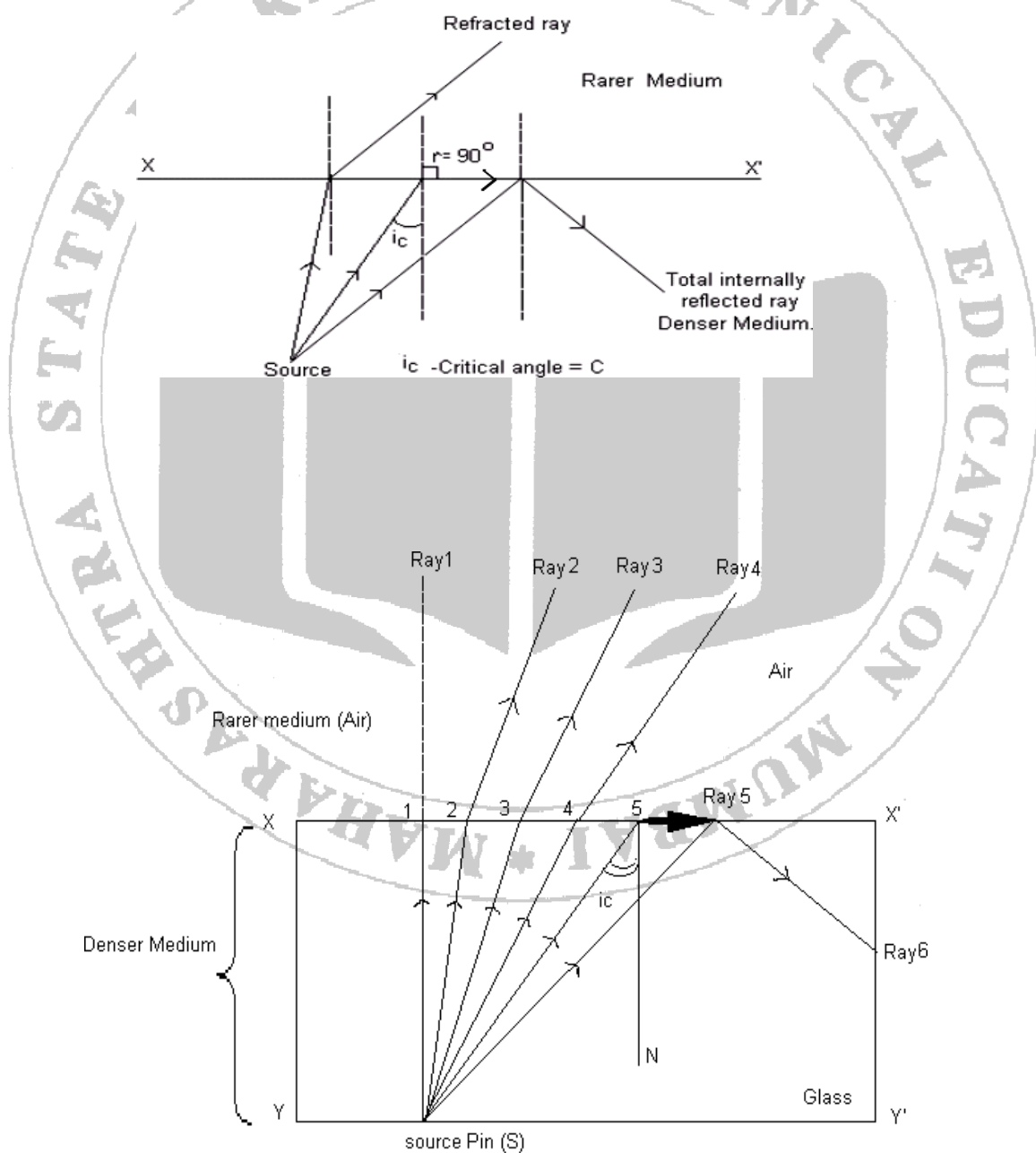

VIII Resources required

Sr. No.	Name of Instrument	Specifications	Quantity
1	Standard glass slab	Variable size, Different thickness	01
2	Drawing paper	A 4 size	01
3	Drawing pins		01
4	Drawing board	Base wood	01
5	Protractor, scale, HB/B pencil		01

IX Precautions

- a) Make sure that there is adequate ventilation (Sufficient Light).
- b) Clean drawing board before beginning work.

X Procedure

1. Place A4 size drawing paper on a drawing board properly.
2. Fix the paper using drawing pins .
3. Take the glass slab.
4. Clean glass slab with a white cotton cloth.
5. Place glass slab at the center of the drawing paper.
6. Mark the position outline with pencil, label it as XX' and YY' as given in Fig. 02
7. Place a pin near left comer 'Y' as source pin S.
8. Look at the source pin from other side through glass slab.
9. Locate point 1 on XX', with the help of another pin.
10. Mark point 2, 3 and 4 on plane XX' till refraction is observed.
11. Now select point number 5 such that the source gets just disappeared.
12. Join source point and 5 with straight line after removing glass slab.
13. Draw normal (N) to plane XX' through point 5.
14. Locate point 6 as shown in Fig.02.
15. Measure the critical angle of incidence $i_c = C$.
16. Calculate refractive index of material of glass slab.

XI Observations and Calculations

- a) Material of slab
- b) Critical angle of incidence $= i_c = C =$

Calculations

Refractive index of material of prism (μ)

$$\mu = \frac{1}{\sin C}$$

$\mu =$

XII Results

1. Critical angle of incidence for glass is
2. Refractive index of glass slab is

XIII Interpretation of results

.....
.....
.....

XIV Conclusions and Recommendations

.....
.....
.....

XV Practical Related Questions

Note: Below given are few sample questions for reference. Teachers must design more such questions so as to ensure the achievement of identified CO.

1. State the Snell's law.
2. Define Critical angle.
3. Write the condition of TIR
4. If the angle of incidence is 35 degree & angle of refraction is 40 degree. Find the refractive index.
5. Which among the following is the cause of the twinkling of stars?
(a) Bursting of light from the stars periodically (b) Variation of refractive index in the atmosphere (c) Incomplete absorption of light in the atmosphere (d) Interference of sunlight with the starlight

[Space to Write Answers]

.....
.....
.....
.....
.....
.....
.....
.....

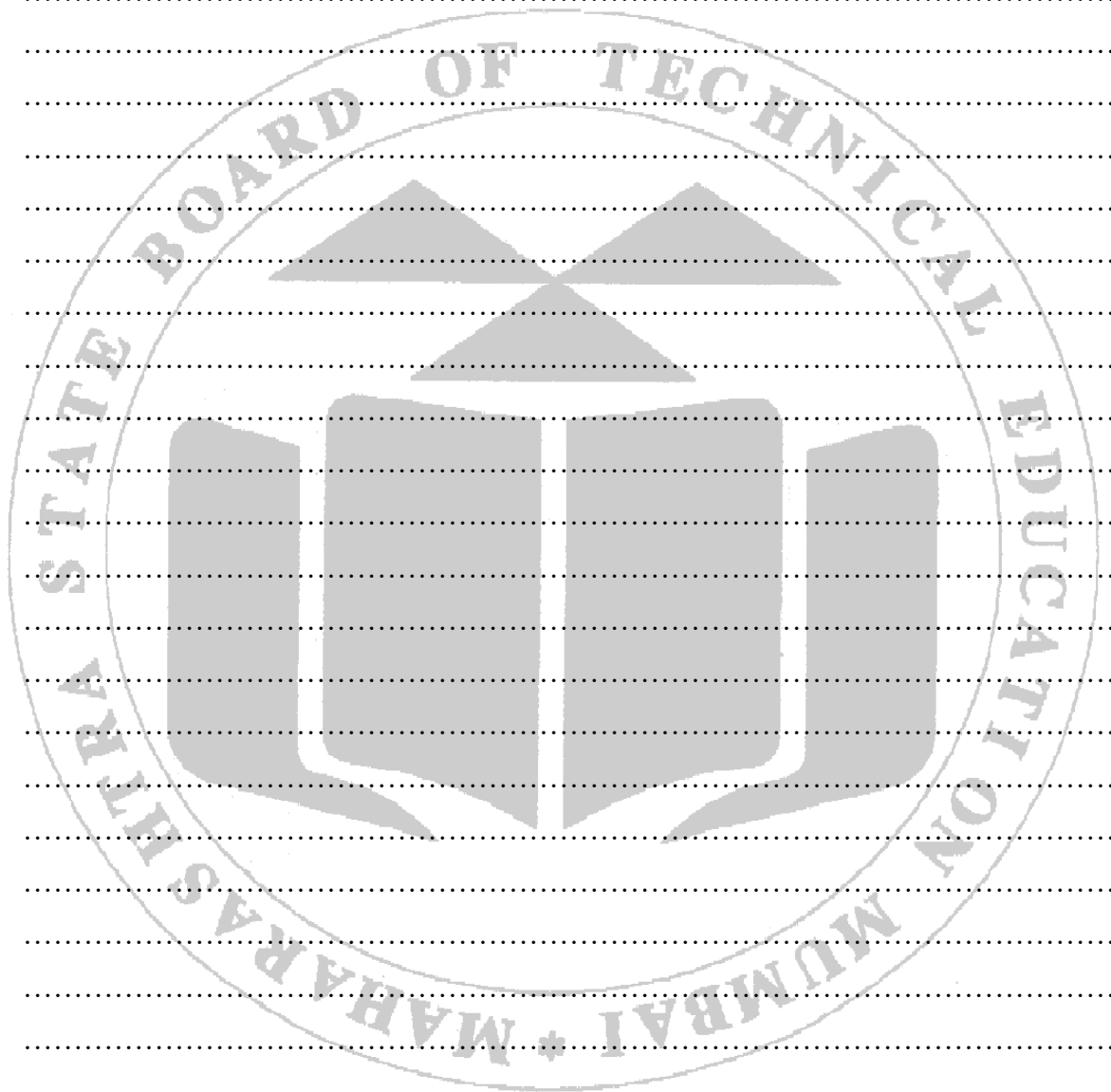

XVI References / Suggestions for further Readings

- <https://youtu.be/DQh9NpOPdwk?si=XpBCY9623WeV0MJp>
- <https://www.youtube.com/watch?v=oMGTnu2K11o>
- <https://www.youtube.com/watch?v=TH6LN4ZOQCM>

XVII Assessment Scheme

Performance indicators		Weightage
Process related: 15 Marks		60%
1.	Experimental set-up	10
2.	Handling of apparatus	20
3.	Correctness of reading	10
4.	Measurement of angles	20
Product related: 10 Marks		40%
1.	Timely submission and neatness	10
2.	Interpretation of result	10
3.	Conclusions & Recommendations	10
4.	Practical related questions	10

List of Student Team Members.

-
-
-
-

Marks Obtained			Dated Signature of Faculty
Process Related (15)	Product Related (10)	Total (25)	

Practical No.15: Determination of the Numerical Aperture (NA) of a given step index optical fiber.

I Practical Significance

In optics, the numerical aperture (NA) of an optical system is a dimensionless number that characterizes the range of angles over which the system can accept or emit light. By incorporating index of refraction in its definition, NA has the property that it is constant for a beam as it goes from one material to another, provided there is no refractive power at the interface. The exact definition of the term varies slightly between different areas of optics. Numerical aperture is commonly used in microscopy to describe the acceptance cone of an objective (and hence its light-gathering ability and resolution), and in fiber optics, in which it describes the range of angles within which light that is incident on the fiber will be transmitted along it.

II Industry/ Employer Expected Outcome

Apply principles of physics and chemistry to solve broad based relevant engineering problems.

III Course Level Learning Outcome

Determine the Numerical Aperture (NA) of a given step index optical fiber.

IV Laboratory Learning Outcome(s)

Apply basic principles of thermometry and fibre optics to solve engineering problems.

V Relevant Affective domain related Outcomes

- a) Handle the apparatus carefully.
- b) Practice good housekeeping.

VI Relevant Theoretical Background

Optical fibers are fine transparent glass or plastic fibers which can propagate light. They work under the principle of total internal reflection from diametrically opposite walls. In this way light can be taken anywhere because fibers have enough flexibility. This property makes them suitable for data communication, design of fine endoscopes, micro sized microscopes etc. An optic fiber consists of a core that is surrounded by a cladding which are normally made of silica glass or plastic. The core transmits an optical signal while the cladding guides the light within the core. Since light is guided through the fiber it is sometimes called an optical wave guide. The basic construction of an optic fiber is shown in figure (1). In order to understand the propagation of light through an optical fibre, consider the figure (2). Consider a light ray (i) entering the core at a point A, travelling through the core until it reaches the core cladding boundary at point B. As long as the light ray intersects the core-cladding boundary at a small angles, the ray will be reflected back in to the core to travel on to point C where the process of reflection is repeated .ie., total internal reflection takes place. Total internal reflection occurs only when the angle of incidence is greater than the critical angle. If a ray enters an optic fiber at a steep angle(ii), when this ray intersects the core-

cladding boundary, the angle of intersection is too large.

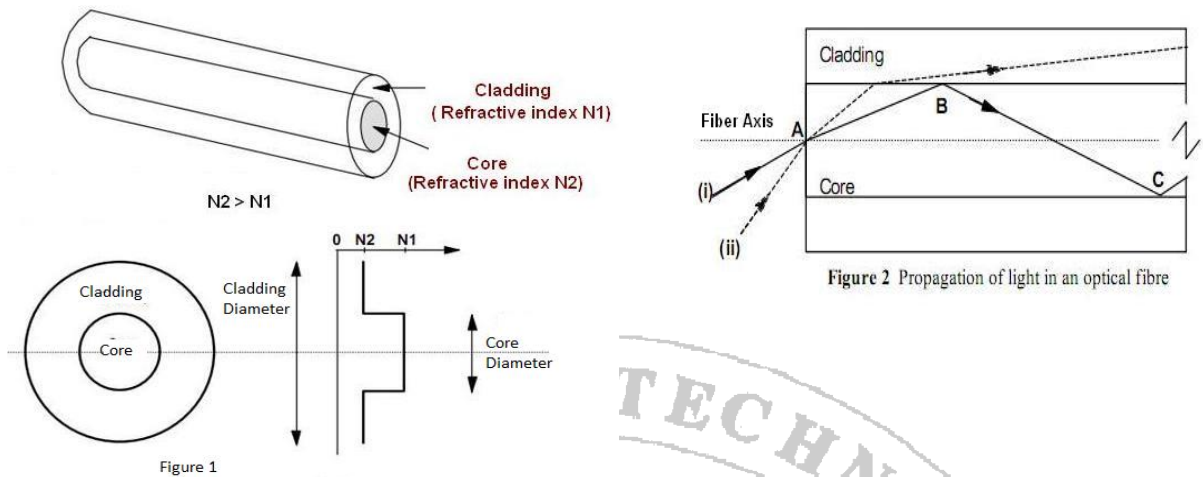

So, reflection back in to the core does not take place and the light ray is lost in the cladding. This means that to be guided through an optic fibre, a light ray must enter the core with an angle less than a particular angle called the acceptance angle of the fibre. A ray which enters the fiber with an angle greater than the acceptance angle will be lost in the cladding.

Consider an optical fibre having a core of refractive index n_1 and cladding of refractive index n_2 . Let the incident light makes an angle i with the core axis as shown in figure (3). Then the light gets refracted at an angle θ and fall on the core-cladding interface at an angle where,

$$\theta' = (90 - \theta) \text{ ----- (1)}$$

By Snell's law at the point of entrance of light in to the optical fiber we get,

$$n_0 \sin i = n_1 \sin \theta \text{ ----- (2)}$$

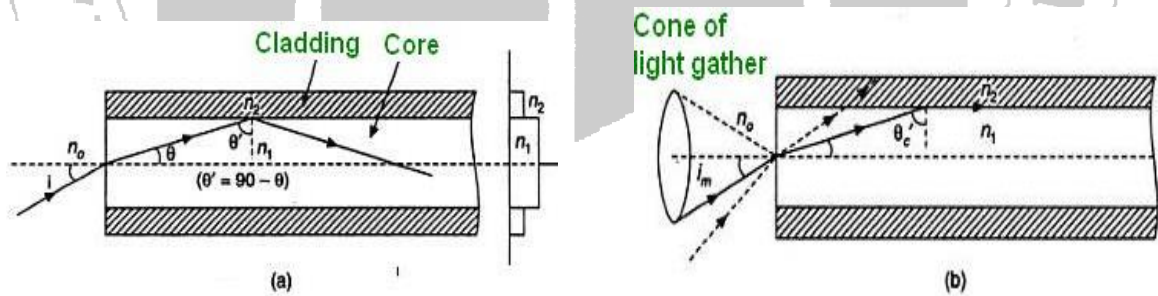

Figure 3

Where n_0 is refractive index of medium outside the fiber. For air $n_0 = 1$.

When light travels from core to cladding it moves from denser to rarer medium and so it may be totally reflected back to the core medium if θ' exceeds the critical angle θ'_c . The critical angle is that angle of incidence in denser medium (n_1) for which angle of refraction become 90° . Using Snell's laws at core cladding interface,

$$n_1 \sin \theta'_c = n_2 \sin 90 \quad \text{Or}$$

$$\sin \theta'_c = \frac{n_2}{n_1} \text{ ----- (3)}$$

Therefore, for light to be propagated within the core of optical fiber as guided wave, the angle of incidence at core-cladding interface should be greater than θ'_c . As i increases, θ increases and so θ' decreases. Therefore, there is maximum value of angle of incidence beyond which, it does not propagate rather it is refracted in to cladding medium (fig: 3(b)). This maximum value of i say i_m is called maximum angle of acceptance and $n_0 \sin i_m$ is termed as the numerical aperture (NA).

From equation (2),

$$NA = n_0 \sin i_m = n_1 \sin \theta$$

$$= n_1 \sin(90 - \theta_c)$$

$$\text{Or } NA = n_1 \cos \theta'_c$$

$$= n_1 \sqrt{1 - \sin^2 \theta'_c}$$

From equation (2) $\sin \theta'_c = \frac{n_2}{n_1}$

Therefore, $NA = n_1 \sqrt{1 - \frac{n_2^2}{n_1^2}}$

$$NA = \sqrt{n_1^2 - n_2^2}$$

VII Experimental Set up.

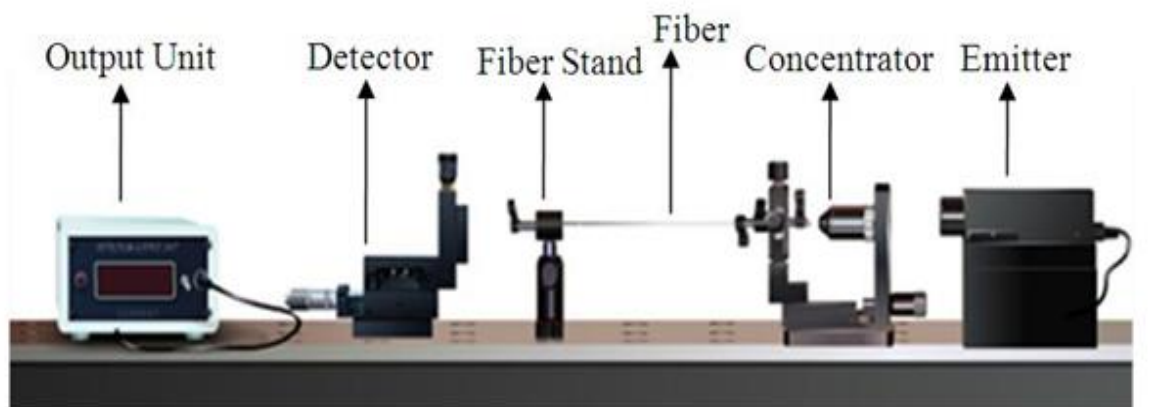

VIII Resources required

Sr. No.	Name of the equipment	Specification	Quantity
1	Laser light		1
2	Fibre optic cable		1
3	Microscope objective		1
4	Fiber chunks		1
5	Screen		1
6	Optical mount & post holder		1
7	Optical bench/ breadboard		1
8	Optical rollers		1

IX Precautions

1. Handle the equipment carefully.
2. Do not obstruct the path of the LASER beam

X Procedure

1. On optical bench arrange the apparatus in a proper sequence
2. Arrange the laser light at one end of the board.
3. Adjust the microscope in front of the laser light.
4. Optical mount and fiber chunks arrange in front of the microscope.
5. Adjust the fibre optical cable with both the stands.
6. When laser light passing through the microscope.
7. Adjust the microscope and monochromatic light is enters in the fibre optical cable.
8. When light passing through the fibre optical cable it will falls on the screen.
9. Adjust the distance of the screen, so we get the diversions of the beam on the screen.
 - a. Plot graph of spot size (r) vs distance between source and screen (d). Find slope of the graph.

XI Observations and Calculations

Sr.No.	Distance, (d) cm	Radius, (r) cm	NA = $\frac{r}{\sqrt{r^2 + d^2}}$	Average NA
1				
2				
3				
4				
5				

Calculations

.....
.....
.....
.....
.....
.....

XII Results

XIII Interpretation of results

XIV Conclusions and Recommendations

XV Practical Related Questions

Note: Below given are few sample questions for reference. Teachers must design more such questions so as to ensure the achievement of identified CO.

1. Define Numerical aperture.
2. What are three layers in optical fiber?
3. Optical fiber depends on which phenomenon?
4. If the refractive index of core is 1.55 and refractive index of cladding is 1.33, Calculate Numerical aperture.
5. What is the significance of NA?

[Space to Write Answers]

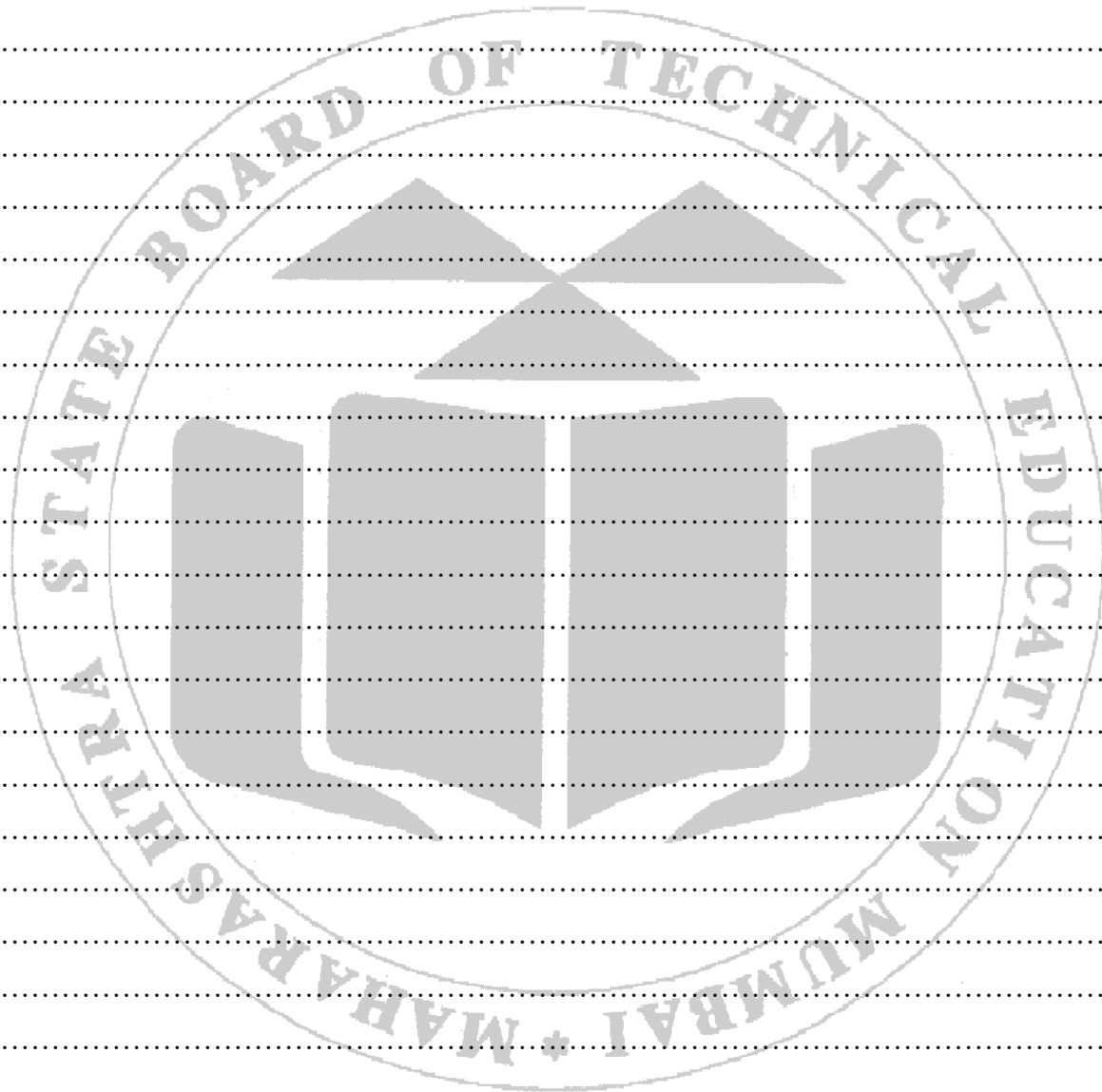

XVI References / Suggestions for further Readings

1. <https://vlab.amrita.edu/?sub=1&brch=189&sim=343&cnt=4>
2. <https://youtu.be/YUtsYkToTYI>

XVII Assessment Scheme

Performance indicators		Weightage
Process related: 15 Marks		60%
1.	Experimental set-up	10
2.	Handling of apparatus	20
3.	Correctness of reading	10
4.	Measurement of angles	20
Product related: 10 Marks		40%
1.	Timely submission and neatness	10
2.	Interpretation of result	10
3.	Conclusions & Recommendations	10
4.	Practical related questions	10

List of Student Team Members.

1.
2.
3.
4.

Marks Obtained			Dated Signature of Faculty
Process Related (15)	Product Related (10)	Total (25)	